

SECTION VI: AGREEMENT

1 **AGREEMENT NO. C-9-1787**

2 **BETWEEN**

3 **ORANGE COUNTY TRANSPORTATION AUTHORITY**

4 **AND**

5 _____

6 **THIS AGREEMENT** is effective this _____ day of _____, 202__
7 ("Effective Date"), by and between the Orange County Transportation Authority, 550 South Main Street,
8 P.O. Box 14184, Orange, CA 92863-1584, a public corporation of the State of California (hereinafter
9 referred to as "AUTHORITY"), and , , , , (hereinafter referred to as "CONTRACTOR").

10 **WITNESSETH:**

11 **WHEREAS**, AUTHORITY has determined that it requires the Metrolink Train Stations Platform
12 Detectable Tiles Replacement and Painted Guidelines Restriping Project; and

13 **WHEREAS**, said work cannot be performed by the regular employees of AUTHORITY; and

14 **WHEREAS**, CONTRACTOR has represented that it has the requisite personnel, experience,
15 material, and equipment and is otherwise qualified to perform such services; and

16 **WHEREAS**, CONTRACTOR wishes to perform these services; and

17 **WHEREAS**, AUTHORITY's Board of Directors authorized this Agreement on _____.

18 **NOW, THEREFORE**, it is mutually understood and agreed by AUTHORITY and CONTRACTOR
19 as follows:

20 **ARTICLE 1. COMPLETE AGREEMENT**

21 A. This Agreement, including all exhibits and other documents incorporated herein and made
22 applicable by reference, constitutes the complete and exclusive statement of the terms and conditions of
23 the Agreement between AUTHORITY and CONTRACTOR and it supersedes all prior representations,
24 understandings and communications. The invalidity in whole or in part of any term or condition of this
25 Agreement shall not affect the validity of other terms or conditions.

26 /

1 B. AUTHORITY's failure to insist in any one or more instances upon the performance of any
2 terms or conditions of this Agreement shall not be construed as a waiver or relinquishment of
3 AUTHORITY's right to such performance by CONTRACTOR or to future performance of such terms or
4 conditions and CONTRACTOR's obligation in respect thereto shall continue in full force and effect.
5 CONTRACTOR shall be responsible for having taken steps reasonably necessary to ascertain the nature
6 and location of the work, and the general and local conditions, which can affect the work or the cost
7 thereof. Any failure by CONTRACTOR to do so will not relieve it from responsibility for successfully
8 performing the work without additional expense to AUTHORITY.

9 C. AUTHORITY assumes no responsibility for any understanding or representations concerning
10 conditions made by any of its officers, employees or agents prior to the execution of this Agreement,
11 unless such understanding or representations by AUTHORITY are expressly stated in this Agreement.

12 D. Time shall be of the essence hereunder; but CONTRACTOR shall perform work hereunder
13 only to the minimum extent consistent with requirements herein.

14 E. Changes to any portion of this Agreement shall not be binding upon AUTHORITY except
15 when specifically confirmed in writing by an authorized representative of AUTHORITY and issued in
16 accordance with the provisions of this Agreement.

17 **ARTICLE 2. AUTHORITY DESIGNEE**

18 The Chief Executive Officer of AUTHORITY, or designee, shall have the authority to act for and
19 exercise any of the rights of AUTHORITY as set forth in this Agreement.

20 **ARTICLE 3. SCOPE OF WORK**

21 CONTRACTOR shall provide all labor, equipment, materials and facilities necessary for all work
22 related to Metrolink Train Stations Platform Detectable Tiles Replacement and Painted Guidelines
23 Restriping Project at AUTHORITY's ENTER LOCATIONS in strict compliance with all the requirements
24 specified herein and in:

25 Attachment A, entitled "Disadvantaged Business Enterprise (DBE) Contract Provisions for U.S.
26 DOT-assisted Contracts";

1 Attachment A-1, entitled "DBE Participation Commitment Form"

2 Exhibit A, entitled "General Provisions";

3 Addendum No's ____;

4 Exhibit B, entitled "Scope of Work / Project Specifications";

5 Exhibit C, not used";

6 Exhibit D, entitled "List of Subcontractors";

7 Exhibit E, entitled "Performance Bond";

8 Exhibit F, entitled "Payment Bond";

9 Exhibit G, entitled "Guaranty";

10 Exhibit H, entitled "Contract Change Order"; and

11 Exhibit I, entitled "Level III Safety Specifications";

12 all of which documents are attached to and, by this reference, incorporated in and made a part of this
13 Agreement. By this reference, also incorporated in and made a part of this Agreement are all applicable
14 provisions of the IFB and all representations made by CONTRACTOR in its original bid to AUTHORITY,
15 including, but not limited to, CONTRACTOR's certifications relative to Workers' Compensation Insurance,
16 and compliance with Section 7028.15 of the State of California Business and Professions Code.

17 **ARTICLE 4. DELIVERY / RECOVERY SCHEDULE**

18 A. CONTRACTOR shall fully complete the herein above described work within (180) calendar
19 days from the effective date of written Notice to Proceed (NTP) issued by AUTHORITY. CONTRACTOR
20 shall give AUTHORITY not less than seventy-two (72) hours advance notice of the start of any work.
21 Within five (5) calendar days after said notice, CONTRACTOR shall provide any construction schedules
22 as may be requested by AUTHORITY.

23 B. If at any time, the critical path schedule reflects -30 or a greater negative number of days of
24 total float, then CONTRACTOR, within ten (10) calendar days after CONTRACTOR first becomes aware
25 of such schedule delay, shall prepare and submit to AUTHORITY for review and approval a Recovery
26 Schedule demonstrating CONTRACTOR's proposed plan to regain lost schedule progress and to

1 achieve the original contractual milestones in accordance with the Agreement. AUTHORITY shall notify
2 CONTRACTOR within ten (10) calendar days after receipt of each such Recovery Schedule whether the
3 schedule is deemed accepted or rejected. Within five (5) calendar days after AUTHORITY's rejection of
4 the schedule, CONTRACTOR will resubmit a revised Recovery Schedule incorporating AUTHORITY's
5 comments. When AUTHORITY accepts CONTRACTOR's Recovery Schedule, CONTRACTOR shall,
6 within five (5) calendar days after AUTHORITY's acceptance, incorporate and fully include such schedule
7 into the Project Schedule and deliver it to AUTHORITY.

8 C. All costs incurred by CONTRACTOR in preparing, implementing and achieving the Recovery
9 Schedule shall be borne by CONTRACTOR and shall not result in a change to the contract price.

10 D. In the event that CONTRACTOR fails to provide an acceptable Recovery Schedule within
11 thirty (30) calendar days of CONTRACTOR's receipt of a notice to do so, CONTRACTOR shall have no
12 right to receive progress payments until CONTRACTOR has prepared and AUTHORITY has approved
13 such Recovery Schedule.

14 **ARTICLE 5. START OF WORK**

15 CONTRACTOR shall incur no costs, and shall not perform or furnish any work, services, materials
16 or equipment under this Agreement, unless and until a written Notice to Proceed has been given to
17 CONTRACTOR by AUTHORITY. Conditions precedent to AUTHORITY issuing said Notice to Proceed
18 are CONTRACTOR furnishing the Exhibit E "Performance Bond", Exhibit F "Payment Bond", Exhibit G
19 "Guaranty", and certificates of insurance as set forth in Article 11 hereunder. CONTRACTOR shall furnish
20 said documents within ten (10) calendar days after notification of contract award from AUTHORITY.
21 Upon receipt of acceptable bonds, guaranty, and insurance certificates, AUTHORITY will within ten (10)
22 working days thereafter, issue the written Notice to Proceed.

23 **ARTICLE 6. PAYMENT**

24 A. For CONTRACTOR's full and complete performance of its obligations under this Agreement,
25 and subject to the maximum cumulative payment obligation provision set forth in Article 8, AUTHORITY
26 shall pay CONTRACTOR the firm fixed sum of Dollars (\$.00).

1 B. Progress payments and the final payment will be made by AUTHORITY to CONTRACTOR
2 in accordance with the terms as set forth in Exhibit A, "General Provisions", under the "Progress
3 Payments" and "Final Payment and Claims" sections therein. The acceptance by CONTRACTOR of
4 AUTHORITY's final payment hereunder shall constitute a waiver of all claims against AUTHORITY under
5 or arising out of this herein Agreement, as such may from time to time be amended.

6 C. Failure by AUTHORITY to pay amount in dispute shall not alleviate, diminish or modify in any
7 respect the CONTRACTOR's obligation to achieve final acceptance of and all work in accordance with
8 the contract documents, and CONTRACTOR shall not cease or slow down its performance under this
9 Agreement on account of any such amount in dispute. CONTRACTOR shall proceed as directed by
10 AUTHORITY pending resolution of dispute. Upon resolution of dispute, each party shall promptly pay
11 any amount owing.

12 **ARTICLE 7. PROMPT PAYMENT CLAUSE**

13 A. AUTHORITY has adopted a prompt payment provision on all U.S. DOT-assisted contracts to
14 facilitate timely payment to all subcontractors in accordance with regulatory mandates. Pursuant to
15 49 CFR Part 26.29, AUTHORITY will include the following clause in each U.S. DOT-assisted contract:

16 B. "CONTRACTOR agrees to pay each subcontractor under this Contract for satisfactory
17 performance of its contract no later than seven (7) calendar days from the receipt of each payment
18 CONTRACTOR receives from AUTHORITY. CONTRACTOR agrees further to return retainage
19 payments to each subcontractor within thirty (30) calendar days after receiving payment for work
20 satisfactorily completed and accepted including incremental acceptances of portions of the Agreement
21 work by AUTHORITY. Any delay or postponement of payment from the above referenced time frame
22 may take place only for good cause and with AUTHORITY's prior written approval." CONTRACTOR shall
23 incorporate this clause verbatim, set forth above, in all subcontract, broker, dealer, vendor, supplier,
24 purchase order or other source agreements issued to both DBE and non-DBE firms.

25 C. Any violation of the provisions listed above shall subject the violating CONTRACTOR to the
26 penalties, sanctions, and other remedies specified in Section 7108.5 of the California Business and

1 Professions Code. This requirement shall not be construed to limit or impair any contractual,
2 administrative or judicial remedies otherwise available to CONTRACTOR or subcontractor in the event
3 of a dispute involving late payment or nonpayment by CONTRACTOR; deficient subcontractor
4 performance and/or noncompliance by a subcontractor.

5 D. Failure to comply with this provision without prior approval from AUTHORITY will constitute
6 noncompliance, which may result in the application of appropriate administrative sanctions, including, but
7 not limited to, a penalty of two percent (2%) of the invoice amount due per month, for every month that
8 full payment is not made.

9 **ARTICLE 8. MAXIMUM OBLIGATION**

10 Notwithstanding any provisions of this Agreement to the contrary, AUTHORITY and
11 CONTRACTOR mutually agree that AUTHORITY's maximum cumulative payment obligation hereunder
12 (including obligation for CONTRACTOR 's profit), shall be Dollars (\$.00), which shall include all amounts
13 payable to CONTRACTOR for its subcontracts, leases, materials and costs arising from, or due to
14 termination of, this Agreement.

15 **ARTICLE 9. NOTICES**

16 All notices hereunder and communications regarding the interpretation of the terms of this
17 Agreement, or changes thereto, shall be effected by delivery of said notices in person or by depositing
18 said notices in the U.S. mail, registered or certified mail, returned receipt requested, postage prepaid and
19 addressed as follows:

20 /

21 /

22 /

23 /

24 /

25 /

26 /

1 To CONTRACTOR:

To AUTHORITY:

2 Orange County Transportation Authority

3 550 South Main Street

4 P.O. Box 14184

5 Orange, CA 92863-1584

6 ATTENTION:

ATTENTION: Sonja Gettel

7 Title:

Title: Senior Contract Administrator

8 Tel:

Tel: (714) 560-5562

9 E-Mail:

E-Mail: sgettel@octa.net

10 ATTENTION: Jason Lee

11 Tel: (714) 560-5833

12 E-Mail: jlee1@octa.net

13 AUTHORITY will provide timely notification to CONTRACTOR of the receipt of any third-party claim
14 relating to the Agreement, and CONTRACTOR agrees to timely reimburse AUTHORITY for its
15 reasonable costs incurred in providing such notice in accordance with Public Contract Code
16 Section 9201.

17 **ARTICLE 10. INDEPENDENT CONTRACTOR**

18 A. CONTRACTOR's relationship to AUTHORITY in the performance of this Agreement is that of
19 an independent contractor. CONTRACTOR's personnel performing work under this Agreement shall at
20 all times be under CONTRACTOR's exclusive direction and control and shall be employees of
21 CONTRACTOR and not employees of AUTHORITY. CONTRACTOR shall pay all wages, salaries and
22 other amounts due its employees in connection with this Agreement and shall be responsible for all
23 reports and obligations respecting them, such as social security, income tax withholding, unemployment
24 compensation, workers' compensation and similar matters.

25 B. Should CONTRACTOR's personnel or a state or federal agency allege claims against
26 AUTHORITY involving the status of AUTHORITY as employer, joint or otherwise, of said personnel, or

1 allegations involving any other independent contractor misclassification issues, CONTRACTOR shall
2 defend and indemnify AUTHORITY in relation to any allegations made.

3 **ARTICLE 11. INSURANCE**

4 A. CONTRACTOR shall procure and continuously maintain in full force and effect through
5 contract completion, insurance coverages specified herein. Coverages shall not be subject to self-
6 insurance provisions. CONTRACTOR shall provide the following insurance coverage:

7 1. Commercial General Liability, to include Products/Completed Operations,
8 Independent Contractors', Contractual Liability, and Personal Injury with a minimum limit of \$2,000,000
9 per occurrence and \$4,000,000 general aggregate.

10 2. Automobile Liability to include owned, hired and non-owned autos with a combined
11 single limit of \$1,000,000 each accident;

12 3. Workers' Compensation with limits as required by the State of California, including
13 waiver of subrogation, in favor of AUTHORITY, its officers, directors, employees and agents.

14 4. Employers' Liability with minimum limits of \$1,000,000.

15 5. RR Protective Liability with minimum limits of \$2,000,000.00 with a \$6,000,000.00
16 aggregate per claim.

17 6. Railroad Protective Liability Insurance – The policy shall have limits of liability of not
18 less than \$2 million per occurrence, combined single limit, for coverage and for losses arising out of injury
19 to or death of all persons and for physical loss or damage to or destruction of Property, including the loss
20 of use thereof. A \$6 million annual aggregate shall apply. If coverage is provided on the London claims-
21 made form, the following provisions shall apply:

22 7. The limits of liability shall be not less than \$3 million per occurrence, combined single
23 limit. A \$9 million aggregate may apply.

24 8. Declarations item 6, extended claims made date, shall allow an extended claims made
25 period no shorter than the length of the original policy period plus one year.

26 /

1 9. If equivalent or better, wording is not contained in the policy form, the following
2 endorsement must be included: It is agreed that "physical damage to Property" means direct and
3 accidental loss of or damage to rolling stock and their contents, mechanical construction equipment or
4 motive power equipment, railroad tracks, roadbed, catenaries, signals, bridges or building.

5 B. Proof of such coverage, in the form of an insurance company issued policy endorsement and
6 a broker-issued insurance certificate, must be received by AUTHORITY prior to commencement of any
7 work. Proof of insurance coverage must be received by AUTHORITY within ten (10) calendar days from
8 the effective date of this Agreement with AUTHORITY, its officers, directors, employees and agents, as
9 well as the cities of Buena Park, Fullerton, Orange, Santa Ana, Laguna Niguel and San Clemente, BNSF,
10 Amtrak, Union Pacific, and Southern California Regional Rail Authority (SCRRA) designated as additional
11 insured on the commercial general and automobile liability. Such insurance shall be primary and non-
12 contributive to any insurance or self-insurance maintained by the AUTHORITY. Furthermore,
13 AUTHORITY reserves the right to request certified copies of all related insurance policies.

14 C. Prior to commencement of any work hereof, CONTRACTOR shall furnish to AUTHORITY's
15 Contract Administrator broker-issued insurance certificate showing the required insurance coverages and
16 further providing that:

17 1. AUTHORITY, its officers, directors, employees and agents must be named as
18 additional insured on Commercial General Liability and Automobile Liability policy with respect to
19 performance hereunder; and

20 2. The coverage shall be primary and noncontributory as to any other insurance with
21 respect to performance hereunder; and

22 3. Thirty (30) days prior written notice of cancellation or material change be given to
23 AUTHORITY.

24 D. "Occurrence," as used herein, means any event or related exposure to conditions, which
25 result in bodily injury or property damage.

26 /

1 E. The Certificate of Insurance shall reference Agreement Number C-9-1787; and, the Contract
2 Administrator's Name, Sonja Gettel.

3 F. Upon AUTHORITY's request, certified, true and exact copies of each of the insurance policies
4 shall be provided to AUTHORITY.

5 G. AUTHORITY shall notify CONTRACTOR in writing of any changes in the requirements to
6 insurance required to be provided by CONTRACTOR. Except as set forth in this Article, any additional
7 cost from such change shall be paid by AUTHORITY and any reduction in cost shall reduce the
8 Agreement price pursuant to a change order.

9 H. CONTRACTOR shall also include in each subcontract the stipulation that subcontractors shall
10 maintain coverage in the amounts required as provided in this Agreement.

11 I. CONTRACTOR shall be required to immediately notify AUTHORITY of any modifications or
12 cancellation of any required insurance policies.

13 **ARTICLE 12. BONDS**

14 A. By submitting Exhibit E, entitled "Performance Bond", and Exhibit F, entitled "Payment Bond",
15 CONTRACTOR shall satisfy AUTHORITY's requirements that CONTRACTOR deposit with AUTHORITY
16 bonds with values in the sum of one hundred percent (100%) of this Agreement's price to cover
17 CONTRACTOR's failure to fully perform hereunder and CONTRACTOR's failure to pay its labor, material
18 or failure to comply with Article 39 of this Agreement, in performing hereunder. If the Agreement price is
19 increased in connection with a Change Order, AUTHORITY may, in its sole discretion, require a
20 corresponding increase in the amount of the Performance and Payment bonds or new bonds covering
21 the Change Order work.

22 B. Notwithstanding any other provision set forth in this Agreement, performance by a Surety or
23 Guarantor of any obligations of CONTRACTOR shall not relieve CONTRACTOR of any of its obligations
24 thereunder.

25 /

26 /

1 **ARTICLE 13. ORDER OF PRECEDENCE**

2 To the extent there are any conflicts or inconsistency arising between any provisions or
3 documents incorporated in this Agreement, the order of precedence for conflict resolution in descending
4 order shall be as follows: (1) the provisions of this Agreement, including its Exhibits; (2) the provisions of
5 IFB 9-1787 including all Addendums; (3) the bid submitted to AUTHORITY by CONTRACTOR in
6 response to said IFB; and (4) any other documents, cited herein or incorporated by reference.

7 **ARTICLE 14. CHANGES**

8 A. By written notice or order, AUTHORITY may, from time to time, order work suspension and/or
9 make any change in the general scope of this Agreement, including, but not limited to, changes in the
10 drawings, specifications, schedules (either deceleratory or acceleratory) or any other particular of the
11 specifications or provisions of this Agreement. If any such work suspension or change causes an
12 increase or decrease in the price or time required for performance, CONTRACTOR shall promptly notify
13 AUTHORITY thereof and assert its claim for adjustment within ten (10) calendar days after the change
14 or work suspension is ordered, and an equitable adjustment shall be negotiated. However, nothing in
15 this clause shall excuse CONTRACTOR from proceeding immediately with the Agreement as changed.
16 Changes will be made in accordance with the terms as set forth in Exhibit A, "General Provisions",
17 paragraph F, Extra Work and Changes, by written Change Order.

18 B. No claims by CONTRACTOR for equitable adjustment hereunder shall be allowed if asserted
19 after final payment under this Agreement.

20 C. Any work performed beyond the technical provisions specified in this Agreement, or any extra
21 work performed without AUTHORITY's written authority, will be considered unauthorized work and the
22 cost thereof will not be paid for. Upon order of AUTHORITY's Engineer or its designee, unauthorized
23 work shall be remedied, removed or replaced at CONTRACTOR's expense.

24 D. Any changes under this Article will be made using AUTHORITY's Contract Change Order
25 form, set forth in Exhibit H, "Contract Change Order".

26 /

1 E. Any changes which constitute a "Claim" as defined by Public Contract Code Section 9204
2 (hereinafter "Section 9204") will be processed in accordance with Section 9204 and Exhibit A, "General
3 Provisions."

4 **ARTICLE 15. MODIFICATION BID-PRICE BREAKDOWN**

5 CONTRACTOR, in connection with any bid it makes for a change order, shall furnish a price
6 breakdown, itemized as required by AUTHORITY. Unless otherwise directed, the price breakdown shall
7 be in sufficient detail to permit an analysis of all material, labor, equipment, subcontract and overhead
8 costs, as well as profit, and shall cover all work involved in the modification, whether such work was
9 deleted, added or changed. Any expense claimed by subcontractors shall be supported by a similar price
10 breakdown. In addition, if the bid includes a time extension, a justification therefore shall be furnished.
11 The bid, together with the price breakdown and time extension justification, shall be furnished by the date
12 specified by AUTHORITY.

13 **ARTICLE 16. DISPUTES**

14 A. Except as otherwise provided in this Agreement, when a dispute arises between
15 CONTRACTOR and AUTHORITY, the project managers shall meet to resolve the issue. If project
16 managers do not reach a resolution, the dispute will be decided by AUTHORITY's Director of Contracts
17 Administration and Materials Management (CAMM), who shall reduce the decision to writing and mail or
18 otherwise furnish a copy thereof to CONTRACTOR. The decision of the Director, CAMM, shall be the
19 final and conclusive administrative decision.

20 B. Pending final decision of a dispute hereunder, CONTRACTOR shall proceed diligently with
21 the performance of this Agreement and in accordance with the decision of AUTHORITY's Director,
22 CAMM. Nothing in this Agreement, however, shall be construed as making final the decision of any
23 AUTHORITY official or representative on a question of law, which questions shall be settled in
24 accordance with the laws of the State of California.

25 /

26 /

1 **ARTICLE 17. TERMINATION FOR CONVENIENCE**

2 A. AUTHORITY may terminate this Agreement for its convenience at any time in whole or in
3 part, by giving CONTRACTOR written notice thereof. AUTHORITY shall terminate by delivering to
4 CONTRACTOR a written Notice of Termination for Convenience specifying the extent of termination and
5 its effective date. Upon termination, AUTHORITY shall pay CONTRACTOR its allowable costs incurred
6 to date of that portion terminated. The rights, duties and obligations of the parties shall be construed in
7 accordance with the applicable provisions of the Code of Federal Regulations (CFR) Title 48, Chapter 1,
8 part 49, of the Federal Acquisition Regulation (FAR) and specific subparts and other provisions thereof
9 applicable to termination for convenience. If AUTHORITY sees fit to terminate this Agreement for
10 convenience, said notice shall be given to CONTRACTOR in accordance with the provisions of the FAR
11 referenced above and Article 9, herein. Upon receipt of said notification, CONTRACTOR shall
12 immediately proceed with all obligations, regardless of any delay in determining or adjusting any amounts
13 due under this Article, and agrees to comply with all applicable provisions of the FAR pertaining to
14 termination for convenience.

15 **ARTICLE 18. TERMINATION FOR DEFAULT-DAMAGES FOR DELAY-TIME EXTENSIONS**

16 A. If CONTRACTOR refuses or fails to prosecute the work, or any separable part thereof, with
17 such diligence as will ensure its completion within the time specified in this Agreement, or any extension
18 thereof, or fails to complete said work within such time, AUTHORITY may, by written notice to
19 CONTRACTOR that specifies the nature of the default, terminate CONTRACTOR's right to proceed with
20 the work or such part of the work as to which there has been delay. In such event, AUTHORITY may
21 take over the work and prosecute the same to completion, by Agreement or otherwise, and may take
22 possession of and utilize in completing the work such materials, appliances and plant as may be on the
23 site of the work and necessary therefore. Whether or not CONTRACTOR's right to proceed with the work
24 is terminated, CONTRACTOR and its sureties shall be liable for any damage to AUTHORITY resulting
25 from its refusal or failure to complete the work within the specified time.

26 /

1 B. If AUTHORITY so terminates CONTRACTOR's right to proceed, the resulting damage will
2 consist of such liquidated damages as set forth in the Article 38 in this Agreement entitled "Liquidated
3 Damages," until such reasonable time as may be required for final completion of the work together with
4 any increased costs occasioned AUTHORITY in completing the work. If AUTHORITY does not so
5 terminate CONTRACTOR's right to proceed, the resulting damage will consist of such liquidated
6 damages until the work is completed or accepted.

7 C. CONTRACTOR's right to proceed shall not be so terminated nor the CONTRACTOR charged
8 with resulting damage if:

9 1. The delay in completing the work arises from unforeseeable causes beyond the
10 control and without the fault or negligence of CONTRACTOR, including but not restricted to, acts of God,
11 acts of the public enemy, acts or omissions of AUTHORITY, acts of another CONTRACTOR in the
12 performance of an Agreement with AUTHORITY, fires, floods, epidemics, quarantine restrictions, freight
13 embargoes, unusually severe weather, or delays of subcontractors or suppliers arising from
14 unforeseeable causes beyond the control and without the fault or negligence of both CONTRACTOR and
15 such subcontractors or suppliers; and

16 2. CONTRACTOR, within ten (10) calendar days from the beginning of any such delay,
17 notifies AUTHORITY in writing of the causes of delay. AUTHORITY shall ascertain the facts and the
18 extent of the delay and extend the time for completing the work when, in its judgment, the findings of fact
19 justify such an extension, and its findings of fact shall be final and conclusive on the parties, subject only
20 to appeal as provided in the "Disputes" clause of this Agreement. Any such time extensions will not
21 become effective until approved by AUTHORITY's Engineer in writing. AUTHORITY's Engineer will
22 furnish CONTRACTOR a weekly statement showing the number of calendar days charged to the
23 Agreement for the preceding week, the number of calendar days of time extensions being considered or
24 approved, the number of calendar days originally specified for the completion of this Agreement and the
25 number of calendar days remaining to complete this Agreement, and the extended date for completion
26 thereof.

1 3. Should at any time extensions be included by AUTHORITY's Engineer on the Weekly
2 Statement of Contract Calendar Days, a change order covering the sum total of the time extensions will
3 be issued to CONTRACTOR at periodic intervals during the project.

4 D. If, after notice of termination of CONTRACTOR's right to proceed under the provisions of this
5 clause, it is determined for any reason that CONTRACTOR was not in default under the provisions of this
6 clause, or that the delay was excusable under the provisions of this clause, the rights and obligations of
7 the parties shall be the same as if the notice of termination had been issued pursuant to Article 17, entitled
8 "Termination for Convenience".

9 E. The rights and remedies of AUTHORITY provided in this clause are in addition to any other
10 rights and remedies provided by law or under this Agreement.

11 F. As used in paragraph C.1 of this Article, the term "subcontractors or suppliers," means
12 subcontractors or suppliers at any tier.

13 **ARTICLE 19. INDEMNIFICATION**

14 CONTRACTOR shall indemnify, defend, and hold harmless AUTHORITY, its officers, directors,
15 employees and agents from and against any and all claims (including attorneys' fees and reasonable
16 expenses for litigation or settlement) for any loss, costs, penalties, fines, damages, bodily injuries,
17 including death, damage to or loss of use of property, arising out of, resulting from, or in connection with
18 the performance of CONTRACTOR, its officers, directors, employees, agents, subcontractors or
19 suppliers under the Agreement. Notwithstanding the foregoing, such obligation to defend, hold harmless,
20 and indemnify AUTHORITY, its officers, directors, employees and agents shall not apply to such claims
21 or liabilities arising from the sole or active negligence or willful misconduct of AUTHORITY.

22 **ARTICLE 20. ASSIGNMENTS AND SUBCONTRACTS**

23 A. Neither this Agreement nor any interest herein nor claim hereunder may be assigned by
24 CONTRACTOR either voluntarily or by operation of law. CONTRACTOR shall not have the right to make
25 any substitutions of any subcontractor listed in Exhibit D, entitled "List of Subcontractors," except in
26 accordance with the provisions of the Subletting and Subcontractors Fair Practices Act, Public Contract

1 Code Section 4100 et seq. AUTHORITY's consent shall not be deemed to relieve CONTRACTOR of its
2 obligation to fully comply with the requirements of this Agreement.

3 B. CONTRACTOR shall be fully responsible to AUTHORITY for all acts and omissions of its own
4 employees, and of subcontractors and their employees. CONTRACTOR shall coordinate the work
5 performed by any subcontractor.

6 C. AUTHORITY shall have the right, but not the obligation, to review the form of any subcontract
7 used by CONTRACTOR for the project and to require modifications thereto to conform to the
8 requirements set forth herein.

9 **ARTICLE 21. ACCESS TO RECORDS AND REPORTS**

10 CONTRACTOR shall provide AUTHORITY, the U.S. Department of Transportation (DOT), the
11 Comptroller General of the United States, and their respective representatives, and any other agents of
12 AUTHORITY, such access to CONTRACTOR's accounting books, records, payroll documents and
13 facilities of the CONTRACTOR which are directly pertinent to this Agreement for the purposes of
14 examining, auditing and inspecting all accounting books, records, work data, documents and activities
15 related hereto. CONTRACTOR shall maintain such books, records, data and documents in accordance
16 with generally accepted accounting principles and shall clearly identify and make such items readily
17 accessible to such parties during CONTRACTOR's performance hereunder and for a period of four (4)
18 years from the date of final payment by AUTHORITY, except in the event of litigation or settlement of
19 claims arising from the performance of this Agreement, in which case CONTRACTOR agrees to maintain
20 same until AUTHORITY, or any of their duly authorized representatives, have disposed of all such
21 litigation, appeals, claims or exceptions related thereto. AUTHORITY's right to audit books and records
22 directly related to this Agreement shall also extend to all first-tier subcontractors. CONTRACTOR shall
23 permit any of the foregoing parties to reproduce documents by any means whatsoever or to copy excerpts
24 and transcriptions as reasonably necessary. CONTRACTOR agrees to include these requirements in all
25 subcontracts at any tier.

26 /

1 **ARTICLE 22. CONFLICT OF INTEREST**

2 CONTRACTOR agrees to avoid organizational conflicts of interest. An organizational conflict of
3 interest means that due to other activities, relationships or contracts, the CONTRACTOR is unable, or
4 potentially unable to render impartial assistance or advice to AUTHORITY; CONTRACTOR’s objectivity
5 in performing the work identified in the Scope of Work is or might be otherwise impaired; or
6 CONTRACTOR has an unfair competitive advantage. CONTRACTOR is obligated to fully disclose to
7 AUTHORITY in writing Conflict of Interest issues as soon as they are known to CONTRACTOR. All
8 disclosures must be submitted in writing to AUTHORITY pursuant to the Notice provision herein. This
9 disclosure requirement is for the entire term of this Agreement.

10 **ARTICLE 23. CODE OF CONDUCT**

11 CONTRACTOR agrees to comply with AUTHORITY’s Code of Conduct as it relates to Third-
12 Party contracts which is hereby referenced and by this reference is incorporated herein. CONTRACTOR
13 agrees to include these requirements in all of its subcontracts.

14 **ARTICLE 24. PROHIBITION ON PROVIDING ADVOCACY SERVICES**

15 CONTRACTOR and all subcontractors performing work under this Agreement, shall be
16 prohibited from concurrently representing or lobbying for any other party competing for a contract with
17 AUTHORITY, either as a prime contractor or subcontractor. Failure to refrain from such representation
18 may result in termination of this Agreement.

19 **ARTICLE 25. FEDERAL, STATE AND LOCAL LAWS**

20 CONTRACTOR warrants that, in the performance of this Agreement, it shall comply with all
21 applicable federal, state and local laws, statutes and ordinances and all lawful orders, rules and
22 regulations promulgated thereunder.

23 **ARTICLE 26. EQUAL EMPLOYMENT OPPORTUNITY**

24 During the performance of this Agreement, CONTRACTOR agrees as follows:

25 A. CONTRACTOR will not discriminate against any employee or applicant for employment
26 because of race, color, religion, sex, sexual orientation, gender identity, or national origin.

1 CONTRACTOR will take affirmative action to ensure that applicants are employed, and that employees
2 are treated during employment without regard to their race, color, religion, sex, sexual orientation, gender
3 identity, or national origin. Such action shall include, but not be limited to the following: Employment,
4 upgrading, demotion, or transfer; recruitment or recruitment advertising; layoff or termination; rates of pay
5 or other forms of compensation; and selection for training, including apprenticeship. CONTRACTOR
6 agrees to post in conspicuous places, available to employees and applicants for employment, notices to
7 be provided setting forth the provisions of this nondiscrimination clause.

8 B. CONTRACTOR will, in all solicitations or advertisements for employees placed by or on behalf
9 of CONTRACTOR, state that all qualified applicants will receive consideration for employment without
10 regard to race, color, religion, sex, sexual orientation, gender identity, or national origin.

11 C. CONTRACTOR will not discharge or in any other manner discriminate against any employee
12 or applicant for employment because such employee or applicant has inquired about, discussed, or
13 disclosed the compensation of the employee or applicant or another employee or applicant. This
14 provision shall not apply to instances in which an employee who has access to the compensation
15 information of other employees or applicants as a part of such employee's essential job functions
16 discloses the compensation of such other employees or applicants to individuals who do not otherwise
17 have access to such information, unless such disclosure is in response to a formal complaint or charge,
18 in furtherance of an investigation, proceeding, hearing, or action, including an investigation conducted by
19 the employer, or is consistent with CONTRACTOR's legal duty to furnish information.

20 D. CONTRACTOR will send to each labor union or representative of workers with which
21 CONTRACTOR has a collective bargaining agreement or other contract or understanding, a notice to be
22 provided advising the said labor union or workers' representatives of CONTRACTOR's commitments
23 under this Article, and shall post copies of the notice in conspicuous places available to employees and
24 applicants for employment.

25 E. CONTRACTOR will comply with all provisions of Executive Order 11246 of
26 September 24, 1965, and of the rules, regulations, and relevant orders of the Secretary of Labor.

1 F. CONTRACTOR will furnish all information and reports required by Executive Order 11246 of
2 September 24, 1965, and by rules, regulations, and orders of the Secretary of Labor, or pursuant thereto,
3 and will permit access to CONTRACTOR's books, records, and accounts by the DOT and the Secretary
4 of Labor for purposes of investigation to ascertain compliance with such rules, regulations, and orders.

5 G. In the event of CONTRACTOR's noncompliance with the nondiscrimination clauses of this
6 Agreement or with any of the said rules, regulations, or orders, this Agreement may be canceled,
7 terminated, or suspended in whole or in part and CONTRACTOR may be declared ineligible for further
8 Government contracts or federally-assisted construction contracts in accordance with procedures
9 authorized in Executive Order 11246 of September 24, 1965, and such other sanctions may be imposed
10 and remedies invoked as provided in Executive Order 11246 of September 24, 1965, or by rule,
11 regulation, or order of the Secretary of Labor, or as otherwise provided by law.

12 H. CONTRACTOR will include the portion of the sentence immediately preceding Paragraph (A)
13 and the provisions of Paragraphs (A) through (H) of this Article in every subcontract or purchase order
14 unless exempted by rules, regulations, or orders of the Secretary of Labor issued pursuant to
15 Section 204 of Executive Order 11246 of September 24, 1965, so that such provisions will be binding
16 upon each subcontractor or vendor. CONTRACTOR will take such action with respect to any subcontract
17 or purchase order as the DOT may direct as a means of enforcing such provisions, including sanctions
18 for noncompliance: provided, however, that in the event CONTRACTOR becomes involved in, or is
19 threatened with, litigation with a subcontractor or vendor as a result of such direction by the DOT,
20 CONTRACTOR may request the United States to enter into such litigation to protect the interests of the
21 United States.

22 **ARTICLE 27. FINISHED AND PRELIMINARY DATA**

23 A. All of CONTRACTOR's finished technical data, including but not limited to illustrations,
24 photographs, tapes, software, software design documents, including without limitation source code,
25 binary code, all media, technical documentation and user documentation, photoprints and other graphic
26 information required to be furnished under this Agreement, shall be AUTHORITY's property upon

1 payment and shall be furnished with unlimited rights and, as such, shall be free from proprietary restriction
2 except as elsewhere authorized in this Agreement. CONTRACTOR further agrees that it shall have no
3 interest or claim to such finished, AUTHORITY-owned, technical data; furthermore, said data is subject
4 to the provisions of the Freedom of Information Act, Title 5 of the United States Code (U.S.C.)
5 Section 552.

6 B. It is expressly understood that any title to preliminary technical data is not passed to
7 AUTHORITY but is retained by CONTRACTOR. Preliminary data includes roughs, visualizations,
8 software design documents, layouts and comprehensives prepared by CONTRACTOR solely for the
9 purpose of demonstrating an idea or message for AUTHORITY's acceptance before approval is given
10 for preparation of finished artwork. Preliminary data title and right thereto shall be made available to
11 AUTHORITY if CONTRACTOR causes AUTHORITY to exercise Article 17, and a price shall be
12 negotiated for all preliminary data.

13 **ARTICLE 28. NONDISCRIMINATION**

14 A. Nondiscrimination: In accordance with Federal transit law at 49 U.S.C. Section 5332,
15 CONTRACTOR agrees that it will not discriminate against any employee or applicant for employment
16 because of race, color, religion, national origin, sex, disability, or age. CONTRACTOR agrees to comply
17 with all applicable regulations and other implementing requirements the Federal Transit Administration
18 (FTA) may issue.

19 B. Race, Color, Creed, National, Origin, Sex: In accordance with Title VII of the Civil Rights
20 Act, as amended, 42 U.S.C. Section 2000e et seq.; and Federal transit laws at 49 U.S.C. Section 5332;
21 CONTRACTOR agrees to comply with all applicable equal employment opportunity requirements of
22 U.S. Department of Labor (U.S. DOL) regulations, "Office of Federal Contract Compliance Programs,
23 Equal Employment Opportunity, Department of Labor;" 41 CFR part 60; and Executive
24 Order No. 11246, "Equal Employment Opportunity in Federal Employment," September 24, 1965,
25 42 U.S.C. Section 2000e note, as amended by any later Executive Order that amends or supersedes
26 it, referenced in 42 U.S.C. Section 2000e. CONTRACTOR further agrees to comply with Title VI of the

1 Civil Rights Act, as amended, 42 U.S.C. Section 2000d et seq.; 49 CFR part 21; the most recent
2 version of FTA Circular 4702.1B, "Title VI Requirements and Guidelines for Federal Transit
3 Administration Recipients;" DOT Order 5610.2(a) to Address Environmental Justice in Minority
4 Populations and Low Income Populations;" Executive Order No. 13166 and DOT Policy Guidance
5 concerning Recipients' Responsibilities to Limited English Proficiency (70 FR 74087, Dec. 14, 2005);
6 and the most recent version of FTA Circular 4704.1 "Equal Employment Program Guidelines for Grant
7 Recipients," as applicable. CONTRACTOR agrees to comply with any implementing requirements FTA
8 may issue.

9 C. Age: In accordance with the Age Discrimination in Employment Act, 29 U.S.C.
10 Sections 621-634; U.S. Equal Employment Opportunity Commission regulations, "Age Discrimination in
11 Employment Act," 29 C.F.R. part 1625; the Age Discrimination Act of 1975, as amended, 42 U.S.C.
12 Section 6101 et seq.; U.S. Health and Human Services regulations, "Nondiscrimination on the Basis of
13 Age in Programs or Activities Receiving Federal Financial Assistance," 45 CFR part 90; and Federal
14 transit law at 49 U.S.C. Section 5332; CONTRACTOR agrees to refrain from discrimination against
15 present and prospective employees for reason of age. CONTRACTOR agrees to comply with
16 implementing requirements FTA may issue.

17 D. Disabilities: In accordance with Section 504 of the Rehabilitation Act of 1973, as amended,
18 29 U.S.C. Section 794; the Americans with Disabilities Act of 1990, as amended, 42 U.S.C. Section
19 12101 et seq.; the Architectural Barriers Act of 1968, as amended, 42 U.S.C. Section 4151 et seq.,
20 and Federal transit law at 49 U.S.C. Section 5332; CONTRACTOR agrees that it will not discriminate
21 against individuals on the basis of disability. CONTRACTOR agrees to comply with all applicable
22 implementing regulations and requirements FTA may issue, including 49 CFR parts 27, 37, 38, and 39
23 and the most recent version of FTA Circular 4710.1 "Americans with Disabilities Act: Guidance."

24 E. DISADVANTAGED BUSINESS ENTERPRISE (DBE): CONTRACTOR, AUTHORITY or
25 subcontractor shall not discriminate on the basis of race, color, national origin, or sex in the performance
26 of this Contract. CONTRACTOR shall carry out applicable requirements of 49 CFR Part 26 in the award

1 and administration of U.S. DOT-assisted contracts. Failure by CONTRACTOR to carry out these
2 requirements is a material breach of this contract, which may result in the termination of this contract or
3 such other remedy as the AUTHORITY deems appropriate, which may include, but is not limited to:

- 4 (1) Withholding monthly progress payments;
- 5 (2) Assessing sanctions;
- 6 (3) Liquidated damages; and/or
- 7 (4) Disqualifying the CONTRACTOR from future bidding/proposing as non-responsible.

8 CONTRACTOR agrees to include these requirements in all subcontracts at any tier.

9 **ARTICLE 29. DISADVANTAGED BUSINESS ENTERPRISES**

10 A. At the time of Agreement execution, CONTRACTOR committed to utilize one or more
11 Disadvantaged Business Enterprise (“DBE”) firms in the performance of this U.S. DOT-assisted contract.
12 CONTRACTOR agrees to ensure that any DBE subcontractor listed on the “DBE Participation
13 Commitment Form” (Attachment A-1), will perform work and/or supply materials pursuant to all original
14 commitments, unless otherwise directed and/or approved by AUTHORITY prior to CONTRACTOR
15 effectuating any changes to its DBE participation commitment. CONTRACTOR shall comply with all the
16 requirements set forth in Attachment “A” entitled, “DISADVANTAGED BUSINESS ENTERPRISE (DBE)
17 CONTRACT PROVISIONS FOR U.S. DOT-ASSISTED CONTRACTS,” which is attached to, and
18 incorporated herein by reference to this Agreement.

19 **ARTICLE 30. PRIVACY ACT**

20 A. CONTRACTOR shall comply with, and assures the compliance of its employees with, the
21 information restrictions and other applicable requirements of the Privacy Act of 1974, 5 U.S.C. Section
22 552(a). Among other things, CONTRACTOR agrees to obtain the express consent of the Federal
23 Government before CONTRACTOR or its employees operate a system of records on behalf of the
24 Federal Government. CONTRACTOR understands the requirements of the Privacy Act, including the
25 civil and criminal penalties for violation of that Act, apply to those individuals involved, and that failure to
26 comply with the terms of the Privacy Act may result in termination of the underlying Agreement.

1 B. CONTRACTOR agrees to include this requirement in all of its subcontracts.

2 **ARTICLE 31. OWNERSHIP OF REPORTS AND DOCUMENTS**

3 A. The originals of all letters, documents, reports and other products and data produced under
4 this Agreement shall be delivered to, and become the property of AUTHORITY. Copies may be made
5 for CONTRACTOR's records but shall not be furnished to others without written authorization from
6 AUTHORITY. Such deliverables shall be deemed works made for hire and all rights in copyright therein
7 shall be retained by AUTHORITY.

8 B. All ideas, memoranda, specifications, plans, manufacturing, procedures, drawings,
9 descriptions, and all other written information submitted to CONTRACTOR in connection with the
10 performance of this Agreement shall not, without prior written approval of AUTHORITY, be used for any
11 purposes other than the performance under this Agreement, nor be disclosed to an entity not connected
12 with the performance of the project. CONTRACTOR shall comply with AUTHORITY's policies regarding
13 such material. Nothing furnished to CONTRACTOR, which is otherwise known to CONTRACTOR or is
14 or becomes generally known to the related industry shall be deemed confidential. CONTRACTOR shall
15 not use AUTHORITY's name, photographs of the project, or any other publicity pertaining to the project
16 in any professional publication, magazine, trade paper, newspaper, seminar or other medium without the
17 express written consent of AUTHORITY.

18 C. No copies, sketches, computer graphics or graphs, including graphic artwork, are to be
19 released by CONTRACTOR to any other person or agency except after prior written approval by
20 AUTHORITY, except as necessary for the performance of services under this Agreement. All press
21 releases, including graphic display information to be published in newspapers, magazines, etc., are to be
22 handled only by AUTHORITY unless otherwise agreed to by CONTRACTOR and AUTHORITY.

23 **ARTICLE 32. INCORPORATION OF FTA TERMS**

24 All contractual provisions required by the DOT, whether or not expressly set forth in this document,
25 as set forth in FTA Circular 4220.1F, are hereby incorporated by reference. Anything to the contrary
26 herein notwithstanding, all FTA mandated terms shall be deemed to control in the event of a conflict with

1 other provisions contained in this Agreement. CONTRACTOR shall not perform any act, fail to perform
2 any act, or refuse to comply with any AUTHORITY requests, which would cause AUTHORITY to be in
3 violation of the FTA terms and conditions.

4 **ARTICLE 33. FEDERAL CHANGES**

5 CONTRACTOR shall at all times comply with all applicable FTA regulations, policies, procedures
6 and directives, including without limitation those listed directly or by reference in the agreement between
7 AUTHORITY and FTA, as they may be amended or promulgated from time to time during this Agreement.
8 CONTRACTOR's failure to comply shall constitute a material breach of Agreement.

9 **ARTICLE 34. NO GOVERNMENT OBLIGATION TO THIRD PARTIES**

10 AUTHORITY and CONTRACTOR acknowledge and agree that, notwithstanding any
11 concurrence by the Federal Government in or approval of the solicitation or award of the underlying
12 Agreement, absent the express written consent by the Federal Government, the Federal Government is
13 not a party to this Agreement and shall not be subject to any obligations or liabilities to AUTHORITY,
14 CONTRACTOR, or any other party (whether or not a party to this Agreement) pertaining to any matter
15 resulting from the underlying Agreement. CONTRACTOR agrees to include this requirement in all of its
16 subcontracts.

17 **ARTICLE 35. PROGRAM FRAUD AND FALSE OR FRAUDULENT STATEMENTS AND**
18 **ACTS**

19 A. CONTRACTOR acknowledges that the provisions of the Program Fraud Civil Remedies Act
20 of 1986, as amended, 31 U.S.C. Sections 3801 et seq. and DOT regulations, "Program Fraud Civil
21 Remedies," 49 CFR Part 31, apply to its actions pertaining to this project. By execution of this Agreement,
22 CONTRACTOR certifies or affirms the truthfulness and accuracy of any statement it has made, it makes,
23 it may make, or causes to be made, pertaining to the underlying Agreement of the FTA assisted project
24 for which this Agreement's work is being performed. In addition to other penalties that may be applicable,
25 CONTRACTOR acknowledges that if it makes, or causes to be made, a false, fictitious, or fraudulent
26 claim, statement, submission, or certification, the Federal Government reserves the right to impose

1 penalties of the Program Fraud Civil Remedies Act of 1986 on the CONTRACTOR to the extent the
2 Federal Government deems appropriate.

3 B. CONTRACTOR also acknowledges that if CONTRACTOR makes, or causes to be made, a
4 false, fictitious, or fraudulent claim, statement, submission, or certification to the Federal Government
5 under an agreement connected with a project that is financed in whole or part with Federal assistance
6 awarded by FTA under the authority of 49 U.S.C. Chapter 53, the Federal Government reserves the right
7 to impose the penalties of 18 U.S.C. Section 1001 and 49 U.S.C. Section 5323 on the CONTRACTOR,
8 to the extent the Federal Government deems appropriate. CONTRACTOR agrees to include this
9 requirement in all of its subcontracts.

10 **ARTICLE 36. CONVICT LABOR**

11 In connection with the performance of work under this Agreement, CONTRACTOR agrees not to
12 employ any person undergoing sentence of imprisonment at hard labor. This does not include convicts
13 who are on parole or probation.

14 **ARTICLE 37. NOTICE OF LABOR DISPUTE**

15 Whenever CONTRACTOR has knowledge that any actual or potential labor dispute may delay
16 its performance under this Agreement, CONTRACTOR shall immediately notify and submit all relevant
17 information to AUTHORITY. CONTRACTOR shall insert the substance of this entire clause in any
18 subcontract hereunder as to which a labor dispute may delay performance under this Agreement.
19 However, any subcontractor need give notice and information only to its next higher-tier subcontractor.

20 **ARTICLE 38. LIQUIDATED DAMAGES**

21 If CONTRACTOR fails to complete the work within the time specified in Article 4 of this
22 Agreement, or any AUTHORITY authorized extension thereof, the actual damage to AUTHORITY for the
23 delay will be difficult or impossible to determine. Therefore, in lieu of actual damages, CONTRACTOR
24 shall pay to AUTHORITY as fixed, agreed-to liquidated damages for each calendar day of delay the sum
25 of Nine Hundred Dollars (\$900.00). Alternatively, AUTHORITY may terminate this Agreement in whole
26 or in part as provided in Article 17 of this Agreement, and in that event, CONTRACTOR shall be liable, in

1 addition to the excess costs provided in Article 17 of this Agreement, for such liquidated damages
2 accruing until such time as AUTHORITY may reasonably obtain delivery or performance of similar
3 supplies or services from a different source. CONTRACTOR shall not be charged with liquidated
4 damages when the delay is determined to be excusable in accordance with Article 59 hereunder.
5 AUTHORITY shall ascertain the facts and extent of the delay and shall extend the time for performance
6 of the Agreement when in its judgment, the findings of fact justify an extension.

7 **ARTICLE 39. WARRANTY**

8 A. In addition to any other warranties set forth in this Agreement, whether expressed or implied,
9 CONTRACTOR warrants that (1) all work performed and all equipment and material provided under this
10 Agreement by CONTRACTOR or any of its subcontractors or suppliers at any tier, conforms to the
11 requirements herein and is free of any defects; (2) equipment furnished by CONTRACTOR or any of its
12 subcontractors or suppliers at any tier, shall be of modern design, in good working condition and fit for
13 use of its intended purpose; and (3) all work shall meet all of the requirements of this Agreement. Such
14 warranty shall continue for a period of one (1) year from AUTHORITY's acceptance as shown in
15 Article 42 hereunder. Under this warranty, CONTRACTOR shall remedy at its own expense any such
16 failure to conform or correct any such defect. In addition, CONTRACTOR shall remedy at its own
17 expense any damage to AUTHORITY owned or controlled real or personal property, when that damage
18 is the result of CONTRACTOR's failure to conform to Agreement requirements or any such defect of
19 equipment, material, workmanship or design. CONTRACTOR shall also restore any work damaged in
20 fulfilling the terms of this clause. CONTRACTOR's warranty with respect to work repaired or replaced
21 hereunder will run for one year from the date of such repair or replacement.

22 B. AUTHORITY shall notify CONTRACTOR in writing within a reasonable time after the
23 discovery of any failure, defect or damage. CONTRACTOR has seven (7) days from receipt of notice
24 from AUTHORITY to respond to AUTHORITY's notification and indicate how CONTRACTOR will remedy
25 the failure, defect, or damage. If AUTHORITY is not satisfied with the remedy proposed by
26 CONTRACTOR, CONTRACTOR and AUTHORITY shall meet and mutually agree when and how

1 CONTRACTOR shall remedy such violation. In the case of an emergency requiring immediate corrective
2 action, CONTRACTOR shall implement such action, as it deems necessary and shall notify AUTHORITY
3 in writing of the urgency of a decision and action taken. CONTRACTOR and AUTHORITY shall, then
4 promptly meet in order to agree on a remedy. If CONTRACTOR and AUTHORITY fail to agree on the
5 remedy within a five (5)-day period, AUTHORITY, after notice to CONTRACTOR, shall have the right to
6 perform or have performed by third parties the necessary remedy, and the costs thereof shall be borne
7 by CONTRACTOR.

8 C. Should CONTRACTOR fail to remedy any failure, defect or damage described in paragraph
9 A above within a reasonable time after receipt of notice thereof, AUTHORITY shall have the right to
10 replace, repair or otherwise remedy such failure, defect or damage at CONTRACTOR's expense and
11 CONTRACTOR shall be liable for all damages, including, but not limited to, actual or consequential
12 damages and cost of any suit to enforce AUTHORITY's rights hereunder, including reasonable attorney's
13 fees.

14 D. In addition to the other rights and remedies provided by this clause, all subcontractors,
15 manufacturers, and suppliers' warranties, expressed or implied, respecting any work and materials
16 furnished hereunder, shall, at the direction of AUTHORITY, be enforced by CONTRACTOR for the benefit
17 of AUTHORITY. In such case if CONTRACTOR's warranty under paragraph A above has expired, any
18 suit directed by AUTHORITY shall be at the expense of AUTHORITY. CONTRACTOR shall obtain any
19 warranties, which the subcontractors, manufacturers or suppliers would give in normal commercial
20 practice and shall cause all subcontractor or supplier warranties to be extend to AUTHORITY.

21 E. If directed by AUTHORITY, CONTRACTOR shall require any such warranties to be executed
22 in writing to AUTHORITY.

23 F. Notwithstanding any other provision of this clause, unless such a defect is caused by the
24 negligence of CONTRACTOR or its subcontractors or suppliers at any tier, CONTRACTOR shall not be
25 liable for the repair of any defects of material or design furnished by AUTHORITY nor for the repair of any
26 damage which results from any such defect in AUTHORITY furnished material or design.

1 G. The warranty specified herein shall not limit AUTHORITY's rights under the Inspection and
2 Acceptance clause of this Agreement with respect to latent defects, gross mistakes or fraud.

3 H. Defects in design or manufacture of equipment specified by AUTHORITY on a "brand name
4 and model" basis shall not be included in this warranty. CONTRACTOR shall require any subcontractors,
5 manufacturers or suppliers thereof to execute their warranties in writing directly to AUTHORITY.

6 I. Any disagreement between AUTHORITY and CONTRACTOR relating to this Article shall be
7 subject to dispute resolution in accordance with Article 16.

8 **ARTICLE 40. GENERAL WAGE RATES AND DAVIS-BACON AND COPELAND ANTI-**
9 **KICKBACK ACTS**

10 A. State Prevailing Wage and Labor Code Requirements. Notice is hereby given that, in
11 accordance with the provisions of California Labor Code, Division 2, Part 7, Chapter 1, Articles 1 and 2,
12 CONTRACTOR is required to pay not less than the general prevailing rate of per diem wages for work of
13 a similar character in the locality in which the public works is performed, and not less than the general
14 prevailing rate of per diem wages for holiday and overtime work. In that regard, the Director of the
15 Department of Industrial Relations of the State of California (DIR) is required to and has determined such
16 general prevailing rates of per diem wages. CONTRACTOR agrees to comply with the provisions of
17 California Labor Code Sections 1771, 1774 and 1775 concerning the payment of prevailing rates of
18 wages to workers and the penalties for failure to pay prevailing wages. Copies of such prevailing rates
19 of per diem wages may be obtained online at (<http://www.dir.ca.gov/>), are on file at the AUTHORITY's
20 office, and will be available to any interested party upon request. In accordance with the Labor Code, no
21 workman employed upon work under this Agreement shall be paid less than the above referenced
22 prevailing wage rate. A copy of said rates shall be posted at each job site during the course of
23 construction.

24 1. This Agreement is subject to compliance monitoring and enforcement by the DIR. The
25 DIR shall monitor and enforce compliance with applicable prevailing wage requirements for this
26 Agreement. The reporting requirements may be found at:

1 <https://www.dir.ca.gov/Public-Works/Contractors.html>. CONTRACTOR is responsible for complying
2 with all requirements of the DIR, including filing electronic payroll reports.

3 2. Pursuant to Labor Code Section 1771.1, CONTRACTOR and any subcontractor shall
4 not be qualified to bid on, be listed in a bid proposal, subject to the requirements of Section 4104 of the
5 Public Contract Code, or engage in the performance of any contract for public work on a public works
6 project unless registered with the DIR and qualified to perform public work pursuant to Labor Code
7 Section 1725.5. It is not a violation of Labor Code Section 1771.1 for an unregistered contractor to submit
8 a bid that is authorized by Business and Professions Code Section 7029.1 or by Public Contract Code
9 Section 10164 or 20103.5, provided CONTRACTOR is registered to perform public work pursuant to
10 Section 1725.5 at the time the contract is awarded. CONTRACTOR shall not perform any work under
11 this Agreement with any subcontractor who is ineligible to perform work on the public works project
12 pursuant to Section 1777.1 or 1777.7 of the Labor Code.

13 3. Pursuant to Labor Code Section 1771.4, CONTRACTOR will post all job site notices,
14 as prescribed by regulation.

15 4. CONTRACTOR, and all subcontractors, shall comply with the provisions of Labor
16 Code Sections 1777.5 and 1777.6 concerning the employment of apprentices. CONTRACTOR shall
17 have full responsibility for compliance with such Labor Code sections for all apprenticeable occupations,
18 regardless of any other contractual or employment relationships alleged to exist.

19 5. CONTRACTOR agrees to comply with the provisions of Labor Code Section 1776,
20 including the keeping of payroll records and furnishing certified copies thereof in accordance with said
21 Section and with the terms as set forth in Exhibit A, "General Provisions." CONTRACTOR is responsible
22 for compliance with Section 1776 by all subcontractors.

23 6. CONTRACTOR agrees to comply with all applicable Labor Code provisions governing
24 legal working hours and shall forfeit, as a penalty to AUTHORITY, twenty-five dollars (\$25.00) for each
25 laborer, workman or mechanic employed in the execution of the contract, by him or any sub-contractor
26 under him, upon any of the work hereinbefore mentioned, for each calendar day during which the laborer,

1 workman or mechanic is required or permitted to labor more than eight (8) hours in any one calendar day
2 and forty (40) hours in any one calendar week in violation of the Labor Code.

3 7. In accordance with the provisions of Labor Code Section 3700, CONTRACTOR will
4 be required to secure the payment of compensation to his or her employees.

5 **B. Federal Prevailing Wage Rates and Anti-Kickback.**

6 1. CONTRACTOR shall comply with the Davis-Bacon Act, 40 U.S.C
7 Sections 3141-3144 and Sections 3146-3148, as supplemented by U.S. DOL regulations at
8 29 CFR part 5, "Labor Standards Provisions Applicable to Contracts Governing Federally Financed and
9 Assisted Construction." Under 49 U.S.C. Section 5333(a), prevailing wage protections apply to laborers
10 and mechanics employed on FTA-assisted construction, alteration, or repair projects. In accordance with
11 the statute, CONTRACTOR shall pay wages to laborers and mechanics at a rate not less than the
12 prevailing wages specified in a wage determination made by the Secretary of Labor. CONTRACTOR
13 agrees to pay wages not less than once per week. CONTRACTOR shall comply with the Davis-Bacon
14 Labor Provisions of 2 CFR Section 5.5, as set forth in Exhibit A, "General Provisions."

15 2. CONTRACTOR shall comply with the Copeland "Anti-Kickback" Act (40 U.S.C.
16 Section 3145), as supplemented by U.S. DOL regulations at 29 CFR part 3, "Contractors and
17 Subcontractors on Public Building or Public Work Financed in Whole or in part by Loans or Grants from
18 the United States." CONTRACTOR is prohibited from inducing, by any means, any person employed in
19 the construction, completion, or repair of public work, to give up any part of the compensation to which
20 he or she is otherwise entitled.

21 **ARTICLE 41. CONTRACT WORK HOURS AND SAFETY STANDARDS**

22 A. If the maximum cumulative payment obligation of this Agreement exceeds \$100,000,
23 CONTRACTOR agrees to comply with the Federal Contract Work Hours and Safety Standards
24 (40 U.S.C. Section 3701 et seq. as supplemented by 29 CFR part 5). Under 40 U.S.C. Section 3702,
25 CONTRACTOR shall compute the wages of every mechanic and laborer, including watchmen and
26 guards, on the basis of a standard work week of forty (40) hours.

1 1. Overtime requirements: CONTRACTOR, and any subcontractor contracting for any
2 part of the contract work which may require or involve the employment of laborers or mechanics, shall
3 not require or permit any such laborer or mechanic in any workweek in which he or she is employed on
4 such work to work in excess of forty (40) hours in such workweek unless such laborer or mechanic
5 receives compensation at a rate not less than one and one-half (1.5) times the basic rate of pay for all
6 hours worked in excess of forty (40) hours in such workweek.

7 2. Violation; liability for unpaid wages; liquidated damages: In the event of any violation
8 of paragraph (A) of this Article, CONTRACTOR and any subcontractor responsible therefor shall be liable
9 for the unpaid wages. In addition, CONTRACTOR and subcontractor shall be liable to the United States
10 for liquidated damages. Such liquidated damages shall be computed with respect to each individual
11 laborer or mechanic, including watchmen and guards, employed in violation of the clause set forth in
12 paragraph (A) of this Article, in the sum of \$10 for each calendar day on which such individual was
13 required or permitted to work in excess of the standard workweek of forty (40) hours without payment of
14 the overtime wages required by paragraph (A) of this Article.

15 3. Withholding for unpaid wages and liquidated damages: FTA shall upon its own action
16 or upon written request of an authorized representative of the Department of Labor withhold or cause to
17 be withheld, from any moneys payable on account of work performed by CONTRACTOR or
18 subcontractor under any such contract or any other Federal contract with CONTRACTOR, or any other
19 federally-assisted contract subject to the Contract Work Hours and Safety Standards Act, which is held
20 by CONTRACTOR, such sums as may be determined to be necessary to satisfy any liabilities of
21 CONTRACTOR or subcontractor for unpaid wages and liquidated damages as provided in this Article.

22 4. Subcontracts: CONTRACTOR shall insert in any subcontracts the clauses set forth
23 in paragraphs (A) of this Article and also a clause requiring the subcontractors to include these clauses
24 in any lower tier subcontracts. CONTRACTOR shall be responsible for compliance by any subcontractor
25 or lower tier subcontractor with the clauses set forth in paragraph A of this Article.

26 /

1 B. CONTRACTOR agrees to comply with U.S. DOL Regulations, "Recording and Reporting
2 Occupational Injuries and Illnesses," 29 CFR part 1904; "Occupational Safety and Health Standards,"
3 29 CFR part 1910; and "Safety and Health Regulations for Construction," 29 CFR part 1926.

4 **ARTICLE 42. INSPECTION AND ACCEPTANCE**

5 A. All work (which term includes but is not restricted to materials, equipment, workmanship, and
6 manufacture and fabrication of components) shall be subject to inspection and test by AUTHORITY at all
7 reasonable times and at all places prior to acceptance. Any such inspection and test is for the sole benefit
8 of AUTHORITY and shall not relieve CONTRACTOR of the responsibility of providing quality control
9 measures to assure that the work strictly complies with requirements of this Agreement. No inspection
10 or test by AUTHORITY or its representative shall be construed as constituting or implying acceptance.
11 Any inspection or test shall not relieve CONTRACTOR of responsibility for damage to or loss of the
12 material prior to acceptance, nor in any way affect the continuing rights of AUTHORITY after acceptance
13 of the completed work under the terms of paragraph F of this Article, except as herein above provided.

14 B. CONTRACTOR shall, without charge, replace any material or correct any workmanship found
15 by AUTHORITY not to conform to the requirements of this Agreement, unless in the public interest
16 AUTHORITY consents to accept such material or workmanship with an appropriate adjustment in the
17 price of this Agreement. CONTRACTOR shall promptly segregate and remove rejected material from
18 the premises.

19 C. CONTRACTOR shall furnish promptly, without additional charge, all facilities, labor,
20 equipment and material reasonably needed for performing such safe and convenient inspection and test
21 as may be required by AUTHORITY. All inspections and tests by AUTHORITY shall be performed in
22 such manner as to not unnecessarily delay the work. AUTHORITY reserves the right to charge to
23 CONTRACTOR any additional cost of inspection or test when material or workmanship is not ready at
24 the time specified by CONTRACTOR for inspection or test or when reinspection or retest is necessitated
25 by prior rejection.

26 /

1 D. If CONTRACTOR does not promptly replace rejected material or correct rejected
2 workmanship, AUTHORITY (1) may, by Agreement or otherwise, replace such material or correct such
3 workmanship and charge the cost thereof to CONTRACTOR, or (2) may terminate CONTRACTOR's
4 right to proceed in accordance with the clause of this Agreement entitled "Termination for Default."

5 E. Should it be considered necessary or advisable by AUTHORITY at any time before
6 acceptance of the entire work to make an examination of work already completed, by removing or tearing
7 out same, CONTRACTOR shall, on request, promptly furnish all necessary facilities, labor and material.
8 If such work is found to be defective or nonconforming in any material respect, due to the fault of
9 CONTRACTOR or its subcontractors, CONTRACTOR shall pay all costs of such examination and of
10 satisfactory reconstruction. If, however, such work is found to meet the requirements of this Agreement,
11 an equitable adjustment shall be made in the Agreement price to compensate CONTRACTOR for the
12 additional services involved in such examination and reconstruction and, if completion of the work has
13 been delayed thereby, it shall in addition, be granted a suitable extension of time.

14 F. Unless otherwise provided in this Agreement, acceptance by AUTHORITY shall be made as
15 promptly as practicable after completion and inspection of all work required by this Agreement, or that
16 portion of the work that AUTHORITY determines can be accepted separately. Acceptance shall be final
17 and conclusive except as regards latent defects, fraud, or such gross mistakes as may amount to fraud
18 or as regards AUTHORITY's rights under the warranty provisions set forth herein.

19 **ARTICLE 43. MATERIAL AND WORKMANSHIP**

20 A. Unless otherwise specifically provided in this Agreement, all equipment, material, and articles
21 incorporated in the work covered by this Agreement are to be new and of the most suitable grade for the
22 purpose intended. Unless otherwise specifically provided in this Agreement, reference to any equipment,
23 material, article or patented process, by trade name, make or catalog number, shall be regarded as
24 establishing a standard of quality and shall not be construed as limiting competition, and CONTRACTOR
25 may, at its option, use any equipment, material, article or process which, in the judgment of AUTHORITY,
26 is equal to that named. CONTRACTOR shall furnish to AUTHORITY for its approval the name of the

1 manufacturer, the model number and other identifying data and information respecting the performance,
2 capacity, nature and rating of the machinery and mechanical and other equipment, which CONTRACTOR
3 contemplates incorporating in the work. When required by this Agreement or when called for by
4 AUTHORITY, CONTRACTOR shall furnish AUTHORITY, for approval, full information concerning the
5 material or articles, which it contemplates incorporating in the work. When so directed, samples shall be
6 submitted for approval at CONTRACTOR's expense, with all shipping charges prepaid. Machinery,
7 equipment, material and articles installed or used without required approval shall be at the risk of
8 subsequent rejection.

9 B. All work under this Agreement shall be performed in a skillful and workmanlike manner.
10 Notwithstanding the provisions of Article 3 hereof, AUTHORITY may, in writing, require CONTRACTOR
11 to remove from the work any employee AUTHORITY deems incompetent, careless or otherwise
12 objectionable.

13 **ARTICLE 44. NON-CONFORMING WORK**

14 A. Nonconforming work rejected by AUTHORITY shall be removed and replaced so as to
15 conform to the requirements of this Agreement, at CONTRACTOR's cost and without a time extension;
16 and CONTRACTOR shall promptly take all action necessary to prevent similar deficiencies from occurring
17 in the future. The fact that AUTHORITY may not have discovered the nonconforming work shall not
18 constitute an acceptance of such nonconforming work. If CONTRACTOR fails to correct any
19 nonconforming work within ten (10) days of receipt of notice from AUTHORITY requesting correction, or
20 if such nonconforming work cannot be corrected within ten (10) days, and CONTRACTOR fails to;
21 (1) provide to AUTHORITY a schedule for correcting any such nonconforming work acceptable to
22 AUTHORITY within such ten (10) day period, (2) commence such corrective work within such
23 ten (10) day period and (3) thereafter diligently prosecute such correction in accordance with such
24 approved schedule to completion, then AUTHORITY may cause the nonconforming work to be remedied
25 or removed and replaced and may deduct the cost of doing so from any moneys due or to become due
26 to CONTRACTOR and/or obtain reimbursement from CONTRACTOR for such cost.

1 B. If AUTHORITY agrees to accept any nonconforming work without requiring it to be fully
2 corrected, AUTHORITY shall be entitled to reimbursement of a portion of the contract price in an amount
3 equal to the greater of the amount deemed appropriate by AUTHORITY to provide compensation for
4 future maintenance and/or other costs relating to the nonconforming work, or 100% of CONTRACTOR's
5 cost savings associated with its failure to perform the work in accordance with Contract requirements.
6 Such reimbursement shall be payable to AUTHORITY within ten (10) days after CONTRACTOR's receipt
7 of an invoice thereof. CONTRACTOR acknowledges and agrees that AUTHORITY shall have sole
8 discretion regarding acceptance or rejection of nonconforming work and that AUTHORITY shall have
9 sole discretion with regard to the amount payable in connection therewith.

10 **ARTICLE 45. CONTRACTOR INSPECTION SYSTEM**

11 CONTRACTOR shall maintain an adequate inspection system and perform such inspections as
12 will assure that the work performed under this Agreement conforms to the specified requirements, and
13 shall maintain and make available to AUTHORITY adequate records of such inspections.

14 **ARTICLE 46. SUPERINTENDENCE BY CONTRACTOR**

15 CONTRACTOR, at all times during performance and until the work is completed and accepted,
16 shall give its personal superintendence to the work or have on the work a competent superintendent,
17 satisfactory to AUTHORITY and with authority to act for and on behalf of CONTRACTOR.

18 **ARTICLE 47. OTHER CONTRACTS**

19 AUTHORITY may undertake or award other agreements for additional work, and CONTRACTOR
20 shall fully cooperate with such other CONTRACTOR's and AUTHORITY's employees and carefully fit its
21 own work to such additional work as may be directed by AUTHORITY. CONTRACTOR shall not commit
22 or permit any act, which will interfere with the performance of work by any other CONTRACTOR or by
23 AUTHORITY.

24 **ARTICLE 48. INSPECTION OF SITE**

25 CONTRACTOR acknowledges that it has investigated and satisfied itself as to the conditions
26 affecting the work including, but not restricted to, those bearing upon transportation, disposal, handling

1 and storage of materials, availability of labor, water, electric power and roads and uncertainties of
2 weather, river stages, tides or similar physical conditions at the site, the conformation and conditions of
3 the ground, the character of equipment and facilities needed preliminary to and during prosecution of the
4 work. CONTRACTOR further acknowledges that it has satisfied itself as to the character, quality and
5 quantity of surface and subsurface materials or obstacles to be encountered insofar as this information
6 is reasonably ascertainable from an inspection of the site, including all exploratory work done by
7 AUTHORITY, as well as from information presented by the drawings and specifications made a part of
8 this Agreement. Any failure by CONTRACTOR to acquaint itself with the available information will not
9 relieve it from responsibility for the difficulty or cost of successfully performing the work. AUTHORITY
10 assumes no responsibility for any conclusions or interpretations made by CONTRACTOR on the basis
11 of the information made available by AUTHORITY.

12 **ARTICLE 49. DIFFERING SITE CONDITIONS**

13 A. CONTRACTOR shall immediately, and before such conditions are disturbed, notify
14 AUTHORITY in writing of: (1) subsurface or latent physical conditions at the site which differ materially
15 from those indicated in this Agreement, or (2) unknown physical conditions at the site, of an unusual
16 nature, which differ materially from those ordinarily encountered and generally recognized as inherent in
17 work of the character provided for in this Agreement. AUTHORITY will investigate the conditions within
18 three (3) business days of receipt of notification, and if it finds that such conditions do materially so differ
19 and cause an increase or decrease in CONTRACTOR's cost of, or the time required for, performance of
20 any part of the work under this Agreement, whether or not changed as a result of such conditions, an
21 equitable adjustment shall be made and the Agreement modified in writing accordingly.

22 B. No claim of CONTRACTOR under this Article shall be allowed unless CONTRACTOR has
23 given the written notice required above; no claim by CONTRACTOR for an equitable adjustment
24 hereunder shall be allowed if asserted after final payment under this Agreement.

25 /

26 /

1 **ARTICLE 50. SEISMIC SAFETY REQUIREMENTS**

2 CONTRACTOR agrees that the work performed under this Agreement will be accomplished in
3 accordance with the standards for Seismic Safety required in DOT's Seismic Safety Regulations
4 49 CFR part 41 and will certify compliance to the extent required by the regulation for such work.
5 CONTRACTOR shall ensure that all work performed under this Agreement including work performed by
6 a subcontractor is in compliance with the standards required by the Seismic Safety Regulations and the
7 certification of compliance issued on the project.

8 **ARTICLE 51. RECYCLED PRODUCTS**

9 CONTRACTOR shall comply with all the requirements of Section 6002 of the Resource
10 Conservation and Recovery Act (RCRA), as amended (42 U.S.C. Section 6962), including but not limited
11 to the regulatory provisions of 40 CFR part 247, and Executive Order 12873, as they apply to the
12 procurement of the items designated in subpart B of 40 CFR part 247. CONTRACTOR agrees to include
13 this requirement in all of its subcontracts.

14 **ARTICLE 52. ENERGY CONSERVATION REQUIREMENTS**

15 If the maximum cumulative payment obligation of this Agreement exceeds the Simplified
16 Acquisition Threshold, as defined in 48 CFR Subpart 2.1, CONTRACTOR shall comply with mandatory
17 standards and policies relating to energy efficiency, which are contained in the state energy conservation
18 plan issued in compliance with the Energy Policy Conservation Act.

19 **ARTICLE 53. CLEAN AIR**

20 CONTRACTOR shall comply with all applicable standards, orders or regulations issued pursuant
21 to the Clean Air Act, as amended, 42 U.S.C. Section 7401 et seq. CONTRACTOR shall report any
22 violations of use of prohibited facilities to the FTA and the United States Environmental Protection Agency
23 (US EPA). CONTRACTOR agrees to include this requirement in each subcontract exceeding Simplified
24 Acquisition Threshold.

25 /

26 /

1 **ARTICLE 54. CLEAN WATER REQUIREMENTS**

2 If the maximum cumulative payment obligation of this Agreement exceeds Simplified Acquisition
3 Threshold, as defined in 48 CFR Subpart 2.1, CONTRACTOR shall comply with all applicable standards,
4 orders or regulations issued pursuant to the Federal Water Pollution Control Act, as amended, 33 U.S.C.
5 Section 1251 et seq. CONTRACTOR shall report any violations of use of prohibited facilities to the FTA
6 and US EPA. CONTRACTOR agrees to include this requirement in each subcontract exceeding
7 Simplified Acquisition Threshold.

8 **ARTICLE 55. OPERATIONS AND STORAGE AREAS**

9 A. All operations of CONTRACTOR (including storage of materials and equipment) on
10 AUTHORITY-owned premises shall be confined to areas authorized or approved by AUTHORITY.
11 CONTRACTOR shall hold AUTHORITY and its officers and agents free and harmless from liability of any
12 nature occasioned by CONTRACTOR's operations.

13 B. Temporary building (storage sheds, shops, offices, etc.) may be erected by CONTRACTOR
14 with the written consent of AUTHORITY, and shall be built with labor and materials furnished by
15 CONTRACTOR without expense to AUTHORITY. Such temporary buildings and utilities shall remain
16 the property of CONTRACTOR and shall be removed by CONTRACTOR at its expense upon the
17 completion of the work. With the written consent of AUTHORITY, such buildings and utilities may be
18 abandoned and need not be removed.

19 C. CONTRACTOR shall, under regulations prescribed by AUTHORITY, use only established
20 roadways or construct and use such temporary roadways as may be authorized by AUTHORITY. Where
21 materials are transported in the prosecution of work, vehicles shall not be loaded beyond the loading
22 capacity recommended by the manufacturer of the vehicle or prescribed by any federal, state or local law
23 or regulation. When it is necessary to cross curbing or sidewalks, protection against damage shall be
24 provided by CONTRACTOR and any damaged roads, curbing or sidewalks shall be repaired by, or at
25 the expense of, CONTRACTOR.

26 /

1 **ARTICLE 56. BUY AMERICA**

2 A. If the maximum cumulative payment obligation of this Agreement exceeds one hundred fifty
3 thousand dollars (\$150,000), CONTRACTOR shall comply with the "Buy America" requirements of
4 49 U.S.C. Section 5323(j) and 49 CFR part 661, as amended, which provide that Federal funds may not
5 be obligated unless all steel, iron, and manufactured products used in FTA-funded projects are produced
6 in the United States, unless a waiver has been granted by FTA or the product is subject to a general
7 waiver.

8 B. CONTRACTOR shall furnish a Certificate of Compliance, conforming to the provisions of this
9 Article, for all steel and iron materials.

10 C. CONTRACTOR shall ensure all subcontractors at every tier comply with these requirements.

11 **ARTICLE 57. PROTECTION OF VEGETATION, UTILITIES, IMPROVEMENTS**

12 A. CONTRACTOR shall preserve and protect all existing vegetation such as trees, shrubs and
13 grass on or adjacent to the site of work which is not to be removed and which does not unreasonably
14 interfere with the construction work. Care will be taken in removing trees authorized for removal to avoid
15 damage to vegetation to remain in place. Any limbs or branches of trees broken during such operations
16 or by the careless operation of equipment, or by workmen, shall be trimmed with a clean cut and painted
17 with an approved tree pruning compound as directed by AUTHORITY.

18 B. CONTRACTOR shall protect from damage all existing improvements or utilities at or near the
19 site of the work, the location of which is made known to it, and will repair or restore any damage to such
20 facilities resulting from failure to comply with the requirements of this Agreement or the failure to exercise
21 reasonable care in the performance of the work. If CONTRACTOR fails or refuses to repair any such
22 damage promptly, AUTHORITY may have the necessary work performed and charge the cost to
23 CONTRACTOR.

24 **ARTICLE 58. CLEANING UP**

25 A. CONTRACTOR shall at all times keep the construction area, including storage areas used by
26 it, free from accumulations of waste material or rubbish, and prior to completion of the work remove any

1 rubbish from AUTHORITY owned premises and all tools, scaffolding, equipment and materials not the
2 property of AUTHORITY. Upon completion of the construction, CONTRACTOR shall leave the work and
3 premises in a clean, neat and workmanlike condition satisfactory to AUTHORITY.

4 B. After completion of all work on the project, and before making application for acceptance of
5 the work, CONTRACTOR shall clean the construction site, including all areas under the control of
6 AUTHORITY, that have been used by CONTRACTOR in connection with the work on the project and
7 remove all debris, surplus material and equipment, and all temporary construction or facilities of whatever
8 nature, unless otherwise approved by AUTHORITY. Final acceptance of the work by AUTHORITY will
9 be withheld until CONTRACTOR has satisfactorily complied with the foregoing requirements for final
10 cleanup of the project site.

11 C. Full compensation for conforming to the provisions in this Article, not otherwise provided for,
12 shall be considered as included in price of this Agreement and no additional compensation will be allowed
13 therefore.

14 **ARTICLE 59. USE AND POSSESSION TO COMPLETION**

15 AUTHORITY shall have the right to take possession of or use any completed or partially
16 completed part of the work. Prior to such possession or use, AUTHORITY shall furnish CONTRACTOR
17 an itemized list of work remaining to be performed or corrected on such portions of the project as are to
18 be possessed or used by AUTHORITY, provided that failure to list any item of work shall not relieve
19 CONTRACTOR of responsibility for compliance with the terms of this Agreement. Such possession or
20 use shall not be deemed an acceptance of any work under this Agreement. While AUTHORITY has such
21 possession or use, CONTRACTOR shall be relieved of the responsibility for the loss or damage to the
22 work resulting from AUTHORITY's possession or use. If such prior possession or use by AUTHORITY
23 delays the progress of the work or causes additional expense to CONTRACTOR, an equitable adjustment
24 in the Agreement price or the time of completion will be made and the Agreement shall be modified in
25 writing accordingly.

26 /

1 **ARTICLE 60. PROHIBITED INTERESTS**

2 A. CONTRACTOR covenants that, for the term of this Agreement, no director, officer or
3 employee of AUTHORITY, during his/her tenure in office or for one (1) year thereafter, shall have any
4 interest, direct or indirect, in this Agreement or the proceeds thereof.

5 B. No member of or delegates to the Congress of the United States shall have any interest, direct
6 or indirect, in this Agreement or the benefits thereof.

7 **ARTICLE 61. CONTRACTOR PURCHASED EQUIPMENT**

8 A. If during the course of this Agreement, additional equipment is required, which will be paid for
9 by AUTHORITY, CONTRACTOR must request prior written authorization from AUTHORITY's project
10 manager before making any purchase. As part of this purchase request, CONTRACTOR shall provide a
11 justification for the necessity of the equipment or supply and submit copies of three (3) competitive
12 quotations. If competitive quotations are not obtained, CONTRACTOR must provide the justification for
13 the sole source.

14 B. CONTRACTOR shall maintain an inventory record for each piece of equipment purchased
15 that will be paid for by AUTHORITY. The inventory record shall include the date acquired, total cost, serial
16 number, model identification, and any other information or description necessary to identify said
17 equipment or supply. A copy of the inventory record shall be submitted to AUTHORITY upon request.

18 C. At the expiration or termination of this Agreement, CONTRACTOR may keep the equipment
19 and credit AUTHORITY in an amount equal to its fair market value. Fair market value shall be determined,
20 at CONTRACTOR's expense, on the basis of an independent appraisal. CONTRACTOR may sell the
21 equipment at the best price obtainable and credit AUTHORITY in an amount equal to the sales price. If
22 the equipment is to be sold, then the terms and conditions of the sale must be approved in advance by
23 AUTHORITY's project manager.

24 D. Any subcontractor agreement entered into as a result of this Agreement shall contain all
25 provisions of this clause.

26 /

1 **ARTICLE 62. DEBARMENT AND SUSPENSION GUIDELINES**

2 CONTRACTOR shall not do business with a subcontractor or other participant who is debarred,
3 suspended or otherwise disqualified. CONTRACTOR shall comply with 2 CFR part 180, as adopted and
4 supplemented by 2 CFR part 1200. CONTRACTOR shall include the requirements in any lower tier
5 covered transaction it enters into.

6 **ARTICLE 63. HEALTH AND SAFETY SPECIFICATIONS**

7 CONTRACTOR shall comply with all requirements set forth in Exhibit I, Level 3 Safety
8 Specifications.

9 **ARTICLE 64. LOBBYING**

10 CONTRACTOR shall comply with the lobbying requirements of 31 U.S.C. Section 1352 and the
11 applicable regulations under 49 CFR part 20. If the maximum cumulative payment obligation of this
12 Agreement exceeds \$100,000, CONTRACTOR shall file both the "Certification of Restrictions on
13 Lobbying" and the "Disclosure of Lobbying Activities." CONTRACTOR shall also require each
14 subcontractor to certify to CONTRACTOR that subcontractor will not and has not used Federal
15 appropriated funds to pay any person or organization for influencing or attempting to influence an officer
16 or employee of any agency, a member of Congress, officer or employee of Congress, or an employee of
17 a member of Congress in connection with obtaining any Federal contract, grant or any other award
18 covered by 31 U.S.C. Section 1352. CONTRACTOR shall also require any subcontractor to disclose to
19 CONTRACTOR the name of any registrant under the Lobbying Disclosure Act of 1995 who has made
20 lobbying contacts on its behalf with non-Federal funds with respect to that Federal contract, grant or
21 award covered by 31 U.S.C. Section 1352.

22 **ARTICLE 65. TRANSPORTATION OF EQUIPMENT, MATERIALS OR COMMODITIES BY**
23 **OCEAN VESSEL**

24 A. CONTRACTOR shall utilize privately owned United States-flag commercial vessels to ship at
25 least 50% of the gross tonnage (computed separately for dry bulk carriers, dry cargo liners and tankers)

26 /

1 B. involved, whenever shipping any equipment, materials or commodities pursuant to this
2 section, to the extent such vessels are available at fair and reasonable rates for United States-flag
3 commercial vessels.

4 C. CONTRACTOR shall furnish within twenty (20) working days following the date of loading for
5 shipments originating within the United States, or within thirty (30) working days following the date of
6 loading for shipping originating outside the United States, a legible copy of a rated, "on-board" commercial
7 ocean bill-of lading in English for each shipment of cargo described in paragraph A of this Article to
8 AUTHORITY (through the prime CONTRACTOR in the case of subcontractor bills-of-lading) and to the
9 Division of National Cargo, Office of Market Development, Maritime Administration,
10 Washington, DC 20590, marked with appropriate identification of the project.

11 **ARTICLE 66. FLY AMERICA REQUIREMENTS**

12 A. CONTRACTOR agrees to comply with 49 U.S.C. 40118 (the "Fly America" Act) in accordance
13 with the General Services Administration's regulations at 41 CFR Part 301-10, which provide that
14 recipients and subrecipient of Federal funds and their contractors are required to use U.S. Flag air carriers
15 for U.S. Government-financed international air travel and transportation of their personal effects or
16 property, to the extent such service is available, unless travel by foreign air carrier is a matter of necessity,
17 as defined by the Fly America Act. CONTRACTOR shall submit, if a foreign air carrier was used, an
18 appropriate certification or memorandum adequately explaining why service by a U.S. flag air carrier was
19 not available or why it was necessary to use a foreign air carrier and shall, in any event, provide a
20 certificate of compliance with the Fly America requirements. CONTRACTOR agrees to include the
21 requirements of this section in all subcontracts that may involve international air transportation.

22 **ARTICLE 67. CLAYTON AND CARTWRIGHT ACT**

23 In entering into a public works contract or a subcontract to supply goods, services, or materials
24 pursuant to this Agreement, CONTRACTOR and any subcontractor offers and agrees to assign to
25 AUTHORITY all rights, title, and interest in and to all causes of action it may have under Section 4 of the
26 Clayton Act (15 U.S.C. Section 15) or under the Cartwright Act (Chapter 2 (commencing with

1 Section 16700) of Part 2 of Division 7 of the Business and Professions Code), arising from purchases of
2 goods, services, or materials pursuant to the public works contract or subcontract entered into for
3 purposes of this Agreement. This assignment shall be made and become effective at the time the
4 AUTHORITY tenders final payment to the CONTRACTOR, without further acknowledgment by the
5 parties.

6 **ARTICLE 68. FORCE MAJEURE**

7 Either party shall be excused from performing its obligations under this Agreement during the time
8 and to the extent that it is prevented from performing by an unforeseeable cause beyond its control,
9 including but not limited to: any incidence of fire, flood; acts of God; commandeering of material, products,
10 plants or facilities by the federal, state or local government; national fuel shortage; or a material act or
11 omission by the other party; when satisfactory evidence of such cause is presented to the other party,
12 and provided further that such nonperformance is unforeseeable, beyond the control and is not due to
13 the fault or negligence of the party not performing.

14 /

15 /

16 /

17 /

18 /

19 /

20 /

21 /

22 /

23 /

24 /

25 /

26 /

**DISADVANTAGED BUSINESS ENTERPRISE (DBE) CONTRACT PROVISIONS FOR
U.S. DOT-ASSISTED CONTRACTS**

I. DBE Participation

It is the CONTRACTOR's responsibility to be fully informed regarding the requirements of 49 CFR, Part 26 and AUTHORITY's DBE program developed pursuant to these regulations.

If CONTRACTOR has committed to utilize a DBE in the performance of this U.S. DOT-assisted contract, CONTRACTOR's submitted "DBE Participation Commitment Form," in combination with the executed subcontract and/or purchase order will be utilized to monitor CONTRACTOR's DBE commitment. Unless otherwise directed and/or approved by AUTHORITY prior, CONTRACTOR must not effectuate any changes to its DBE participation commitment.

CONTRACTOR must complete and submit all required DBE documentation to effectively capture DBE utilization on AUTHORITY's U.S. DOT-assisted contracts whether achieved race neutrally or race consciously. No changes to CONTRACTOR's DBE commitment shall be made until proper review and approval by AUTHORITY is rendered in writing.

To ensure full compliance with the requirements of 49 CFR, Part 26 and AUTHORITY's DBE Program, CONTRACTOR must:

- A. Take appropriate actions to ensure that it will satisfy good faith efforts to meet the DBE agreement goal and continue to meet the DBE commitment made at award, when change orders or other modifications alter the dollar amount of the Agreement or the distribution of work. CONTRACTOR must apply and report its DBE goal commitment against the total Agreement value, including any change orders and/or amendments.

II. DBE Policy and Applicability

In accordance with federal financial assistance agreements with the U.S. Department of Transportation ("U.S. DOT"), AUTHORITY has adopted a Disadvantaged Business Enterprise ("DBE") Policy and Program in conformance with Title 49 CFR, Part 26, "Participation by Disadvantaged Business Enterprises in Department of Transportation Financial Assistance Programs".

The project is subject to these stipulated regulations and AUTHORITY's DBE Program. To ensure that AUTHORITY achieves its overall DBE Program goals and objectives, AUTHORITY encourages the participation of DBEs as defined in 49 CFR, Part 26, in the performance of agreements financed in whole or in part with U.S. DOT funds. Pursuant to the intent of these Regulations, it is also the policy of AUTHORITY to:

Fulfill the spirit and intent of the DBE Program regulations published under U.S. DOT Title 49 CFR, Part 26, by ensuring that DBEs have an equitable opportunity to compete for and participate in AUTHORITY's U.S. DOT-assisted contracts and subcontracts. AUTHORITY is firmly committed to the DBE Program objectives, which are designed to:

- A. Ensure non-discrimination in the award and administration of AUTHORITY's U.S. DOT-assisted contracts;
- B. Create a level playing field by which DBE's can fairly compete for AUTHORITY's U.S. DOT-assisted contracts;
- C. Ensure that AUTHORITY's DBE Program and Overall Goals are narrowly tailored in accordance with applicable law;
- D. Ensure that only firms that fully meet 49 CFR, Part 26 eligibility standards are permitted to participate as DBE's in the AUTHORITY's DBE Program;
- E. Help remove barriers which impede the participation of DBE's in AUTHORITY's U.S. DOT-assisted contracts;
- F. Promote the use of DBE's in all types of U.S. DOT-assisted contracts and procurement activities conducted by AUTHORITY;
- G. Provide training and other assistance through our resource partners to address capital, bonding, and insurance needs;
- H. Assist in the development of DBE firms that can compete successfully in the marketplace outside of the DBE Program; and
- I. Establish and provide opportunities for DBEs by providing flexibility in the implementation of AUTHORITY's DBE Program.

CONTRACTOR must not discriminate on the basis of race, color, national origin, or sex in the award and performance of subcontractor. Any terms used in this section that are defined in 49 CFR, Part 26, or elsewhere in the Regulations, must have the meaning set forth in the Regulations. In the event of any conflicts or inconsistencies between the Regulations and AUTHORITY's DBE Program with respect to U.S. DOT-assisted contracts, the Regulations must prevail.

III. AUTHORITY's DBE Policy Implementation Directives

Pursuant to the provisions associated with Title 49 CFR, Part 26, the Disadvantaged Business Enterprise ("DBE") Program exists to ensure participation, equitable competition, and assistance

to participants in the U.S. DOT DBE program. Accordingly, based on the AUTHORITY's analysis of its past utilization data, coupled with Overall Goal Methodology findings and examination of similar Agencies' disparity studies, AUTHORITY's DBE Program is implemented utilizing both race-conscious and race-neutral means. When a contract-specific DBE goal is assigned to a project, meeting the contract-specific goal by committing to utilize DBEs, or documenting a bona fide good faith effort to do so, is a condition of award.

A. Definitions

The following definitions apply to the terms used in these provisions:

1. ***"Disadvantaged Business Enterprise (DBE)"*** means a small business concern:
(a) which is at least fifty-one percent (51%) owned by one or more socially and economically disadvantaged individuals or, in the case of any publicly-owned business, at least fifty-one percent (51%) of the stock of which is owned by one or more socially and economically disadvantaged individuals; and (b) whose management and daily business operations are controlled by one or more of the socially and economically disadvantaged individuals who own it.

2. ***"Small Business Concern"*** means a small business as defined pursuant to Section 3 of the Small Business Act and Small Business Administration (SBA) regulations implementing it (13 CFR Part 121) that also does not exceed the cap on average annual gross receipts specified in §26.65(b).

3. ***"Socially and Economically Disadvantaged Individuals"*** means any individual who is a citizens (or lawfully admitted permanent resident) of the United States and who has been subjected to racial or ethnic prejudice or cultural bias within American society because of his or her identity as a member of groups and without regard to his or her individual qualities. The social disadvantage must stem from circumstances beyond the individual's control.
 - a) Any individual who a recipient finds to be a socially and economically disadvantaged individual on a case-by-case basis. An individual must demonstrate that he or she has held himself or herself out, as a member of a designated group if you require it.

 - b) Any individual in the following groups, members of which are rebuttably presumed to be socially and economically disadvantaged:
 - i. "Black Americans," which includes persons having origins in any of the Black racial groups of Africa";
 - ii. "Hispanic Americans," which includes persons of Mexican, Puerto Rican, Cuban, Dominican, Central or South American, or other Spanish or Portuguese culture or origin, regardless of race";

- iii. "Native Americans," which includes persons who are enrolled members of a federally or State recognized Indian tribe, Alaskan Natives, or Native Hawaiians”;
 - iv. "Asian-Pacific Americans," which includes persons whose origins are from Japan, China, Taiwan, Korea, Burma (Myanmar), Vietnam, Laos, Cambodia (Kampuchea), Thailand, Malaysia, Indonesia, the Philippines, Brunei, Samoa, Guam, the U.S. Trust Territories of the Pacific Islands (Republic of Palau), Republic of the Northern Marianas Islands, Samoa, Macao, Fiji, Tonga, Kirbati, Tuvalu, Nauru, Federated States of Micronesia, or Hong Kong”;
 - v. "Subcontinent Asian Americans," which includes persons whose origins are from India, Pakistan, Bangladesh, Bhutan, the Maldives Islands, Nepal or Sri Lanka;”
 - vi. Women; and
 - vii. Any additional groups whose members are designated as socially and economically disadvantaged by the SBA, at such time as the SBA designation becomes effective.
- c) Being born in a particular country does not, standing alone, mean that a person is necessarily a member of one of the groups listed in this definition.
4. **“Owned and Controlled”** means a business: (a) which is at least 51 percent owned by one or more “Socially and Economically Disadvantaged Individuals” or, in the case of a publicly-owned business, at least 51 percent of the stock of which is owned by one or more “Socially and Economically Disadvantaged Individuals”; and (b) whose management and daily business operations are controlled by one or more such individuals.
5. **“Manufacturer”** means a firm that operates or maintains a factory or establishment that produces on the premises the materials or supplies obtained by the CONTRACTOR.
6. **“Regular Dealer”** means a firm that owns, operates or maintains a store, warehouse, or other establishment in which the materials or supplies required for the performance of the Agreement are bought, kept in stock, and regularly sold to the public in the usual course of business. The firm must engage in, as its principal business, and in its own name, the purchase and sale of the product in question. A regular dealer in such bulk items as steel, cement, gravel, stone and petroleum products need not keep such products in stock if it owns or operates distribution equipment.
7. **“Fraud”** includes a firm that does not meet the eligibility criteria of being a certified DBE and attempts to participate in a U.S. DOT-assisted program as a DBE on the basis of false, fraudulent, or deceitful statements or representations, or under circumstances indicating a serious lack of business integrity or honesty. AUTHORITY may take enforcement action under 49 CFR, Part 31, Program Fraud and Civil

Remedies, against any participant in the DBE program whose conduct is subject to such action under 49 CFR, Part 31. AUTHORITY may refer cases of identified fraud to the Department of Justice, for prosecution under 18 U.S.C. 1001, or any other applicable provisions of law. Any person who makes a false or fraudulent statement in connection with participation of a DBE in any U.S. DOT-assisted program or otherwise, violates applicable Federal statutes.

8. ***“Other Socially and Economically Disadvantaged Individuals”*** means those individuals who are citizens of the United States (or lawfully admitted permanent residents), and who, on a case-by-case basis, are determined by Small Business Administration or AUTHORITY to meet the social and economic disadvantage criteria described below.

B. “Social Disadvantage”

1. The individual's social disadvantage must stem from his/her color, national origin, gender, physical handicap, long-term residence in an environment isolated from the mainstream of American society, or other similar cause beyond the individual's control.
2. The individual must demonstrate that he/she has personally suffered social disadvantage.
3. The individual's social disadvantage must be rooted in treatment which he/she has experienced in American society, not in other countries.
4. The individual's social disadvantage must be chronic, longstanding and substantial; not fleeting or insignificant.
5. The individual's social disadvantage must have negatively affected his/her entry into and/or advancement in the business world.
6. A determination of social disadvantage must be made before proceeding to make a determination of economic disadvantage.

C. “Economic Disadvantage”

1. The individual's ability to compete in the free enterprise system has been impaired due to diminished capital and credit opportunities, as compared to others in the same line of business and competitive market area that are not socially disadvantaged.
2. The following criteria will be considered when determining the degree of diminished credit and capital opportunities of a person claiming social and economic disadvantage:

With respect to the individual:

- availability of financing
- bonding capability
- availability of outside equity capital
- available markets

With respect to the individual and the business concern:

- personal and business assets
- personal and business net worth
- personal and business income and profits

IV. Submission of DBE Information and Ongoing Reporting Requirements (Post-Award)

If there is a DBE goal and/or DBE commitment on the Agreement, CONTRACTOR must complete and submit within the specified timelines, the following DBE documentation, electronically through e-mail or an AUTHORITY-approved electronic reporting system consistent with CONTRACTOR's DBE goal commitment:

- A. "Monthly DBE Subcontractor Commitment and Attainment Report Summary and Payment Verification" (Form 103)

The purpose of this form is to ensure CONTRACTOR DBE commitments are attained, properly reported, and credited in accordance with DBE crediting provisions based on the capacity the DBE performs the scope of work/service. This form further serves to collect DBE utilization data required under 49 CFR, Part 26.

The CONTRACTOR is required to complete and submit this form to AUTHORITY by the 10th of each month until completion of the Agreement. CONTRACTOR must submit first Form 103 following the first month of Agreement activity. Even if no DBE participation will be reported within a period, CONTRACTOR must execute and return the form.

The Form 103 must include the following information:

1. General Agreement Information – Including Agreement Number and Title, CONTRACTOR Name and the following:
 - a) Original Agreement Amount
 - b) Running Total of Change Order Amount
 - c) Current Agreement Amount
 - d) Amount Paid to CONTRACTOR during Month
 - e) Amount Paid to CONTRACTOR from Inception to Date
 - f) DBE Contract Goal
 - g) Total Dollar Amount of DBE Commitment
 - h) DBE Commitment as Percentage of Current Agreement Amount

2. Listed and Proposed CONTRACTOR/Subcontractor Information – For All DBE participation being claimed either race-neutrally or race-consciously, regardless of tier:

- a) DBE Firm Name, Address, Phone Number, DBE Capacity Type, Certification Type and Certification Number.
- b) DBE Firm Contract Value Information:
Original Contract Amount, running total of change order amount, Current Contract Amount, Amount Paid to CONTRACTOR or Subcontractor(s) During Month and Amount Paid to CONTRACTOR or Subcontractor(s) to date.

CONTRACTOR is advised not to report the participation of DBE(s) toward the CONTRACTOR's DBE attainment until the amount being claimed has been paid to the DBE.

3. CONTRACTOR Assurance of Full Compliance with Prompt Payment Provisions

CONTRACTOR must sign the prompt payment assurance statement of compliance contained within the Monthly Form 103, providing assurance that timely payments have been issued to all subcontractors in accordance with regulatory mandates and as required by 49 CFR Part 26.29.

4. CONTRACTOR Payment Verification Summary

CONTRACTOR is to further maintain and submit a Verification of Payment Summary inclusive of a detailed running tally of related invoices submitted by DBE(s) and non-DBE(s), including dates of invoice submission, dates accepted and corresponding dates and amount of payment made. The Verification of Payment Summary must also include:

DBE(s) and non DBE(s) invoice number, invoice amount, invoice date, CONTRACTOR's invoice number that incorporated the corresponding DBE and non-DBE invoice(s) for billing purposes, date of invoice submission to AUTHORITY, date and amount AUTHORITY paid on CONTRACTOR's Invoice. The report must reflect a breakout of retention withheld (including retention as specified in subcontract agreement(s) and disputed invoice retention) and retention payments made, check number and date paid to DBEs and non-DBEs.

CONTRACTOR to submit a Verification of Payment Summary with the Monthly Form 103 submission for each DBE firm in which CONTRACTOR has reflected a value paid within the reporting period. Verification of Payment Summary must be signed by the applicable DBE and submitted with Form 103 to authenticate reported payments.

B. "Monthly DBE Trucking Verification" Form

Prior to the 10th of each month, CONTRACTOR must submit documentation on the "Monthly DBE Trucking Verification," Form to AUTHORITY showing the amount paid to DBE trucking companies. CONTRACTOR must also obtain and submit documentation to AUTHORITY showing the amount paid by DBE trucking companies to all firms, including owner-operators, for the leasing of trucks. If the DBE leases trucks from a non-DBE, CONTRACTOR may count only the fee or commission the DBE receives as a result of the lease arrangement.

CONTRACTOR must also obtain and submit documentation to AUTHORITY showing the truck number, owner's name, California Highway Patrol CA number, and if applicable, the DBE certification number of the owner of the truck for all trucks used during that month.

C. DBE Subcontract Agreements

CONTRACTOR must submit to AUTHORITY copies of executed subcontracts and/or purchase orders (PO) for all DBE firms participating on the contract within ten (10) working days of award. CONTRACTOR must immediately notify AUTHORITY in writing, of any problems it may have in obtaining the subcontract agreements from listed DBE firms within the specified time.

D. Semi-Annual Subcontractor Paid Report Summary

AUTHORITY will require CONTRACTOR (inclusive of DBE primes) to report payment data to lower-tiers on a semi-annual basis each year, using the "Semi-Annual Subcontractor Paid Report Summary." These reports will capture payments to CONTRACTOR and payments to non-DBEs within the respective reporting period. Reported payments to lower-tiers must include a signed payment verification form.

CONTRACTOR will adhere to the following submittal schedule:

- April 10th Report, reporting period: October 1st through March 31st
- October 10th Report, reporting period: April 1st through September 30th

E. Final Report-Utilization of Disadvantaged Business Enterprises (DBE)

Upon completion of the project, CONTRACTOR must complete and submit a "Final Report-Utilization of Disadvantaged Business Enterprises (DBE), Subcontractors," certified correct by CONTRACTOR or the CONTRACTOR's authorized representative, to facilitate reporting and capturing DBE attainments at conclusion of the project. The form must be furnished to AUTHORITY within thirty (30) days from the date of the project.

The amount of ten-thousand dollars (\$10,000) will be withheld from payment until a satisfactory form is submitted.

F. Disadvantaged Business Enterprises (DBE) Certification Status Change

If a DBE subcontractor is decertified during the life of the project, the decertified subcontractor must notify the CONTRACTOR in writing with the date of decertification. If a subcontractor becomes a certified DBE during the life of the project, the subcontractor must notify CONTRACTOR in writing with the date of certification (Attach DBE certification/decertification letter). CONTRACTOR must furnish the written documentation to AUTHORITY within ten (10) days of receipt. Upon completion of the project, the "Disadvantaged Business Enterprises (DBE) Certification Status Change" must be signed and certified correct by the CONTRACTOR indicating the DBEs' existing certification status. If there are no changes, indicate "No Changes." The signed and certified form must be furnished to AUTHORITY within thirty (30) days from the date of project acceptance.

Failure to submit any of the required submittals above and their support documentation within the specified timeline shall result in a penalty of ten dollars (\$10) per day, per submittal document.

AUTHORITY requires CONTRACTOR to maintain records and documents of payments to lower-tiers, including DBEs, for a period of four (4) years from the date of final payment by AUTHORITY, unless otherwise provided by applicable record retention requirements for CONTRACTOR's agreement, whichever is longer. These records will be made available for inspection upon request by any authorized representative of AUTHORITY. This reporting requirement extends to all lower-tiers, both DBE and non-DBE.

AUTHORITY reserves the right, at its sole discretion, to demonstrate responsiveness to requirements of CFR 49 Part 26.37 by implementing the following method(s):

- a) Posting contractor payment data to a website, database, or other place accessible to subcontractors to assist them in determining when they should expect to receive payment.
- b) Requiring CONTRACTOR to use an automated reporting system, inclusive of, but not limited to, real time entry of payments made and received by CONTRACTOR and their lower-tiers.

V. DBE Eligibility and Commercially Useful Function Standards

A DBE must be certified at the time of bid/proposal submission:

1. A DBE must be a small business firm defined pursuant to 13 CFR Part 121 and be certified through the California Unified Certification Program ("CUCP") at the time of

bid submission. A listing of DBEs certified by the CUCP is available at the following source:

The CUCP web site, which can be accessed at <http://www.dot.ca.gov/hq/bep>.

2. A DBE may participate as a prime contractor, subcontractor, joint venture partner, vendor of material or supplies, or as a trucking company.
3. A DBE joint venture partner must be responsible for specific contract items of work, or clearly defined portions thereof. Responsibility means actually performing, managing, and supervising the work with its own work forces. The DBE joint venture partner must share in the capital contribution, control, management, risks, and profits of the joint venture commensurate with its ownership interest.
4. The use of joint-checks for DBE firms must be approved by AUTHORITY prior to execution, and a joint-check agreement must accompany the request to AUTHORITY.
5. A DBE must perform a commercially useful function in accordance with 49 CFR Part 26.55 (i.e. must be responsible for the execution of a distinct element of the work, and must carry out its responsibility by actually performing, managing, and supervising the work). A DBE should perform at least thirty percent (30%) of the total cost of its contract with its own workforce to presume it is performing a commercially useful function.

VI. DBE Crediting Provisions

- A. When a DBE is proposed to participate in the Agreement, at any tier, only the value of the work proposed to be performed by the DBE with its own work force may be counted towards DBE participation. If CONTRACTOR is a DBE joint venture participant, only the DBE proportionate interest in the joint venture must be counted.
 1. If a DBE intends to subcontract part of the work of its subcontract to a lower-tier subcontractor, the value of the subcontracted work may be counted toward DBE participation only if the subcontractor is a certified DBE and performs the work with their own forces. Services subcontracted to a non-DBE firm may not be credited toward the CONTRACTOR's DBE attainment.
 2. CONTRACTOR is to calculate and credit participation by eligible DBE vendors of equipment, materials, and supplies toward DBE attainment as follows:
 - a) Sixty percent (60%) of expenditures for equipment, materials, and supplies required under the Agreement obtained from a regular dealer; or

- b) One hundred percent (100%) of expenditures for equipment, materials, and supplies required under the Agreement obtained from a DBE manufacturer.
3. The following types of fees or commissions paid to DBE Subcontractors, Brokers, and Packagers may be credited toward CONTRACTOR's DBE attainment, provided that the fee or commission is reasonable and not excessive, as compared with fees or commissions customarily allowed for similar work including:
- a) Fees and commissions charged for providing bona fide professional or technical services, or procurement of essential personnel, facilities, equipment, materials, or supplies required in the performance of the Agreement;
 - b) Fees charged for delivery of material and supplies (excluding the cost of materials or supplies themselves), when the licensed hauler, trucker, or delivery service is not also the manufacturer of, or a regular dealer in, the material and supplies;
 - c) Fees and commissions charged for providing any insurance specifically required in the performance of the Agreement.
4. CONTRACTOR may count the participation of DBE trucking companies toward DBE attainment, as follows:
- a) The DBE must be responsible for the management and supervision of the entire trucking operation for which it is responsible on a particular contract.
 - b) The DBE must itself own and operate at least one fully licensed, insured, and operational truck used on the contract.
 - c) The DBE receives credit for the total value of the transportation services it provides on the contract using trucks it owns, insures, and operates using drivers it employs.
 - d) The DBE may lease trucks from another DBE firm, including an owner-operator who is certified as a DBE. The DBE who leases trucks from another DBE receives credit for the total value of the transportation services the lessee DBE provides on the contract.
 - e) The DBE may also lease trucks from a non-DBE firm, including an owner-operator. The DBE who leases trucks equipped with drivers from a non-DBE is entitled to credit for the total value of transportation services provided by non-DBE leased trucks equipped with drivers not to exceed the value of transportation services on the contract provided by the DBE-owned trucks or leased trucks with DBE drivers. Additional participation by non-DBE owned trucks equipped with drivers receives credit only for the fee or commission it receives as a result of the lease arrangement.
 - f) The DBE may lease trucks without drivers from a non-DBE truck leasing company and if the DBE uses its own employees as drivers, it is entitled to credit for the total value of these hauling services.

For purposes of this paragraph, a lease must indicate that the DBE has exclusive use of and control over the truck. This does not preclude the leased truck from working for others during the term of the lease with the consent of the DBE, so long as the lease gives the DBE absolute priority for use of the leased truck. Leased trucks must display the name and identification number of the DBE.

5. If the CONTRACTOR listed a non-certified, 1st tier Subcontractor to perform work on this Agreement, and the non-certified Subcontractor subcontracts a part of its work or purchases materials and/or supplies from a lower tier DBE certified Subcontractor or Vendor, the value of work performed by the lower tier DBE firm's own forces can be counted toward DBE participation on the Agreement. If a DBE contractor performs the installation of purchased materials and supplies, they are eligible for full credit of the cost of the materials.
6. CONTRACTOR is advised not to report the participation of DBE(s) toward the CONTRACTOR's DBE attainment until the amount being claimed has been paid to the DBE.

VII. DBE Substitution, Termination and On-Going Good Faith Efforts

AUTHORITY requires that CONTRACTOR not terminate a DBE without AUTHORITY's prior written consent. This includes, but is not limited to, instances in which CONTRACTOR seeks to perform work originally designated for a DBE with its own work force or those of an affiliate, a non-DBE firm, or with another DBE firm.

AUTHORITY will provide such written consent only if it agrees, for reasons stated in the concurrence document, that CONTRACTOR has good cause to terminate the DBE firm. For purposes of this section, good cause includes the following circumstances:

- A. The listed DBE subcontractor fails or refuses to execute a written contract;
- B. The listed DBE subcontractor fails or refuses to perform the work of its subcontract in a way consistent with normal industry standards. Provided, however, that good cause does not exist if the failure or refusal of the DBE subcontractor to perform its work on the subcontract results from the bad faith or discriminatory action of CONTRACTOR;
- C. The listed DBE subcontractor fails or refuses to meet CONTRACTOR's reasonable, nondiscriminatory bond requirements;
- D. The listed DBE subcontractor becomes bankrupt, insolvent, or exhibits credit unworthiness;

- E. The listed DBE subcontractor is ineligible to work on public works projects because of suspension and debarment proceedings pursuant 2 CFR Parts 108, 215 and 1,200 or applicable state law;
- F. CONTRACTOR has determined that the listed DBE subcontractor is not a responsible contractor;
- G. The listed DBE subcontractor voluntarily withdraws from the project and provides to you written notice of its withdrawal;
- H. The listed DBE is ineligible to receive DBE credit for the type of work required;
- I. A DBE owner dies or becomes disabled with the result that the listed DBE contractor is unable to complete its work on the contract;
- J. Other documented good cause that you determine compels the termination of the DBE. Provided, that good cause does not exist if CONTRACTOR seeks to terminate a DBE it relied upon to obtain the Agreement so that CONTRACTOR can self-perform the work for which the DBE contractor was engaged or so that CONTRACTOR can substitute another DBE or non-DBE contractor after Agreement award.

Before transmitting to AUTHORITY its request to terminate and/or substitute a DBE subcontractor, CONTRACTOR must give notice in writing to the DBE, with a copy to AUTHORITY, of its intent to request to terminate and/or substitute, and the reason for the request.

CONTRACTOR must give the DBE five (5) days to respond to CONTRACTOR's notice and advise AUTHORITY and CONTRACTOR of the reasons, if any, why it objects to the proposed termination of its subcontract or purchase order and why AUTHORITY should not approve CONTRACTOR's action. If required in a particular case as a matter of public necessity (e.g. safety), CONTRACTOR may provide a response period shorter than five (5) days.

In the event of an approved DBE substitution, termination, or failure of a DBE to complete its work on the contract for any reason, the DBE must be substituted with another DBE or adequate good faith efforts must be documented by CONTRACTOR within five (5) days, to the extent needed to meet the contract-specific DBE goal. Note: The five (5) day period may be extended for an additional five (5) days if necessary, at the request of the CONTRACTOR.

The substitute DBE must be certified as a DBE at the time of request for substitution. CONTRACTOR shall not be entitled to any payment for work or materials unless it is performed or supplied by the listed DBE, unless the DBE is terminated in accordance with this section and is approved by AUTHORITY.

Should CONTRACTOR elect to submit a good faith effort documentation in lieu of proposing additional DBE participation, AUTHORITY will review the documentation and provide a written

determination to CONTRACTOR stating whether or not good faith efforts have been adequately demonstrated.

The substitute DBE cannot work on the Agreement until its work eligibility has been confirmed and required subcontracts, supplies, trucking commitments, or other services have been approved by AUTHORITY.

VIII. Additional DBE Subcontractors

In the event CONTRACTOR identifies additional DBE Subcontractors or suppliers not previously identified by CONTRACTOR for DBE participation under the Agreement, CONTRACTOR must notify AUTHORITY by submitting "Request for Additional DBE Firm," to enable AUTHORITY to verify the firm's eligibility, capacity, CUF and ensure there is not a scope conflict with another listed firm. Proposed firms cannot be applied towards CONTRACTOR's DBE participation until approved by AUTHORITY.

CONTRACTOR must also submit, for each DBE identified after contract execution, a written confirmation from the DBE acknowledging that it is participating in the contract for a specific value, including the corresponding scope of work (a subcontract agreement can serve in lieu of the written confirmation).

IX. DBE "Frauds" and "Fronts"

Only legitimate DBEs are eligible to participate as DBEs in the AUTHORITY's U.S. DOT-assisted contracts. CONTRACTOR is cautioned against knowingly and willfully using "fronts." The use of "fronts" and "pass through" subcontracts to non-disadvantaged firms constitute criminal violations. Further, any indication of fraud, waste, abuse, or mismanagement of Federal funds should be immediately reported to the Office of Inspector General, U.S. Department of Transportation at the toll-free hotline: (800) 424-9071; or to the following: 245 Murray Drive, Building 410, Washington, DC 20223; Telephone: (202) 406-570.

X. Dispute Resolution

All contracts in excess of five-hundred thousand dollars (\$500,000) shall contain provisions or conditions which will allow for dispute resolution remedies in instances where contractors violate or breach DBE Program requirements, inclusive but not limited to, prompt payment and provide for such sanctions and penalties as may be appropriate.

CONTRACTOR shall incorporate this Section into each subcontract related to work arising under this Agreement and shall not incorporate by reference.

CONTRACTOR and subcontractor agree to notify AUTHORITY within five (5) business days of any prompt payment and/or DBE Program disputes which cannot be settled by discussions between the parties involved.

CONTRACTOR and subcontractor further agree to proceed through informal meetings, mediation, or any combination thereof as further detailed below. Dispute submittals shall include the method(s) of dispute resolution selected, terms, timeframes, and a detailed summary of assistance being requested (as applicable).

I. INFORMAL MEETINGS:

AUTHORITY is available to assist CONTRACTOR with coordination of informal meeting requests to assist in the resolution of disputes between CONTRACTOR and subcontractor. AUTHORITY's DBELO or a designated DBE support representative will conduct the informal meetings with parties in dispute. Representatives from CONTRACTOR and subcontractor for the purpose of dispute resolution, must include individuals authorized to bind each interested party. All parties must agree to the procedure.

II. Mediation

The parties to a contract may agree to endeavor to settle a dispute through informal mediation under independent third-party organizations. AUTHORITY's DBELO and her designated support staff is considered an independent third party. Submission to informal mediation is voluntary; it is not binding and offers advisory opinions.

Performance During Dispute: Unless otherwise directed by AUTHORITY, CONTRACTOR and its sub tiers shall continue performance under the Agreement while matters in dispute are being resolved.

Flow Down Requirements: The dispute resolution provisions flow down to all tiers.

These provisions shall not apply to disputes between CONTRACTOR and AUTHORITY. These provisions do not alter in any way or waive compliance with other provisions in the Agreement.

XI. Administrative Remedies and Enforcement

CONTRACTOR must fully comply with the DBE contract requirements, including the Authority's DBE Program and Title 49 CFR, Part 26 "Participation of Disadvantaged Businesses in Department of Transportation Financial Assistance Programs," and ensure that all subcontractors, regardless of tier, are also fully compliant. Failure by CONTRACTOR to carry out these requirements is a material breach of this Agreement, which may result in the termination of this Agreement, or such other remedy as AUTHORITY deems appropriate, which may include, but is not limited to:

1. Withholding monthly progress payments;
2. Assessing sanctions;

3. Liquidated damages; and/or
4. Disqualifying CONTRACTOR from future bidding/proposing as non-responsible.

In instances of identified non-compliance, a Cure Notice will be issued to CONTRACTOR identifying the DBE non-compliance matter(s) and specifying the required course of action for remedy.

CONTRACTOR must be given ten (10) working days from the date of the Cure Notice to remedy or to: (1) File a written appeal accompanied with supporting documentation; and/or (2) Request a hearing with AUTHORITY to reconsider AUTHORITY's DBE determination.

Failure to respond within the ten (10) working day period will constitute a waiver of CONTRACTOR's right to appeal. If CONTRACTOR files an appeal, AUTHORITY, must issue a written determination and/or set a hearing date within ten (10) working days of receipt of the written appeal, as applicable. A final Determination will be issued within ten (10) working days after the hearing, as applicable.

If after review of CONTRACTOR's appeal, AUTHORITY decides to uphold the decision to impose DBE administrative remedies on CONTRACTOR, the written determination must state the specific remedy(ies) to be imposed.

Failure to comply with the Cure Notice and/or to remedy the identified DBE non-compliance matter(s) is a material breach of the Agreement and is subject to administrative remedies including withholding at a minimum of two percent (2%) of the invoice amount due per month for every month that the identified non-compliance matter(s) is not remedied. Upon satisfactory compliance, AUTHORITY will release all withholdings.

In addition to administrative remedies defined in this section, AUTHORITY is not precluded from invoking other contractual and/or legal remedies available under federal, state or local laws.

SECTION VII: GENERAL PROVISIONS - EXHIBIT A

SECTION VII: GENERAL PROVISIONS

A. COST BREAKDOWN

Within fifteen (15) calendar days after "Notice to Proceed," the Contractor shall, upon request by the Authority, submit a cost breakdown of the lump sum Bid entered on the Bid Form for all construction work. This cost breakdown will form the basis for progress payments in accordance with these Specifications and shall show all of the major categories and subcategories of work and equipment requested by the Authority. Additionally, all costs shall be segregated between off-site and on-site costs. Mobilization costs shall not exceed ten percent (10%) of total construction costs. Bonds and insurance costs will be identified as a separate line item. Such cost breakdown shall not be required if the Authority, at its sole discretion, elects to pay the Contractor in lump sum within thirty (30) calendar days of receipt of proper invoice following the Contractor's satisfactory completion and the Authority's acceptance of all work.

B. PROGRESS PAYMENTS

1. The Authority, no later than the twenty-fifth (25th) day of each month, shall prepare a progress payment estimate based on the estimated percentage of completion of each Bid Item and on the Contractor's actually incurred allowable expenses on such Bid Items. The Authority will issue the progress payment, in the amount it deems appropriate, by approximately the fifteenth (15th) day of the following month.
2. For purposes of calculating the progress payments, Authority will use the cost breakdown submitted by the Contractor for each Bid Item at the start of this Agreement. In no event will the Authority make a progress payment that, when added to the prior progress payments, amounts to a sum more than the Contractor's actual aggregate incurred expenses, adjusted to include Contractor's overhead and profit as allocated to such incurred expenses.
3. The Authority will pay only ninety-five percent (95%) of each progress payment amount as determined above, retaining five percent (5%) as part security for the fulfillment of this Agreement by the Contractor, subject to Public Contract Code 22300.
4. The amount retained in accordance with paragraph B.3., hereinabove from the progress payments will be paid in full to the Contractor as part of the final payment upon Contractor's full completion of this Agreement, except that one half of one percent ($\frac{1}{2}$ of 1%) of this Agreement's total price shall be retained for one (1) year beyond the date of the Notice of Completion filed for this Agreement as partial security for fulfillment of the warranty obligations by the Contractor under this Agreement.
5. No progress payments will be made for materials not installed.

6. Progress payments made by Authority in no way shall be deemed or construed as acceptance by the Authority of work or waiver by the Authority of any rights hereunder.
7. The Contractor shall pay subcontractors, promptly upon receipt of each Authority progress payment; the respective amounts allowed the Contractor on account of the work performed by subcontractors, to the extent of each such subcontractor's interest therein. Such payments to subcontractors shall be based on estimates made pursuant to this Agreement. Any diversion by the Contractor of payments received for prosecution of a contract, or failure to reasonably account for the application or use of such payments, constitutes ground for termination of the Contractor's control over the work and for taking over the work, in addition to disciplinary action by the Contractor's State License Board. The subcontractor shall notify, in writing, the Contractor's State License Board and the Authority of any payment less than the amount or percentage approved for the class or item of work as set forth in this Agreement.
8. In addition to other amounts properly withheld under this Agreement, the Authority shall withhold all legally required sums for, but not necessarily limited to, stop notices, labor and tax liens, etc.

C. FINAL INSPECTION AND ACCEPTANCE

Promptly after Substantial Completion has occurred, Contractor shall perform all Punch List Work, if any, which was deferred for purposes of Project Completion, and shall satisfy all of its other contractual obligations under the contract documents.

When the Contractor determines that the work is fully completed, including satisfactory completion of all inspections, tests, and required documentation, Punch List and clean-up items, Contractor shall give the Authority a written request for Final Acceptance within ten (10) days thereafter, specifying that the work is completed and the date on which it was completed.

Within thirty (30) days after receipt of the request for Final Acceptance from Contractor, Authority will make a final inspection of the work and will either:

1. Reject the request for Final Acceptance, specifying the defective or uncompleted work; or
2. Issue a written Final Acceptance and record Notice of Completion with County Recorder.

Substantial Completion is defined herein as; In the opinion of the Authority, that work or portion thereof that is sufficiently complete and in accordance with the Contract, that it can be utilized by the Authority for the purpose for which it was intended. A determination of Substantial Completion does not waive, but may not

require the prior completion of minor items, which do not impair the Authority's ability to safely occupy and utilize the Work for its intended purpose.

D. CLAIMS

A "Claim" that falls within the definition of Public Contract Code Section 9204 (hereafter, "Section 9204"), as may be amended, means a separate demand by Contractor, sent by registered mail or certified mail with return receipt requested, for one or more of the following: (a) a time extension, including, without limitation, for relief from damages or penalties for delay assessed by Authority; (b) payment by Authority of money or damages arising from work done by, or on behalf of, the Contractor and payment for which is not otherwise expressly provided or to which Contractor is not otherwise entitled; and/or (c) payment of an amount that is disputed by the Authority.

It is important that the Authority be promptly notified of any potential claims so that it can timely and reasonably investigate the merits of the Claim when the events giving rise to the Claim are current and, when appropriate, make timely adjustments in the work in response thereto. Contractor shall submit to Authority a Notice of Claim within fifteen (15) calendar days after receipt of or the discovery of information, or the occurrence of an event, or any actions of Authority or its agents, that Contractor believes may result in a Claim. The Notice of Claim shall state the reason(s) for the Claim and the nature of the additional costs or delay that Contractor believes it will incur. Such Notice shall be submitted prior to the submission of the Claim documentation described below. If a Notice of Claim is not submitted within the fifteen (15) day period, it shall be deemed waived.

The Authority and Contractor agree to attempt to informally resolve any disputes which may give rise to a Claim. The Authority and Contractor shall meet within twenty (20) calendar days, or any mutually agreeable extension thereof, from the date the Notice of Claim is received by Authority in a good faith effort to resolve the dispute. Contractor shall provide a representative at the meeting who has authority to resolve the claim on the Contractor's behalf. If a resolution is not reached and the Authority and Contractor have not, in writing, mutually agreed to continue with informal efforts at resolution, Contractor shall file a Claim within thirty (30) calendar days after the informal resolution process has concluded, or such Claim shall be deemed waived.

The Authority and the Contractor shall process the Claim in accordance with Section 9204 and the requirements set forth herein.

1. Claim Requirements.

- a. Any submittal intended by the Contractor to be evaluated by Authority as a Claim shall be entitled "Claim" and sent to Authority by registered mail or certified mail with return receipt requested. The Contractor may present a Claim on behalf of a subcontractor or a lower tier subcontractor meeting the requirements of Section 9204(d)(5).

- b. All Claims shall be submitted by the Contractor within thirty (30) calendar days after the conclusion of the informal resolution process discussed above; however, this timeframe may be extended unilaterally by Authority in writing. Any Claim not submitted within the specified thirty (30) calendar days, or as otherwise authorized by Authority, shall be deemed untimely and waived.
- c. All Claims shall include reasonable documentation in support, including a detailed factual statement that sets forth names, dates, and specific events that took place. In addition, supporting documents shall include a detailed analysis of a request for a time extension, if applicable, and a detailed breakdown of a request for additional compensation. A revised construction schedule shall also be included identifying the impact of the delays, including proposals to minimize any of the impacts.
- d. Claims filed by the Contractor shall be in sufficient detail to enable the Authority to ascertain the basis and amount of said Claims. The Authority will consider and determine the Contractor's Claims, and it will be the responsibility of the Contractor to furnish within a reasonable time such further information and details as may be required by the Authority to determine the facts or contentions involved in its Claims. Failure to submit sufficient information and details will be cause for Authority to deny the Claim and/or find the Claim untimely and, therefore, waived. If the Claim is silent regarding entitlement to extra time, the Contractor shall be entitled to no extra time in connection with the Claim. If the Claim is silent regarding additional compensation, the Contractor shall be entitled to no additional compensation in connection with the Claim.
- e. No Claims shall be filed later than the date of final payment.
- f. All Claims and any amendments thereto shall include the fully executed certification set forth below. Any Claim submitted without a fully executed certification shall be rejected by Authority and returned to the Contractor.

Certificate

Under the penalty of law for perjury or falsification with specific reference to the California False Claims Act, Government Code Section 12650 et. Seq., the undersigned,

(Name)

(Title)

(Company)

herby certifies that the claim for the additional compensation and time, if any, made herein for the work on this Contract is a true statement of the actual cost incurred and time sough, and is fully documented and supported under the Contract between the parties

Dated: _____

Signature: _____

Subscribed and sworn before this _____ day of _____, 20
_____ .

Notary Public

My Commission Expires: _____

2. Claim Review

Within forty-five (45) calendar days of receipt of the Claim, or any extension thereof agreed upon by the Authority and the Contractor, the Authority will conduct a reasonable review of the Claim and provide the Contractor with a written statement identifying what portion of the Claim is disputed and what portion is undisputed. Payment of any undisputed portion of the Claim shall be made within sixty (60) calendar days after the Authority issues its written statement. If the Authority does not provide a written statement within the time specified, the Claim shall be deemed rejected.

3. Claim Settlement Conference

If the Contractor disputes the Authority's written statement or if the Claim is deemed rejected, the Contractor may demand in writing, by registered or certified

mail to the Authority, return receipt requested, an informal conference to meet and confer in an effort to settle the disputed portion of any Claim. Within thirty (30) calendar days of receipt of such written demand, the Authority shall schedule a meet and confer conference. Such conference shall be attended by an officer or principle of the Contractor who has the authority to resolve the Claim on the Contractors' behalf.

If any portion of the Claim remains in dispute after the conference, the Authority shall, within ten (10) business days of the conclusion of the conference, provide the Contractor with a written statement identifying any portion that remains in dispute and any portion that is undisputed. Payment of any undisputed portion shall be made within sixty (60) calendar days after the Authority issues its written statement.

Any remaining disputed portion shall be submitted to nonbinding mediation, unless the Contractor and Authority waive the mediation upon mutual written agreement. Mediation includes any nonbinding process, including, but not limited to, a neutral evaluation or a dispute review board, in which an independent third party or board assists the parties in dispute resolution through negotiation or by issuance of an evaluation. The Authority and the Contractor will share in the costs of mediation equally in accordance with Section 9204.

Within ten (10) business days after issuance of the Authority's written statement, the Authority and Contractor shall select a mutually-agreeable mediator. If the parties cannot agree to a mediator, the Authority and Contractor will each select a mediator who will then select a qualified neutral third party to mediate with regard to the disputed portion of the Claim. Authority and Contractor will each bear its own fees and costs for its respective mediator in connection with the selection of the neutral mediator.

Claims which are not resolved through this Claims settlement process shall be resolved in accordance with the laws of the State of California.

E. FINAL PAYMENT

1. After the filing of the Notice of Completion, (or acceptance of the Project), the Authority will make a proposed final estimate, in writing, of the total amount payable to the Contractor, including therein an itemization of said amount, segregated as to Contract item quantities, extra work and any other basis for payment, and shall also show therein all deductions made or to be made for prior payments and amounts to be kept or retained under the provisions of the contract. All prior estimates and payments shall be subject to correction in the proposed final estimate. Within fifteen (15) days after proposed final estimate has been submitted, Contractor shall submit to the Authority written approval of proposed final estimate and/or a written statement of all claims of the Contract. No claim will be considered that was not included in written statement of claims, nor will any claim be allowed unless the Contractor has previously complied with the notice and protest requirements.

2. On the Contractor's approval, or if he files no claim within stated period, Authority will issue a final written estimate, in accordance with the proposed final estimate submitted to the Contractor; and thirty-five (35) days after the date of filing the Notice of Completion (or acceptance) Authority will pay the entire sum found to be due. Such final estimate and payment thereon shall be conclusive and binding against the Contractor on all questions relating to the amount of work done and the compensation payable therefore, except as otherwise provided.
3. If the Contractor within said period of fifteen (15) days files claims, Authority will issue a semi-final estimate in lieu of the final estimate submitted to the Contractor; and thirty-five (35) days after the date of filing of the Notice of Completion, the Authority will pay the sum found to be due. Such semi-final estimate and payment thereon shall be conclusive and binding against the Contractor on all questions relating to the amount of work done and the compensation payable therefore, except insofar as affected by the claims filed within the time and in the manner required hereunder and except as otherwise provided.
4. Upon final determination of any outstanding claims, the Authority shall then make and issue a final estimate in writing and within thirty (30) days thereafter, the Authority will pay the entire sum, if any, found due. Such final estimate shall be conclusive and binding against the Contractor on all questions relating to the amount of work done and the compensation payable therefore, except as otherwise provided.

F. EXTRA WORK AND CHANGES

1. New and unforeseen work, which in the judgment of the Authority is found necessary or desirable for the satisfactory completion of the work, will be classified as extra work, as well as work specifically designated as such in the plans or specifications. The Contractor shall do such extra work and furnish material and equipment therefore as directed by the Engineer in writing by a Contract Change Order. No extra work will be paid for or allowed unless the same was done upon written Contract Change Order of the Engineer and after all legal requirements have been complied with. The Contractor agrees that he will accept as full compensation for extra work, so ordered, an amount to be determined by one of the following methods:
 - a. A price mutually agreed upon in writing by the Engineer and Contractor (hereafter Agreed Price).
 - b. Force Account as hereafter provided.
2. It is mutually agreed that on the agreed price, the Contractor and subcontractor(s) shall add not more than a total markup of twenty percent (20%) to be divided between the Contractor and subcontractor(s) as full

- compensation for all other expenses including overhead, profit, bond, superintendence, insurance and small tools.
3. When extra work is to be paid for on a force account basis, compensation will be determined as follows:
- a. **Materials**

A sum equal to the actual cost to the Contractor of the materials furnished by him, as shown by paid receipts, plus not more than fifteen percent (15%). Only installed materials shall be paid for.
 - b. **Labor**
 - 1. The actual wages paid as shown on the certified copies of Contractor's payroll, for all labor directly engaged in the work and including the cost of any compensation insurance paid for by the Contractor, subsistence and travel allowance aid to such workmen as required by collective bargaining agreements plus not more than twenty percent (20%).
 - 2. To the actual wages as described in Subsection 1 above will be added a labor surcharge of not more than seventeen percent (17%), and shall constitute full compensation for all other payments, including payments imposed by State and Federal laws.
 - c. **Equipment**
 - 1. Equipment will be paid for as a rental charge whether owned by the Contractor or not, and said rental rates prevailing in the area for comparable equipment will be paid. To the direct costs of "Equipment Rental" will be added a not more than fifteen percent (15%) markup.
 - 2. All extra work at Force Account shall be adjusted daily upon report sheets prepared by the Engineer, furnished to the Contractor and signed by both parties. Said daily reports shall thereafter be considered the true record of all extra work done. The decision of the Engineer as to whether extra work has in fact been performed shall be conclusive and binding upon both parties to the contract.
4. A Contract Change Order approved by Authority may be issued to the Contractor at any time. Any such changes will be made using the Authority's Contract Change Order form, set forth in Exhibit H to the Contract. Should the Contractor disagree with any terms or conditions set forth in the Contract Change Order, the Contractor shall submit a written protest to the Authority within fifteen (15) days after the receipt of the Contract Change Order. The

protest shall state the points of disagreement and, if possible, the contract specification references, quantities and costs involved. If a written protest is not submitted within the above period, payment will be made as set forth in the approved Contract Change Order and such payment shall constitute full compensation for all work included therein or required thereby. Such unprotested approved Contract Change Orders will be considered as executed Contract Change Orders.

5. Contractor shall promptly notify the Authority in writing when it receives direction, instruction, interpretation or determination from any source other than the Authority or its designated representatives that may lead to or cause change in the work. Such written notification shall be given to the Authority before the Contractor acts on said direction, instruction, interpretation or determination.

G. EXTENDED FIELD OFFICE OVERHEAD COSTS

1. Within thirty (30) days after receipt of the Notice to Proceed, the Contractor shall submit a written statement to the Authority detailing its field office overhead costs which are time related. The Authority will review this cost submittal and reach a written agreement with the Contractor on a daily field office overhead cost rate which shall be issued as an agreed upon Change Order. The daily rate agreed to in this Change Order will be applicable throughout the duration of the Contract. No field office costs will be paid until such agreement is reached between the Authority and the Contractor and the Change Order concerning this daily rate is executed by both parties.
2. The individual cost components of the daily field office overhead rate shall represent costs which increase as a direct result of any time extension caused solely and exclusively by an act of the Authority. This listing may include such cost items as on-site project management, supervision, engineering and clerical salaries; on-site office utilities and rent; on-site company vehicles and their operating expenses; and site maintenance and security expenses. Field office overhead costs which are unaffected by increased time shall not be allowable costs in calculating the daily field office overhead rate. These non-time related costs include, but are not limited to, acquisition and installation of stationary equipment; temporary construction facilities; utilities and office furnishings (unless such items are rented or leased); the preparation of the site including clearing, grubbing, grading and fencing; mobilization and demobilization costs; and the costs of permits, bonds and insurance coverage for the project.
3. The individual wage cost components used to calculate the daily field office overhead rate shall be supported by actual employee payroll

records, not salary ranges or estimates. Hourly rates for management, supervisory, engineering and clerical employees shall be based upon 2,080 works hours per year and shall not include allowances for holidays, vacation or sick time.

4. The daily field office overhead rate shall be multiplied by the number of days the Contract is delayed or extended by Change Order and shall be added to the agreed upon Change Order cost. The days of delay shall be those caused solely by action of the Authority and documented by a time impact analysis prepared and submitted by the Contractor. In the event of a deductive Change Order is issued which reduces time under the Contract, the daily field office overhead rate shall be added to the deductive amount. No allowance for overhead costs and no profit allowance shall be added to the extended field office overhead cost.

H. ACCELERATION

1. Authority reserves the right to accelerate the work of the Contract at any time during its performance. In the event that the Authority directs acceleration, such directive will be given to the Contractor in writing. The Contractor shall keep cost and other Project records related to the acceleration directive separately from normal Project cost records and shall provide a written record of acceleration costs to the Authority on a daily basis.
2. In the event that the Contractor believes that some action or inaction on the part of the Authority constitutes an acceleration directive, the Contractor shall immediately notify the Authority in writing that the Contractor considers the actions or inactions an acceleration directive. This written notification shall detail the circumstances of the acceleration directive. The Contractor shall not accelerate their work efforts until the Authority responds to the written notification. If acceleration is then directed or required by the Authority, all cost records referred to in Subsection H.1 shall be maintained by the Contractor and provided to the Authority on a daily basis.
3. In order to recover additional costs due to acceleration, the Contractor must document that additional expenses were incurred and paid by the Contractor. Labor costs recoverable will only be overtime or shift premium costs or the cost of additional laborers brought to the site to accomplish the accelerated work effort. Equipment costs recoverable will only be the cost of added equipment mobilized to the site to accomplish the accelerated work effort.

I. VALUE ENGINEERING

Authority encourages the Contractor to submit Value Engineering Proposals (VEP's) whenever it identifies areas and/or instances in which improvements can be made, in order to avail the Authority of potential cost savings. Contractor and the Authority will share any savings in the manner described below.

A VEP applies to a Contractor developed and documented VEP that:

1. Requires a change to the contract.
2. Reduces the total contract price without impairing essential functions or characteristics of the work.
3. Results in an estimated total net savings to the Authority equal to or greater than \$1,000.

At a minimum, a VEP should include the following information:

1. A description of the existing contract requirements that are involved in the proposed change.
2. A description of the proposed change, and all specifications and/or plans necessary for the complete evaluation of the proposed change. Include a discussion of the differences between existing requirements and the proposed change, together with advantages and disadvantages of each changed item. All relevant back up documentation needs to be included to support proposed changes.
3. Cost estimate for existing contract requirements correlated to the Contractors lump sum breakdown and the proposed changes in those requirements, including costs of development and implementation by the Contractor.

Contractor shall submit the VEP to the Authority. At its sole discretion, Authority may accept, in whole or in part and by Change Order, any VEP submitted pursuant to this section. Until a Change Order is issued on a VEP, Contractor shall remain obligated to perform in accordance with the Contract. The decision of the Authority as to the rejection or acceptance of a VEP shall be at the sole discretion of the Authority.

If a VEP, submitted by the Contractor pursuant to this section is accepted by the Authority, the total Contract price shall be adjusted based upon a sharing of the net savings by the Contractor and the Authority (50% Authority, 50% Contractor). Contractor's profit shall not be reduced by application of the VEP.

Net savings are defined as gross savings less the Contractor's costs and less the Authority's costs.

1. Contractor's cost means reasonable costs incurred by the Contractor in preparing the VEP and making the change.
2. Authority's costs means reasonable costs incurred by the Authority for evaluating and implementing the VEP.
3. Contractor is not entitled to share in either concurrent, collateral or future

Contract savings. Collateral savings are those measurable net reductions in the Authority's costs of operation that result from the VEP. Concurrent savings cover the reductions in the cost of performance of other contracts.

Contractor shall include appropriate VEP provisions in all subcontracts greater than \$25,000.

J. STOP NOTICES

The Authority, at its sole discretion, may, at any time, retain out of any amounts due the Contractor, sums sufficient to cover claims filed pursuant to Section 9358 et seq. of the California Civil Code.

K. ORDER OF WORK

Contractor shall perform work hereunder at such places, and in such order or precedence, as may be determined necessary by the Engineer to expedite completion of the required work.

L. DAVIS-BACON LABOR PROVISIONS (2 CFR SECTION 5.5)

1. Prevailing Wages

Contractor shall comply with all applicable requirements of Division 2, Part 7, Chapter 1 of the California Labor Code. If this Agreement is funded, in whole or in part, by federal funds, Contractor shall comply with these Davis-Bacon Labor Provisions ("Labor Provisions") and all applicable federal requirements respecting prevailing wages, including, but not limited to, the Davis-Bacon Act, 40 U.S.C. Sections 3141-3144, and Sections 3146-3148, as supplemented by U.S. DOL regulations at 29 CFR part 5, "Labor Standards Provisions Applicable to Contracts Governing Federally Financed and Assisted Construction."

If there is a difference between the minimum wage rates predetermined by the Secretary of Labor and the wage rates determined by the Director of the Department of Industrial Relations (DIR) for similar classifications of labor, the Contractor and subcontractors shall not pay less than the higher wage rate. The DIR will not accept lower state wage rates not specifically included in the Federal minimum wage determination.

2. Minimum Wages

- a. All mechanics and laborers employed or working upon the site of the work will be paid unconditionally, and not less often than once a week and without subsequent deduction or rebate on any account, the full amount of wages and bona fide fringe benefits (Or cash equivalents thereof) due at time of payment computed at wage rates not less than those specified in the General Wage Determinations referenced in this section regardless of any contractual relationship which may be alleged to exist between the Contractor and such laborers and mechanics; and the wage determination

decision shall be posted by the Contractor at the site of the work in a prominent place where it can be easily seen by the workers. For the purpose of this clause, contributions made or cost reasonably anticipated under the Labor Code of the State of California on behalf of laborers or mechanics are considered wages paid by such Laborers or mechanics. Also for the purpose of this clause, regular contributions made or costs incurred for more than a weekly period under plans, funds or programs, but covering the particular weekly period, are deemed to be constructively made or incurred during such weekly period.

- b. Authority shall require that any class of laborers or mechanics, including helpers, apprentices and trainees, which is not listed in the General Wage Determinations and which is to be employed under this Contract, shall be classified conformably to such wage determinations. The Authority will approve an additional classification and wage rate and fringe benefits therefore only when the following criteria have been met: (1) the work to be performed by the classification requested is not performed by a classification in the wage determination; and (2) the classification is utilized in the area by the construction industry; and (3) the proposed wage rate, including any bona fide fringe benefits, bears a reasonable relationship to the wage rates contained in the wage determination. If the Contractor and the laborers and mechanics to be employed in the classification (if known), or their representatives, and the Authority agree on the classification and wage rate (including the amount designated for fringe benefits where appropriate), a report of the action taken shall be sent by the Authority to the Administrator of the Wage and Hour Division, U.S. Department of Labor. The Administrator will approve, modify, or disapprove every additional classification action within thirty (30) days from receipt and so advise the Authority or will notify the Authority within the thirty (30)-day period that additional time is necessary.
- c. In the event the Authority does not concur in the Contractor's proposed classification or reclassification of a particular class of laborers and mechanics (including apprentices and trainees) to be used, the question, accompanied by the recommendation of the Authority, shall be referred to the State Director of Industrial Relations for determination. The wage rate (including fringe benefits where appropriate) determined pursuant to this subsection shall be paid to all workers performing work in the classification under this Contract from the first day on which work is performed in the classification.
- d. Authority shall require, whenever the minimum wage rate prescribed in the Contract for a class of laborers or mechanics includes a fringe benefit which is not expressed as an hourly wage and the Contractor is obligated to pay a cash equivalent of such a fringe benefit, an hourly cash equivalent thereof to be established. In the event the interested parties cannot agree upon cash equivalent of the fringe benefit, the questions, accompanied by the

recommendation of the Authority, shall be referred to the State Director of Industrial Relations for determination.

- e. If the Contractor does not make payments to a trustee or other third person, the Contractor may consider as part of the wages of any laborer or mechanic the amount of costs reasonably anticipated in providing bona fide fringe benefits under a plan or program, provided that the Secretary of Labor has found, upon written request of Contractor, that the applicable standards of the Davis-Bacon Act have been met. The Secretary of Labor may require the Contractor to set aside in a separate account assets for the meeting of obligations under this plan or program.
 - f. All disputes concerning the payment of wages or the classification of workers under this Agreement shall be promptly reported to the Authority.
3. Deductions

Authority may deduct from each progress payment and the Final Payment the following:

- a. Any Authority or third-party claims or losses for which Contractor is responsible hereunder or any Liquidated Damages which have accrued as of the date of the application for payment;
- b. If a notice to stop payment is filed with Authority, due to the Contractor's failure to pay for labor or materials used in the work, money due for such labor or materials, plus the 25% prescribed by law, will be withheld from payment to the Contractor. In accordance with Section 9358 of the Civil Code, Authority may accept a bond by a corporate surety in lieu of withholding payment;
- c. Any sums expended by or owing to Authority as a result of Contractor's failure to maintain the as-built drawings;
- d. Any sums expended by Authority in performing any of the Contractor's obligations under the Contract which Contractor has failed to perform; and
- e. Any other sums which Authority is entitled to recover from Contractor under the terms of the Contract.

- f. The amount of the accrued payments or advances as many be considered necessary to pay laborers and mechanics, including apprentices, trainees, and helpers, employed by the Contractor or any subcontractor the full amount of wages required by the Contract. In the event of failure to pay any laborer or mechanic, including any apprentice, trainee, or helper, employed or working on the site of the work, all or part of the wages required by the Contract, the Authority may, after written notice to the Contractor, sponsor, applicant, or owner, take such action as may be necessary to cause the suspension of any further payment, advance, or guarantee of funds until such violations have ceased.

The failure by Authority to deduct any of these sums from a progress payment shall not constitute a waiver of Authority's right to such sums.

All amounts owing by Contractor to Authority under the Contract shall earn interest from the date on which such amount is owing at the lesser of (i) ten percent (10%) per annum or (ii) the maximum rate allowable under applicable Governmental Rules.

4. Payrolls and Basic Records

- a. Payrolls and basic records relating thereto will be maintained during the course of the work and preserved for a period of three (3) years thereafter for all laborers and mechanics working at the site of the work. Such records will contain the name, address and social security number of each such worker, the correct classification, hourly rates of wages paid (including rates of contributions or costs anticipated for bona fide fringe benefits or cash equivalents thereof of the types described in Section 1(b)(2)(B) of the Davis-Bacon Act), daily and weekly number of hours worked, deductions made and actual wages paid. Whenever the Secretary of Labor has found under 29 CFR 5.5(a)(1)(iv) that the wages of any laborer or mechanic include the amount of any costs reasonably anticipated in providing benefits under a plan or program described in Section 1(b)(2)(B) of the Davis-Bacon Act, the Contractor shall maintain records which show that the commitment to provide such benefits is enforceable, that the plan or program is financially responsible, and that the plan or program has been communicated in writing to the laborers or mechanics affected, and records which show the costs anticipated or the actual cost incurred in providing such benefits. Contractors employing apprentices or trainees under approved programs shall maintain written evidence of the registration of apprenticeship programs and certification of trainee programs, the registration of the apprentices and trainees, and the rations and wage rates prescribed in the applicable programs.
- b. Contractor will submit weekly a copy of all payrolls to the Authority as required in these "Labor Provisions." The copy shall be accompanied by a statement signed by the employer or its agent indicating that the payrolls

are correct and complete; that each laborer or mechanic (including helpers, apprentices, and trainees) have been paid the full weekly wages earned, without rebate, either directly or indirectly, and that no deductions have been made either directly or indirectly from the full wages earned, other than permissible deductions as set forth in 29 CFR part 3; that the wage rates contained therein are not less than those determined by the State Director of Industrial Relations and that the classifications as set forth for each laborer or mechanic conform to the work performed. A submission of the "Weekly Statement of Compliance," which is required under this Contract, shall satisfy this requirement. The prime Contractor shall be responsible for the submission of copies of payrolls of all subcontractors. The Contractor will make the records required under the labor standard clauses of the Contract available for the inspection by authorized representatives of the Authority, and will permit such representatives to interview employees during working hours on the job.

5. Apprentices and Trainees

- a. Apprentices: Apprentices will be permitted to work at less than the predetermined rate for the work they perform when they are employed and individually registered in a bona fide apprenticeship program as defined in Section 1777.5 of the Labor Code of the State of California. The allowable ratio of apprentices to journeymen in any craft classification shall not be greater than the ratio permitted to the Contractor as to his entire work force under the registered program. Any employee listed on a payroll at an apprentice wage rate who is not registered or otherwise employed as stated above, shall be paid the wage rate determined by the State Director of Industrial Relations for the classification of work he actually performed. The Contractor or subcontractor will be required to furnish to the Authority or the State Director of Industrial Relations written evidence of the registration of his program and apprentices as well as the appropriate ratios and wage rates (expressed in percentages of the journeyman's rate contained in the applicable wage determination).

- b. Trainees: Except as provided in 29 CFR Section 5.16, trainees will not be permitted to work at less than the predetermined rate for the work performed unless they are employed pursuant to or individually registered in a program which has received prior approval, evidenced by formal certification, by the U.S. Department of Labor, Employment and Training Administration, Bureau of Apprenticeship and Training. The ratio of trainees to journeymen shall not be greater than that permitted under the plan approved by the Bureau of Apprenticeship and Training. Every trainee must be paid at not less than the rate specified in the approved program for his level of progress, expressed as a percentage of the journeyman hourly rate specified in the applicable wage determination. Trainees shall

be paid fringe benefits in accordance with the provisions of the trainee program. If the trainee program does not mention fringe benefits, trainees shall be paid the full amount of fringe benefits listed on the wage determination unless the Administrator of the Wage-Hour Division determines that there is an apprenticeship program associated with the corresponding journeyman wage rate on the wage determination which provides for less than full fringe benefits for apprentices. Any employee listed on the payroll at a trainee rate who is not registered and participating in a training plan approved by the Employment and Training Administration shall be paid not less than the applicable wage rate determined by the Secretary of Labor for the classification of work he actually performed. The Contractor or subcontractor will be required to furnish the contracting officer or a representative of the Wage-Hour Division of the U.S. Department of Labor written evidence of the certification of his program, the registration of the trainees, and the ratios and wage rates prescribed in that program. In the event the Employment and Training Administration withdraws approval of a training program, the Contractor will no longer be permitted to utilize trainees at less than the applicable predetermined rate for the work performed until an acceptable program is approved.

- c. Equal Employment Opportunity: The utilization of apprentices, trainees, and journeymen under this part shall be in conformity with the equal employment opportunity requirements of Executive Order 11246, as amended, 29 CFR part 30, and 41 CFR part 60.

6. Compliance with Copeland Regulations (29 CFR part 3)

The Contractor shall comply with the Copeland "Anti-Kickback" Act (18 U.S.C. 874 and 40 U.S.C. 276c). The Contractor shall also comply with the Copeland Regulations (29 CFR part 3), which are herein incorporated by reference.

7. Contract Termination; Debarment

A breach of Subsections 1 through 6 above may be grounds for termination of the Contract, and for debarment as a contractor and subcontractor provided in 29 CFR Section 5.12.

8. Overtime Requirements

No Contractor or subcontractor contracting for any part of the contract work which may require or involve the employment of laborers or mechanics shall require or permit any laborer or mechanic in any work week in which he is employed on such work to work in excess of eight (8) hours a day or forty (40) hours in such work week unless such laborer or mechanic receives compensation at a rate not less than one and one-half times the basic rate

of pay for all hours worked in excess of eight (8) hours a day or forty (40) hours in such work week.

9. Violation; Liability for Unpaid Wages

Pursuant to Section 1775 of the Labor Code of the State of California, in the event that any workman employed on this public works project is paid less than the amount specified in the General Prevailing Wage Determinations or less than is required, relative to overtime, the Contractor and any subcontractor responsible therefore shall be liable to the affected workman for the unpaid wages. In addition, such Contractor and subcontractor shall be liable to the State of California or the Authority for liquidated damages. Such liquidated damages shall be computed with respect to each individual workman found to be underpaid and shall be in the amount of \$50 per calendar day that a workman was underpaid.

10. Withholding for Liquidated Damages

The Authority may withhold or cause to be withheld, from any monies payable on account of work performed by the Contractor or subcontractor, such sums as may administratively be determined to be necessary to satisfy any liabilities of such Contractor or subcontractor for liquidated damages as provided in this section.

11. Final Labor Summary

The Contractor and each subcontractor shall furnish to the Authority, upon the completion of the Contract, a summary of all employment, indicating for the completed project, the total hours worked and the total amount earned.

12. Final Certificate

Upon completion of the Contract, the Contractor shall submit to the Authority, with the voucher for a final payment for any work performed under the Contract, a certification concerning wages and classifications for laborers and mechanics, including apprentices and trainees employed on the project, in the following form:

The undersigned, Contractor on

(Contract No.)

hereby certifies that all laborers, mechanics, apprentices and trainees employed by the Contractor or by a subcontractor performing work under the contract on the project have been paid wages at rates not less than those required by the contract provisions, and that the work performed by each such laborer, mechanic, apprentice or trainee conformed to the classifications set forth in the contract or training program provisions applicable to the wage rate paid.

Signature and Title

13. Notice to the Authority of Labor Dispute

Whenever the Contractor has knowledge that any actual or potential labor dispute is delaying or threatens to delay the timely performance of this contract, the Contractor shall immediately give notice thereof, including all relevant information with respect thereto, to the Authority.

14. Disputes Clause

- a. Disputes arising out of these Labor Provisions will be resolved in accordance with the procedures set forth in 29 CFR parts 5, 6, and 7, including disputes between the Authority, the Contractor (or any of its subcontractors), the U.S. Department of Labor, or the employees or their representatives. All disputes concerning the payment of prevailing wage rates or classifications shall be promptly reported to the Authority for its referral to DOT for decision or, at the option of the Authority, DOT referral to the Secretary of Labor. The decision of DOT or the Secretary of Labor, as the case may be, shall be final.
- b. All questions relating to the application or interpretation of the Copeland Act, the Contract Work Hours Standards Act, the Davis-Bacon Act, or Section 13 of the Act shall be sent to the Federal Transit Administration (FTA) for referral to the Secretary of Labor for

ruling or interpretation, and such ruling or interpretation shall be final.

15. Compliance with Davis-Bacon and Related Act requirements

All rulings and interpretations of the Davis-Bacon and Related Acts contained in 29 CFR parts 1, 3, and 5 are herein incorporated by reference.

16. Certification of Eligibility

By entering into this Agreement, the Contractor certifies that neither it (nor he or she) nor any person or firm who has an interest in the Contractor's firm is a person or firm ineligible to be awarded government contracts by virtue of Section 3(a) of the Davis-Bacon Act or 29 CFR 5.12(a)(1). No part of this Contract shall be subcontracted to any person or firm ineligible for award of a government contract by virtue of Section 3(a) of the Davis-Bacon Act or 29 CFR 5.12(a)(1). The penalty for making false statements is prescribed in the U.S. Criminal Code, 18 U.S.C. Section 1001.

17. Insertion in Subcontracts

The Contractor shall set forth in all subcontracts Subsections 1 through 16 above so that all of the provisions of this section will be inserted in all construction subcontracts of any tier, and such other clauses as the Government may by appropriate instructions require.

18. Certified Payroll Records

- a. The Authority shall obtain from the Contractor and each subcontractor a certified copy of each weekly payroll within seven (7) days after the regular payroll date. Following a review by the Authority for compliance with State and Federal labor laws, the payroll copy shall be retained at the project site for later review by FTA.
- b. Contractor may use the Department of Labor Form WH-347, "Optional Payroll Form," which provides for all the necessary payroll information and certifications.
- c. If, on or before the twentieth (20th) of the month, the Contractor has not submitted satisfactory payrolls covering its work and the work of all subcontractors for all payroll periods ending on or before the sixty (6th) of that month, such payrolls will be considered to be delinquent. Regardless of the number of delinquent payrolls, an amount equal to ten percent (10%) (but not less than \$1,000 or more than \$10,000) shall be deducted from the estimate. Deductions will be made separately for each estimate period in which a new delinquency appears and will be continued until payrolls have been submitted.

- d. Contractors employing apprentices or trainees under approved programs shall include a notation on the first weekly certified payrolls submitted to the Authority that their employment is pursuant to an approved program and shall identify the program.

M. TIME EXTENSION/DELAYS

- a. Contractor may be granted an extension of time for any portion of a delay in completion of the work due to acts of God, the public enemy, wars, civil unrest, fires, quarantine restrictions, or weather more severe than normal, providing that (1) the aforesaid causes were not foreseeable and did not result from an act or omission by the Contractor, (2) Contractor has taken reasonable precautions to prevent further delays owing to such causes, and (3) Contractor notifies Authority in writing of the cause(s) for the delay within ten (10) days from the beginning of any such delay. No claims for additional compensation or damages for the foregoing delays shall be allowed to the Contractor, and the extension of time provided for herein shall be the sole remedy of the Contractor on account of any such delays.
- b. An extension of time will not be granted for a delay described in the above paragraph(s) caused by a shortage of materials, except if materials are furnished by Authority, unless the Contractor supplies the Authority with documented proof that every effort to obtain the materials from all known sources that (a) such materials could have been obtained only at exorbitant prices or (b) the prices were entirely inconsistent with current rates, taking into account the quantities; and (c) such facts could not have been known or anticipated at the time the Notice To Proceed was issued. Contractor shall also submit proof, that the inability to obtain such materials when originally planned, did in fact, cause a delay in completion of the work that could not be compensated for by revising the sequence of its operations. Only the physical shortage of material will be considered as a basis for an extension of time.
- c. An extension of time for weather more severe than normal shall be granted only to the extent the work is actually delayed as determined by the Authority. Normal is defined as the monthly average of the temperature and rainfall wherein the work was performed for the prior twenty (20) years before the execution of the Contract.
- d. In the event Contractor is actually and necessarily delayed by an act or omission on the part of the Authority, as determined by the Authority, the Contractor shall notify the Authority in writing within five (5) days from the beginning of any such delay. The time for completion of the work may be extended at the sole discretion of the Authority.
- e. Within thirty (30) days after the last day of delay, Contractor shall provide Authority with detailed information concerning the circumstances of the

delay, the number of days actually delayed, and the measures taken to minimize or prevent the delay. Failure to submit information shall be sufficient reason to deny the claim. Authority shall ascertain the facts and the extent of the delay; and provide the Contractor its written findings, which will be final and conclusive. Except for the additional compensation for herein and except as provided in Public Contract Code Section 7102, Contractor shall have no claim for damages or compensation for any delay or hindrance.

- f. No extension of time will be granted for any Authority caused delay or delay as defined in which (a) the performance of work would have been concurrently delayed by Contractor induced causes, including but not limited to an act or omission of the Contractor, or (b) remedies are included or excluded by any other Contract provision. Only the actual delay necessarily resulting from the causes specified in this Article shall be grounds for extension of time. Should the Contractor be delayed at any time for any period by two or more of the causes specified in this article, Contractor shall only be entitled to one time extension for the entire delay.
- g. Any time extension granted to Contractor shall not release the Contractor or surety from its obligations. Work shall continue and be carried on in accordance with the Contract provisions, unless formally suspended or terminated by the Authority.

N. AFFIRMATIVE ACTION

If this Agreement is funded in whole, or in part, by federal funds, Contractor and subcontractors holding a value of work of \$10,000 or more must submit a Monthly Employment Utilization Report (Form 257) to the Authority Engineer by the fifth (5th) of each month or sanctions shall be applied for late submittal, non-submittal and incomplete forms returned to the Contractor and resubmitted after the due date.

The reporting period shall be for each calendar month.

The report shall include the information requested for each Contractor's aggregate work force (for all workers on all projects within Orange County) and not just for workers on this project.

If the form is not received by the fifth (5th) of the month, a deduction of ten (10%) (with a minimum of \$1,000 and a maximum of \$10,000) will be withheld from the monthly estimate at the option of the Authority.

The Contractor shall designate an Equal Employment Officer for the project and notify the Authority in writing whom that person is prior to beginning of work. All workers shall also be informed who the EEO Officer is.

O. STANDARD FEDERAL EQUAL EMPLOYMENT OPPORTUNITY CONSTRUCTION CONTRACT SPECIFICATIONS (EXECUTIVE ORDER 11246)

If this Agreement is funded in whole, or in part, by federal funds, Contractor and subcontractors holding a value of work of \$10,000 or more shall comply with the Standard Federal Equal Employment Opportunity Construction Contract Specifications, set forth in 41 CFR Section 60-4.3, which are incorporated herein by this reference.

P. CONFLICT OF INTEREST

All Contractors responding to this Invitation for Bids must avoid organizational conflicts of interest which would restrict full and open competition in this procurement. An organizational conflict of interest means that due to other activities, relationships or contracts, a Contractor is unable, or potentially unable to render impartial assistance or advice to the Authority; a Contractor's objectivity in performing the work identified in the specifications is or might be otherwise impaired; or a Contractor has an unfair competitive advantage. Contractor is obligated to fully disclose to the Authority in writing any conflict of interest issues as soon as they are known. All disclosures must be disclosed at the time of bid submittal.

Q. CODE OF CONDUCT

Contractor agrees to comply with the Authority's Code of Conduct as it related to Third-Party contracts, which is hereby referenced and by this reference is incorporated herein. Contractor agrees to include these requirements in all of it's subcontracts.

R. GOVERNMENT INSPECTIONS

The Authority and Federal Government representatives shall have access to the construction site and shall have the right to inspect all project works.

S. LICENSING, PERMITS AND INSPECTION COSTS

1. The Contractor warrants that it has all necessary licenses and permits required by the laws of the United States, State of California, the County of Orange, the Local Jurisdictions, and all other appropriate governmental agencies, and agrees to maintains these licenses and permits in effect for the duration of the Agreement. Further, Contractor warrants that its employees, agents, and Contractors and subcontractors shall conduct themselves in compliance with such laws and licensure requirements including, without limitation, compliance with laws applicable to nondiscrimination, sexual harassment and ethical behavior throughout the duration of this Agreement. Contractor further warrants that it shall not retain or employ an unlicensed subcontractor to perform work on this Project. Contractor shall notify the Authority immediately and in writing of its employees', agents', Contractors' or subcontractors'

inability to obtain or maintain, irrespective of the pendency of any appeal, any such licenses, permits, approvals, certificates, waivers, and exemptions. Such inability shall be cause for termination of this Agreement.

2. Contractor shall procure all permits and licenses; pay all charges, assessments and fees, as may be required by the ordinances and regulations of the public agencies having jurisdiction over the areas in which the work is located, and shall comply with all the terms and conditions thereof and with all lawful orders and regulations of each such public agency relating to construction operations under the jurisdiction of such agency.

T. HAZARDOUS SUBSTANCES

1. CAL-OSHA Requirements

All flammable, corrosive, toxic, or reactive materials being bid must have a complete CAL-OSHA Safety Data Sheet (SDS) accompanying the submitted bid.

2. South Coast Air Quality Management District (SCAQMD)

All materials (paints, coatings, inks, solvents, and adhesives) shall comply with the volatile organic compounds (VOC) content requirements of the applicable SCAQMD rules.

3. Notice of Hazardous Substances

Title 8, California Code of Regulations, Section 5194 (e) (c), states that the employer must inform any Contractor employers with employees working in the employer's workplace of the hazardous substances to which their employees may be exposed while performing their work. In compliance with this requirement, the Authority hereby gives notice to all bidders that the following general categories of hazardous substances are present on the Authority's premises:

- Adhesives, sealant, patching, and coating products
- Antifreezes, coolants
- Cleaners, detergents
- Paints, thinners, solvents
- Pesticides, Petroleum products (diesel and unleaded fuel, oil products)
- Printing, photocopying materials
- Propane Welding materials/compressed gases (e.g., acetylene, oxygen, nitrogen)

More specific information may be obtained from the Authority's Safety and Benefits office at (714) 560-5854, and from Safety Data Sheets (SDS) for individual products.

4. Hazardous Waste Labels

Containers containing hazardous substances must be labeled with the following information:

- Identity of hazardous substance-chemical name, not manufacturer or trade name;
- Appropriate health warning relative to health and physical hazard; and
- Name and address of manufacturer or other responsible party.

All containers containing hazardous substances may be rejected unless containers are properly labeled. Containers of 55 gallons or larger must have either weather resistant labels or the information should be painted directly on the containers.

U. CHANGES IN LAWS AND REGULATIONS

CONTRACTOR shall at all times comply with all applicable state and local regulations, policies, procedures and directives, including without limitation those listed directly or by reference in this Agreement. CONTRACTOR's failure to so comply shall constitute a material breach of Contract.

V. MEDIA AND THE PUBLIC

Contractor shall immediately refer all inquires from the news media or other public sources to the Authority's Project Manager, or designated representative, relating to this project.

W. COORDINATION AND ACCESS

Authority may undertake or award other contracts for additional work at the project site. Contractor is responsible for coordinating its work with the work of other Contractors as appropriate. The Contractor acknowledges that they do not have any exclusive access to the site or other work areas Authority may require that certain facilities and areas be used concurrently by the Contractors and others. Contractor shall cooperate fully with Authority Contractors/consultants that may be performing work in the construction area.

X. UTILITIES RELATED DELAYS

If, due to interruptions caused by the undocumented utilities, Contractor sustains loss which could not have been avoided by the judicious handling of forces, equipment and plant, there shall be paid to the Contractor that amount that the Authority may find to be a fair and reasonable compensation for the part of the Contractor's actual loss, that, in the opinion of Authority was unavoidable, determined as follow: Compensation for idle time of equipment will be determined in the same manner as determinations are made for equipment used in the performance of extra work paid for on a force account basis, as provided in Section F. Extra Work and Changes, Item 3,c. Equipment with the following exceptions:

1. The utility related delay factor for each classification of equipment shown in the Department of Transportation publication entitled Labor Surcharge And Equipment Rental Rates will be applied to that equipment rental rate.
2. The time for which the compensation will be paid will be the actual normal working time during which the delay condition exists, but in no case will exceed eight (8) hours in any one day.
3. The days for which compensation will be paid will be the calendar days, excluding Saturdays, Sundays and legal holidays, during the existence of the delay, except that when the rented equipment can be returned or used elsewhere on the project, then no payment will be made for utilities related delays.

Actual loss shall be understood to include no items of expense other than idle time of equipment and necessary payments for idle time of workers, and cost of extra moving of equipment. Compensation for idle time of equipment will be determined as provided in this section and compensation for idle time of workers will be determined as provided in Section F. Extra Work and Changes, Item 3, b. "Labor," and no markup will be added in either case for overhead and profit. The cost of extra moving of equipment will be paid for as extra work and changes as provided in Section F of General Provisions.

If performance of the Contractor's work is delayed as the result of the Utilities Related Delays, an extension of time determined pursuant to the provisions in Article 18. Termination for Default – Damages for Delay – Time Extensions will be granted.

Y. UTILITIES AND SUBSURFACE STRUCTURES

Contractor shall protect from damage utility and other subsurface structures that are to remain in place, be installed, relocated or otherwise rearranged (as used herein, rearranged includes installation, relocation, alteration or removal).

The right is reserved to the Authority, or their authorized agents, to enter upon the site for the purpose of making those changes that are necessary for the rearrangement of their facilities or for making necessary connections or repairs to their properties. Contractor shall cooperate with forces engaged in this work and shall conduct operations in such a manner as to avoid any unnecessary delay or hindrance to the work being performed by the other forces. Wherever necessary, the work of Contractor shall be coordinated with the rearrangement of utility or other non-highway facilities, and Contractor shall make arrangements with the owner of those facilities for the coordination of the work.

Attention is directed to the possible existence of underground main or trunk line facilities not indicated on the plans or in the special provisions and to the possibility that underground main or trunk lines may be in a location different from that which is indicated on the plans or in the special provisions. Contractor shall ascertain

the exact location of underground main or trunk lines whose presence is indicated on the plans or in the special provisions, the location of their service laterals or other appurtenances, and of existing service lateral or appurtenances of any other underground facilities which can be inferred from the presence of visible facilities such as buildings, meters and junction boxes prior to doing work that may damage any of the facilities or interfere with their service.

If Contractor cannot locate an underground facility whose presence is indicated on the plans or in the special provisions, the Contractor shall so notify the Authority in writing. If the facility for which the notice is given is in a substantially different location from that indicated on the plans or in the special provisions, the additional cost of locating the facility will be paid for as extra work as provided in Section F.

If Contractor discovers underground main, trunk lines or other structures and utilities not indicated on the plans or in the special provisions, Contractor shall immediately give the Authority and the Utility Company written notification of the existence of those facilities. Such facilities shall be located and protected from damage as directed by the Authority, and the cost of that work will be paid for as extra work as provided in Section F. Contractor shall, if directed by the Authority repair any damage which may occur to the main or trunk lines. The cost of that repair work, not due to the failure of the Contractor to exercise reasonable care, will be paid for as extra work as provided in Section F. Damage due to Contractor's failure to exercise reasonable care shall be repaired at the Contractor's cost and expense.

Where it is determined by the Authority that the rearrangement of an underground facility is essential in order to accommodate the project work and the plans and specifications do not provide that the facility is to be rearranged, Authority will provide for the rearrangement of the facility by other forces or the rearrangement shall be performed by Contractor and will be paid for as extra work as provided in Section F.

When ordered by the Authority in writing, Contractor shall rearrange any utility or other subsurface structures necessary to be rearranged as a part of the project work and that work will be paid for as extra work as provided in Section F.

Should Contractor desire to have any rearrangement made in any utility facility, or other improvement, for the Contractor's convenience in order to facilitate the Contractor's construction operations, which rearrangement is in addition to, or different from, the rearrangements indicated on the plans or in the special provisions, the Contractor shall make whatever arrangements are necessary with the owners of the utility or other subsurface structure for the rearrangement and bear all expenses in connection therewith.

Contractor shall immediately notify the Authority of any delays to the Contractor's operations as a direct result of underground utilities or other structures which were not indicated on the plans or in the special provisions or were located in a position substantially different from that indicated on the plans or in the special provisions,

(other than delays in connection with rearrangements made to facilitate the Contractor's construction operations or delays due to a strike or labor dispute). These delays will be considered utilities related delays within the meaning of Section X. Utilities Related Delays and compensation for the delay will be determined in conformance with the provisions in Section M. Contractor shall be entitled to no other compensation for that delay.

Z. LOCATION OF UNDERGROUND FACILITIES (OFFSITE WORK ONLY)

Contractor is required to obtain digging permits prior to start of excavation by contacting the appropriate permitting agencies 15 calendar days in advance. For the Offsite work scan the construction site with electromagnetic or sonic equipment, and mark the surface of the ground where existing underground utilities are discovered. Verify the elevations of existing piping, utilities, and any type of underground obstruction not indicated or specified to be removed but indicated or discovered during scanning in locations to be traversed by piping, ducts, and other work to be installed. Verify elevations before installing new work closer than nearest manhole or other structure at which an adjustment in grade can be made. Perform potholing to confirm location of all the utilities along the construction alignment prior to start of the construction. The Contractor is responsible for all costs associated with these investigations including the cost of equipment, labor and materials required for any confined space entry.

AA. UNFORESEEN HAZARDOUS OR REGULATED MATERIALS

All known hazardous or regulated materials are indicated in the Contract documents. If material that is not indicated in the Contract documents is encountered that may be dangerous to human health upon disturbance during construction operations, stop that portion of work and notify Authority immediately. Intent is to identify materials such as PCB, lead paint, mercury, petroleum products, and friable and non-friable asbestos. Within 14 calendar days, the Authority will determine if the material is hazardous. If the material is not hazardous or poses no danger, the Authority will direct Contractor to proceed without change. If the material is hazardous and handling of the material is necessary to accomplish the work, Authority will contract with a qualified environmental remediation/hazardous materials removal Contractor for such remediation or removal as may be necessary. The remediation or removal will be performed in compliance with applicable State, Federal, and local environmental laws and regulations.

Contractor shall immediately notify the Authority of any delays to the Contractor's operations as a direct result of Unforeseen Hazardous and Regulated Materials. These delays will be considered utilities related delays within the meaning of Section Z. Utilities Related Delays and compensation for the delay will be determined in conformance with the provisions in Section M. Contractor shall be entitled to no other compensation for that delay.

BB. TRENCHING AND EXCAVATIONS

In the event the Contractor is required to dig any trench or excavation that extends deeper than four (4) feet below the surface in order to perform the work authorized under the Agreement, Contractor agrees to promptly notify the Authority in writing and before further disturbing the site, if any, of the conditions set forth below are discovered:

1. Materials that the Contractor believes may be hazardous waste, as defined in Section 25117 of the Health and Safety Code that is required to be removed to a Class I, Class II, or Class III disposal site in accordance with the provisions of existing law.
2. Subsurface or latent physical conditions at the site differing from those indicated by information about the site made available to bidders prior to the deadline for submitting bids.
3. Unknown physical conditions at the site of any unusual nature, different materially from those ordinarily encountered and generally recognized as inherent in work of the character provided for in the Agreement.

The Authority will promptly investigate the conditions, and if it determines that the conditions do materially so differ, or do involve hazardous waste, and cause a decrease or increase in the Contractor's cost of, or the time required for, performance of any part of the work shall issue a Change Order under the procedures described in the Agreement.

In the event that a dispute arises between the Authority and the Contractor whether the conditions materially differ, or involve hazardous waste, or cause a decrease or increase in the Contractor's cost of, or time required for, performance of any part of the work, the Contractor shall not be excused from any scheduled completion date provided for by the Agreement, but shall proceed with all work to be performed under the Contract. The Contractor shall retain any and all rights provided either by contract or by law which pertain to the resolution of disputes and protests between the contracting parties.

SECTION VIII: SCOPE OF WORK / PROJECT SPECIFICATIONS - EXHIBIT B

**SCOPE OF WORK / PROJECT SPECIFICATIONS
FOR
METROLINK TRAIN STATIONS
PLATFORM DETECTABLE TILES
REPLACEMENT
AND
PAINTED GUIDELINES
RESTRIPING PROJECT**

April 27, 2020

Table of Contents

SECTION 1 3
 1.1 Project Description..... 3
SECTION 2 6
 2.1 Statement of Work..... 6
 2.2 Project Schedule..... 19
ATTACHMENT B1 – Metrolink Station Platform Existing Condition Information . 22
ATTACHMENT B2 – Metrolink Engineering Standard ES3203..... 23
ATTACHMENT B3 – Metrolink Standard Specification 09 61 50..... 25
ATTACHMENT B4 – Metrolink Standard Specification 32 17 23 32
ATTACHMENT B5 – Metrolink Engineering Standard ES1212 35
ATTACHMENT B6 – SCRRRA Application for Right-of-Way Encroachment..... 36
ATTACHMENT B7 – SCRRRA Site Specific Work Plan42
ATTACHMENT B8 – SCRRRA Form 5 47
ATTACHMENT B9 – BNSF Application for Temporary Occupancy 53
ATTACHMENT B10 – Notification Examples 59

SCOPE OF WORK

SECTION 1

DESCRIPTION OF PROJECT

1.1 PROJECT DESCRIPTION

1.1-1. Background

The Orange County Transportation Authority (OCTA), in coordination with Southern California Regional Rail Authority (SCRRA), the cities of Buena Park, Fullerton, Orange, Santa Ana, and Laguna Niguel and San Clemente propose to replace the detectable tiles and restripe the painted guidelines at each train station. These stations are located within the Los Angeles – San Diego – San Luis Obispo (LOSSAN) rail corridor serves Metrolink commuter trains (operated by SCRRA), Amtrak intercity trains, and BNSF Railway and Union Pacific Railroad freight trains and is identified as the second most heavily traveled intercity passenger rail corridor in the nation.

Replacement of the detectable warning tiles and painted guidelines are needed on each platform at the stations listed in this scope of work. OCTA seeks to obtain a licensed contractor to remove and replace deteriorated detectable warning tiles and remove and restripe painted yellow guidelines along the rail platforms serving both Metrolink and Amtrak rail services at Fullerton and Santa Ana Stations and Metrolink rail service at Orange, Laguna Niguel/Mission Viejo, and San Clemente Stations in Orange County.

All Metrolink/Amtrak train stations must comply with the Department of Transportation's Americans with Disabilities Act (ADA) standards for transportation facilities. The objective of the project is to replace the deteriorated detectable warning tiles, reinstall per Metrolink Standards, remove and restripe the yellow safety guidelines and block warning letters along the rail platforms at the selected locations indicated in the Scope of Work (SOW). This project will enhance the safety of the commuting public using this station and provide clear warnings to the passengers with and without disabilities.

Each station is owned and maintained by the city that it serves and OCTA is assisting each city with capital improvements to enhance the safety of passengers at these stations. These safety enhancements will provide visual (contrasting color) and feel (tactile) to enhance public safety and warning of the edge of the rail platform.

1.1-2. Station Locations

The train stations are located in the cities of Buena Park, Fullerton, Orange, Santa Ana, Laguna Niguel, and San Clemente and are identified on the following page:

1. City of Buena Park
Buena Park Metrolink Station
8400 Lakeknoll Drive
Buena Park, California 90621
2. City of Fullerton
Fullerton Metrolink Station
120 East Santa Fe Avenue
Fullerton, California 92832
3. City of Orange
Orange Metrolink Station
194 North Atchison Street
Orange, California 92866
4. City of Santa Ana
Santa Ana Metrolink Station
1000 East Santa Ana Boulevard
Santa Ana, California 92701
5. City of Laguna Niguel
Laguna Niguel/Mission Viejo Metrolink Station
28200 Forbes Road
Laguna Niguel, California 92677
6. City of San Clemente
San Clemente Metrolink Station, (North Beach)
1850 Avenida Estacion
San Clemente, California 92672

1.1-3. Passenger Train Routes and Schedules

Train Routes

The Buena Park Station Serves the following passenger rail routes:

- Metrolink Orange County and 91/Perris Valley Lines: 34 trains
- Amtrak Pacific Surfliner: 26 trains (pass through only)

The Fullerton Station serves the following passenger rail routes:

- Metrolink Orange County and 91/Perris Valley Lines: 38 trains
- Amtrak Pacific Surfliner: 26 trains

The Orange Station serves the following passenger rail routes:

- Metrolink Orange County and Inland Empire-Orange County Lines: 43 trains
- Amtrak Pacific Surfliner: 26 trains (pass through only)

The Santa Ana Station serves the following passenger rail routes:

- Metrolink Orange County and Inland Empire-Orange County Lines: 43 trains
- Amtrak Pacific Surfliner: 26 trains

The Laguna Niguel/Mission Viejo Station serves the following passenger rail routes:

- Metrolink Orange County and Inland Empire-Orange County Lines: 39 trains
- Amtrak Pacific Surfliner: 26 trains (pass through only)

The San Clemente Station serves the following passenger rail routes:

- Metrolink Orange County and Inland Empire-Orange County Lines: 16 trains
- Amtrak Pacific Surfliner: 26 trains (pass through only)

Train Schedules

Please refer to the following Metrolink's and Amtrak's websites for the latest rail timetables for project scheduling and coordination:

<http://www.metrolinktrains.com/schedules/>

<http://www.amtrak.com/pacific-surfliner-train>

SECTION 2

STATEMENT OF WORK

- 2.1. The CONTRACTOR shall comply with all federal, state, local, and railroad specific laws and regulations. OCTA requests the CONTRACTOR to provide a lump sum bid for all base scope of work items which are included and described below (herein referred to as PROJECT)

2.1-1. Detectable Warning Tiles

The CONTRACTOR shall furnish all necessary labor, equipment, materials and supplies to remove existing discolored detectable warning tiles and replace with new Federal Yellow detectable warning tiles along all existing train platforms at six (6) Metrolink Stations in Orange County, California as listed in Attachment B1 – Metrolink Station Platform Information and adhere to Metrolink Engineering Standard ES3203 and Metrolink Standard Specification Section 09 61 50. The Mini-High platform is excluded from this SOW. The CONTRACTOR shall perform the work in conformance with the all requirements of Attachments B2 and B3. The Contractor shall submit a construction staging plan which would ensure no impact to the existing passenger parking lot and the railroad operation. The Contractor's staging plan shall illustrate the number of days needed for a railroad flagman. Contractor shall be responsible for day-to-day coordination during construction to ensure that a flagger is present when needed. The contractor shall repair or fill concrete voids with Sika Quick 2500 repair mortar or approved equal as needed for the installation of new detectable warning tiles.

- A. The Buena Park Station shall require the removal and replacement of the existing detectable warning tiles on both platforms.
- B. The Fullerton Station shall require the removal and replacement of eight tiles on the west end of Track 3, which has been damaged along the edge of the platform. An additional 8 tiles along Track 1, have lifted from the concrete and will need to be removed and replaced. The concrete for both platforms will need to patch and leveled with Sika Quick 2500 or approved equal prior to tile placement.
- C. The Orange Station existing detectable warning tiles are set back approximately 3" from the edge on platform 1 and approximately 3.5" on platform 2. The new detectable warning tiles shall be installed to the edge of platform. The groove behind the original tiles will need to be cleaned of existing sealant, dust and debris and filled with Sika Quick 2500 or approved equal.
- D. The Santa Ana Station shall require the removal and replacement of the existing detectable warning tiles on both platforms. Note that Track 1, the existing tiles are set back approximately 2" from the edge of platform. The new detectable warning tiles shall be installed to the edge of platform. Therefore, the groove

behind the original tiles will need to be cleaned of existing sealant, dust and debris and filled with Sika Quick 2500 or approved equal.

- E. The Laguna Niguel/Mission Viejo Station shall require the removal and replacement of the existing detectable warning tiles from platform 1 and 2.
- F. The San Clemente Station is comprised of a single platform and shall require the removal and replacement of the existing detectable warning tiles from platform.

2.1-2. Directional Detectable / Textured Tiles

The CONTRACTOR shall furnish all necessary labor, equipment, materials and supplies to remove existing discolored detectable warning tiles, this includes removal of adhesives and other securement material and preparing the surface per manufacture's recommendation. The detectable tiles will be replaced with new Federal Yellow detectable warning tiles along all existing train platforms at six (6) Metrolink Stations in Orange County, California as listed in Attachment B1 – Metrolink Station Platform Information and adhere to Metrolink Engineering Standard. The Mini-High platform is excluded from this SOW.

- A. The Orange Station has directional tiles at select locations which shall be removed and replaced with a concrete surface to match existing color along the existing train platform and conform to Metrolink Standard.
- B. The Santa Ana Station Track 1 has directional tiles which shall be removed and replaced with concrete surface or decorative tile to match existing along the existing train platform and conform to Metrolink Standard. Remove asphalt patches or damage tiles located between the edge of platform and the yellow painted stripe and replaced with concrete surface or decorative tile to match existing.
- C. The Laguna Niguel / Mission Viejo Station has directional tiles which shall be removed and replaced with concrete surface to match existing color along the existing train platform and conform to Metrolink Standard.

2.1-3. Striping and Marking

The CONTRACTOR shall furnish all necessary labor, equipment, materials and supplies to remove existing yellow warning striping, black contrast line, and markings. The CONTRACTOR shall restripe and remark along the existing train platforms at six (6) Metrolink Stations in Orange County, California as listed in Attachment B1 – Metrolink Station Platform Existing Information and per Attachment B 4 – Metrolink Standard Specification Section 32 17 23 and Attachment B5 – Metrolink Engineering Standard ES1212. The Mini-High platform is excluded from this SOW. All locations where removed striping and marking are not restriped or remarked shall match the existing platform concrete texture and color.

- A. The Buena Park, Orange, Laguna Niguel/Mission Viejo and San Clemente Stations will follow the standard striping plan as shown in Attachment B2.

- B. The Fullerton and Santa Ana Stations will utilize Alternate-A striping plan as shown in Attachment B2.
- C. The Santa Ana Station shall require repairs or replacement of existing loose or damaged inlaid tiles prior to application of striping and marking. The new striping and markings will be placed on existing tiles at Track 1. Therefore, CONTRACTOR shall determine proper paint type and submit for approval to ensure proper adhesion to the existing ceramic tiles.

2.1-4. Right of Way Encroachment

- A. **OCTA/SCRRA:** The Contractor shall be responsible to complete the “Application for Right-of-Way Encroachment” with SCRRA (Attachment B6), including but not limited to the required insurance, site-specific work plan (Attachment B7), and drawings as required for this PROJECT. Additionally, the contractor shall complete “Indemnification and Assumption of Liability Agreement” or SCRRA Form No. 5 (Attachment B8). All costs for re-mobilization and downtime due to delays in obtaining the required agreement shall be included in the bid prices for this PROJECT and no additional compensation shall be allowed. Please see Attachment B1 for Stations requiring SCRRA permits.
- B. **BNSF:** The Contractor shall be responsible to obtain the “Application for Temporary Occupancy Permit” with BNSF (Attachment B9), including but not limited to the required insurance, as required for this PROJECT. All costs for re-mobilization and downtime due to delays in obtaining the required agreement shall be included in the bid prices for this PROJECT and no additional compensation shall be allowed. Please see Attachment B1 for Stations requiring BNSF permits.
- C. **Cities:** Access to each City owned right-of-way shall be coordinated with OCTA. The Station platforms are owned, operated, and maintained by each City where the station is located. All costs for re-mobilization, schedule and downtime due to delays in obtaining the required access to each station shall be included in the bid prices for this PROJECT and no additional compensation shall be allowed.

2.1-5. Railroad Worker Protection

- A. The Contractor shall coordinate with OCTA, SCRRRA, and BNSF to schedule railroad flagging protection and receive authorization to perform work at each station. OCTA will reimburse the cost of flagmen protection up to the maximum days indicated in Section 2.1-20. Additional flagmen protection beyond the maximum days will be reviewed for approval by OCTA subject to the purpose and need.
- B. All workers working onsite shall be trained by both SCRRRA and BNSF third party contractor safety training. OCTA will reimburse the cost of one (1) SCRRRA group training class and the online BNSF classes for up to ten (10) people. Additional safety training classes (group or online) beyond the initial session will be reviewed for approval by OCTA subject to the purpose and need or may be attained at Contractor's expense.
- C. The railroad flagman or Railroad Worker in Charge (RWIC) shall determine the appropriate protection for the PROJECT. The Contractor shall be required to clear any live track as determined by the flagman. All workers, equipment, and materials shall be cleared from the track and all equipment shall be held at idle until the train has passed, and the flagman has authorized the resumption of work. The minimum clearance distance for workers, material, and equipment shall be at the discretion of the RWIC, but in general the following clearances can be reasonably anticipated:
 - 1. At the sole discretion of the RWIC, work may continue without stopping while trains pass, as long as the equipment is not moving, swinging, lifting, etc.
 - 2. Stationary and idling equipment shall be a minimum of 15-feet clear of the track. The operator may stay on equipment while the trains pass. All other personnel shall maintain a minimum of 25-feet clear of the track while the train passes, unless otherwise directed by the flagman.
- D. Railroad flagman shall be in direct contact with Contractor's personnel and equipment being protected. If work is spread out over a section of track and a single flagman cannot contact all personnel and equipment, additional flagman shall be required. The Contractor shall maintain continuous radio contact with all personnel and equipment operators as necessary for communication with the flagman/RWIC.
- E. Any Contractor personnel found to be acting in violation of railroad safety of operating rules and regulations will be removed and banned from the worksite.
- F. A written request for flagging services will be required at least 30 days prior to the time when such services are needed.

2.1-6. Schedules

- A. The scheduling and execution of the PROJECT in accordance with the Contract Documents are the responsibility of the CONTRACTOR. Schedules shall represent a practical plan to complete the PROJECT within the Contract Time and shall convey the CONTRACTOR's intent in the manner of prosecution and progress of the PROJECT. The submittal of schedules shall be understood to be the CONTRACTOR's representation that the schedule meets the requirements of the Contract Documents and that the PROJECT will be executed in the sequence and duration indicated in the schedule. The CONTRACTOR shall involve and coordinate with all Sub-Contractors, third parties, and material suppliers in the development and updating of schedules.
- B. The CONTRACTOR shall submit a construction baseline schedule 15 working days following Notice to Proceed. Upon approval by OCTA, this schedule will become the Construction Baseline Schedule. The approved Construction Baseline Schedule shall be basis for progress schedule submittals. CONTRACTOR in the Schedule must include the following elements:
 - 1. Work items and submittals identified in accordance with a Work Breakdown Structure (WBS) as developed by CONTRACTOR and approved by OCTA.
 - 2. Work items of agencies and other third parties including coordination that may affect or be affected by CONTRACTOR activities.
 - 3. Resource loading of work items in work hours to show the effort required to perform the work. Resource loading shall be used to develop plan and actual progress curves.
 - 4. The construction baseline schedule shall include all data necessary to represent the total PROJECT and the critical path shall be clearly identified.
 - 5. The order, sequence, and interdependence of significant work items shall be reflected on the construction schedule.
- C. CONTRACTOR shall submit a copy of the Progress Schedule to OCTA along with the application and certification for payment.
- D. Three-Week Look Ahead Schedule shall contain one week of historical information and three weeks of planned activities in support of and consistent with the Construction Baseline Schedule or current Progress Schedule.

- F. Submit first Three-Week Look Ahead Schedule at Pre-Construction Meeting. Submit weekly thereafter at Construction Progress Meetings until Final Completion.

Submittals:

- Construction Baseline Schedule
- Three-Week Look Ahead Schedule

2.1-7. Submittals

- A. CONTRACTOR shall identify the required submittals defined in Attachments B3 and B4 and others within the scope of work and contract documents.
- B. The Contract Documents shall be supplemented by shop drawings, working drawings, equipment layout drawings, coordination drawings, lift drawings, product data, samples, and similar submittals prepared by the Contractor or its Subcontractors or Suppliers, of any tier. These materials and similar submittals shall be furnished as required for coordination of the Contractor's work, as required for the coordination of the work with forces of the City or other Contractors working for the City, as required by the various sections of the scope of work, or as requested by OCTA. The purpose of the submittal is to demonstrate for those portions of Work for which submittals are required the manner in which the CONTRACTOR proposes to conform to the information given and the design concept expressed in the Contract Documents.
- C. Submit a schedule of submittals, arranged in chronological order by dates required by the construction schedule. When establishing dates, include the time required for review, ordering, manufacturing, fabrication, and delivery. Include additional time required for making submittal corrections or modifications noted by OCTA, and additional time for handling and reviewing submittals required by those corrections.
- D. Assemble each submittal individually and appropriately for transmittal and handling. Transmit each submittal using a transmittal form. OCTA will return, without review, any submittals received from sources other than the Contractor.
- E. Allow 14 days for initial review of each submittal. Allow additional time if coordination with subsequent submittals is required. OCTA will advise the CONTRACTOR when a submittal being processed must be delayed for coordination.

Submittals:

- Schedule of Submittals
- Submittals

2.1-8. Project Management and Coordination Project Meetings

- A. Preconstruction Meeting: OCTA will schedule and conduct a preconstruction meeting before starting construction, at a time convenient to OCTA, but no later than 15 days after the Notice to Proceed. The meeting will review roles and responsibilities and personnel assignments. CONTRACTOR attendees shall include the project manager and its superintendent; major Sub-Contractors; suppliers; and other concerned parties shall attend the conference. Participants at the conference shall be familiar with PROJECT and authorized to conclude matters relating to the work.
- B. Progress Meetings: Attend progress meetings at weekly intervals.
Attendees: In addition to representatives of OCTA, Cities, and SCRRA, each Contractor, Sub-Contractor, supplier, and other entity concerned with current progress or involved in planning, coordination, or performance of future activities shall be represented at these meetings. All participants at the meeting shall be familiar with the PROJECT and authorized to conclude matters relating to the work.
- C. Review construction schedule and items of significance that could affect progress. Include topics for discussion as appropriate to the status of the PROJECT.

Coordination

- A. All work shall be coordinated with OCTA prior to the start of work. It is anticipated that City maintenance activities will occur each day at the Station. The CONTRACTOR shall coordinate the work with OCTA to minimize work disruptions to all parties. Work around schedules shall be included in the bid prices for this PROJECT and no additional compensation shall be allowed.
- B. Coordinate scheduling and timing of required administrative procedures with other construction activities to avoid conflicts and to ensure orderly progress of the PROJECT.
- C. Coordinate with OCTA, SCRRA, Amtrak, and BNSF to minimize disruptions to rail service with advanced notice of planned work and duration of each activity.
- D. The Contractor shall coordinate PROJECT phasing and flagging requirements with all affected parties.
- E. The Contractor shall keep OCTA fully informed regarding any night or weekend work.
- F. The Contractor shall submit the proposed location of staging areas for OCTA's approval.

2.1-9. Permits and Agreements

- A. This PROJECT does not require permits from each City.
- B. Prior to the start of work, the Contractor shall submit all required documentation, pay for all fees and obtain all applicable permits with SCRRA and BNSF. OCTA will reimburse the permit and application fees associated with SCRRA and BNSF. The Contractor shall submit original fee invoices to OCTA prior to any reimbursement. No reimbursement to the Contractor will be made for the time or associated costs incurred in procuring permits or agreements.

2.1-10. Construction Waste Management and Disposal

- A. This section contains the procedural requirements for salvaging nonhazardous demolition and construction waste, recycling nonhazardous demolition waste and disposing of nonhazardous demolition and construction waste.
- B. The CONTRACTOR shall provide handling, containers, storage, signage, transportation, and other items as required to handle the waste generated during the entire duration of the PROJECT.
- C. The CONTRACTOR shall be responsible for removal of construction waste generated from the PROJECT and transported to a proper disposal facility qualified to receive the waste in accordance with applicable federal, state, and local laws and ordinances.
- D. Provide receipts and tickets from the vendor or facility which collected or received the waste materials.
- E. Contractor shall not dispose of any construction waste in City's waste receptacles or containers.

2.1-11. Utility

All existing utility hand holes or pull boxes located on the platform requiring grade adjustment due to the proposed work shall be considered incidental to and included in the bid prices for this PROJECT and no additional compensation shall be allowed.

2.1-12. Site Safety Requirements

Work specified in this Section consists of initiating, maintaining, and supervising all safety precautions and programs and assuring a safe Work Site and safe operations around active tracks. The Contractor shall be solely responsible for ensuring that all work performed under the

Contract is performed in strict compliance with all applicable Federal, State, local occupational safety regulations and SCRRRA rules and requirements adopted to protect operations.

- A. The Contractor shall provide a Construction Health and Safety Technician (CHST) with five years of rail construction health and the OCTA Project Manager a resume and qualifications of the designated Health, Safety and Environmental Representative within 10 days after Notice to Proceed (NTP), and shall meet requirements for an OCTA Capital Program as identified in Exhibit H – Level 3 Health, Safety and Environmental (HSE) Specifications. This position shall be responsible for health and safety HSE compliance enforcement of the workers and the protection of the public **at the jobsite at all times** during Contractor’s scope. A site-specific health and safety implementation work plan shall be prepared in accordance with applicable federal and state OSHA regulations and Exhibit H - Level 3 Health, Safety and Environmental (HSE) Specifications for review and acceptance by OCTA. Prepare the required submittals for OCTA’s review and acceptance prior to the start of construction. The designated HSE Representative shall have full stop work authority of all or segments tasks for Contractor’s scope activities.

Protection of the Public

- B. The CONTRACTOR shall make provisions necessary to protect the public from danger, loss of life, loss of property during the performance of this PROJECT.
- C. The CONTRACTOR shall delineate the pedestrian path of travel around the work zone and provide all necessary signage to guide passengers to the correct path and away from the work zone. The CONTRACTOR shall provide a pedestrian path of travel plan for each phase of work to OCTA for review and acceptance prior to the start of construction.
- D. The CONTRACTOR shall remove or demolish only what can be replaced or restriped the same day. No Section of the platform shall be left uneven, unprotected from the public, or with trip hazardous until the next workday.

Submittals:

- Resume of CHST qualified HSE Representative
- Site-specific health and safety implementation work plan
- Pedestrian path of travel plan

2.1-13. Site Security Requirements

The CONTRACTOR shall be solely responsible for the security of CONTRACTOR's facilities, materials, and equipment used or stored at the worksite. OCTA, SCRRRA, Amtrak, BNSF, or the Cities shall not be responsible for such security measures, and the CONTRACTOR shall take necessary and prudent measures to ensure the security of the CONTRACTOR owned facilities, materials, and equipment, including but not limited to security fencing, locked storage facilities, secured equipment areas, posted security personnel, and other measures deemed necessary by the CONTRACTOR. The cost for any damaged, vandalized, or stolen items shall be borne solely by the CONTRACTOR.

2.1-14. Site Maintenance Requirements

- A. The CONTRACTOR shall install and maintain temporary barricades and/or delineators to protect passengers and the public where permissible.
- B. The temporary barricades and/or delineators shall be removed at the end of each workday.
- C. The CONTRACTOR shall ensure the work site is kept clean.

2.1-15. Temporary Environmental Controls

The CONTRACTOR shall comply with all legal requirements applicable to execution of this construction consists of eliminating or minimizing air, water, and noise pollution generated by construction activities.

- A. Air Pollution Controls
 - 1. The CONTRACTOR shall comply with all requirements for controlling fugitive dust including specific impact mitigation measures contained in the latest version of the South Coast Air Quality Management District (SCAQMD) Rules and Regulations Rule 403 that include minimum procedures and techniques.
 - 2. Use construction equipment designed and equipped to prevent or control air pollution in conformance with the most restrictive regulations of the EPA, state, and local authorities. Maintain evidence of such design and equipment and make it available for inspection by OCTA or its designee.
 - 3. Establish and maintain records of the routine maintenance program for internal combustion engine powered vehicles and equipment used on the PROJECT. Keep records available for inspection by OCTA or its designee.

B. Water Pollution Controls

1. The CONTRACTOR shall prevent construction related pollutants from contacting stormwater in accordance with latest edition of the California Storm Water Best Management Practice Handbook.
2. All cleaning, fueling, and maintenance performed on the site should occur in an area designated for the activity and at least 50 feet away from downstream storm drain facilities. Avoid "topping-off" of fuel tanks. Use drip pans underneath hose and pipe connections and other leak-prone spots.
3. The CONTRACTOR shall have proper spill prevention, control, and cleanup procedures.
4. The CONTRACTOR shall protect stored materials from rainfall, runoff, and wind dispersal.
5. The CONTRACTOR shall reclaim water where soaps or detergents are used to wash paved areas. A wastewater collection device shall be used to collect wash water and associated solids. The collected runoff and solids must be disposed of properly.
6. The CONTRACTOR shall preserve drainage facilities throughout the duration of the work so that there is no pending or accumulation of water in any work area, there is no flow of water diverted toward the track or out of normal drainage channels, and all culvert inlets and outlets are kept free of debris.
7. The CONTRACTOR shall not wash anything into the track right of way.

C. Noise Pollution Control

1. The CONTRACTOR shall comply with each City's noise ordinance and avoid unnecessary idling of equipment or vehicles.

2.1-16. Notifications

- A. The CONTRACTOR shall notify OCTA and SCRRA at least 14 days in advance of the work scheduled to be performed.

2.1-17. Construction Water Service

- A. The CONTRACTOR shall notify and obtain approval from OCTA prior to the usage of water for any construction purposes. The CONTRACTOR shall not use water from private properties for any reason. The CONTRACTOR shall pay for all costs incurred for any necessary water meter and permits, if required.
- B. The CONTRACTOR in coordination with OCTA may seek approval from each City to use water source available at each station (i.e. irrigation or platform quick connects). At no time shall the customers be inconvenienced or create safety hazards due to water use or water needs.

2.1-18. Working Day

- A. CONTRACTOR's anticipated working hours shall be between 8:00 a.m. and 5:00 p.m. Monday through Friday. Individual Cities may allow contractor to work outside those hours or have additional requirement once contractor provides work plan and obtains permit from individual city.
- B. Deviations from these working hours will not be permitted without prior written approval from OCTA and approval from the City.
- C. No work shall be performed by the CONTRACTOR on Sundays or OCTA Designated Holidays. The designated holidays are New Year's Day, Memorial Day, Independence Day, Labor Day, Thanksgiving Day, Day after Thanksgiving, Christmas Day, and Day after Christmas Day.

2.1-19. Extra Stock

- A. Spare Material – The CONTRACTOR shall **not** provide the percentages of spare materials specified in Attachment B3.

2.1-20. Allowances

- A. Metrolink and BNSF Flagging – The allowance for flagging services provided by SCRRRA or BNSF will be paid for each day a flagman is requested and used. The CONTRACTOR shall provide all invoices and daily sign-in records to obtain payment for each day flagmen services were rendered. The allowance for flagman at Fullerton Station is 5 days and Santa Ana and Laguna Niguel/Mission Viejo Stations are 20 days each at the current respective flagman rate per day. Additional flagmen protection beyond the maximum days will be reviewed for approval by OCTA subject to the purpose and need.
- B. Metrolink Permit Review, Administration, and Training – The allowance will cover one SCRRRA Third Party Safety Orientation Training (group training), plan reviews, and permit processing. Additional safety training beyond the initial session will be reviewed for approval by OCTA subject to the purpose and need or classes may be attained at CONTRACTOR's expense. The CONTRACTOR shall provide all invoices and final approved permits to obtain payment.
- C. BNSF Permit Review, Administration, and Training – The allowance will cover ten online BNSF Third Party Safety Orientation Trainings (individual online training available on www.contractororientation.com), plan reviews, and permit processing. Additional online safety training beyond the initial session will be reviewed for approval by OCTA subject to the purpose and need or classes may be attained at CONTRACTOR's expense. The CONTRACTOR shall provide all invoices and final approved permits to obtain payment.

2.2. Project Schedule

Metrolink Train Stations Platform Detectable Tile Replacement and Painted Guideline Restriping Project

Activity	Proposed Date
A. ISSUE IFB	April 27, 2020
B. COMPLETION OF CONSTRUCTION (180 days)	March 24, 2021

ID	Task Mode	WBS	Task Name	Duration	Start	Finish	Predecessor	2nd Quarter			3rd Quarter			4th Quarter			1st Quarter			2nd Quarter		
								Apr	May	Jun	Jul	Aug	Sep	Oct	Nov	Dec	Jan	Feb	Mar	Apr	May	Jun
1		P1.0	Issue IFB	42 days	Mon 4/27/20	Tue 6/23/20																
2		P1.1	Detectable Tile Construction	179.5 days	Thu 7/16/20	Wed 3/24/21																
3		P1.2	Pre-Construction Services	73 days	Thu 7/16/20	Mon 10/26/20																
4		P100	NTP	10 days	Thu 7/16/20	Wed 7/29/20																
5		P101	Submit Submittals	10 days	Thu 7/30/20	Wed 8/12/20																
6		P102	Submittal Review	10 days	Thu 8/13/20	Wed 8/26/20																
7		P108	Long-Lead Material (DWT)	20 days	Thu 8/13/20	Wed 9/9/20	5															
8		P103	Revise Submittals	10 days	Thu 8/27/20	Wed 9/9/20	6															
9		P104	Approve Submittals	10 days	Thu 9/10/20	Wed 9/23/20	8															
10		P105	Permits (SCRRA and BNSF)	53 days	Thu 7/30/20	Mon 10/12/24																
11		P106	Training (SCRRA and BNSF)	53 days	Thu 7/30/20	Mon 10/12/24																
12		P107	Environmental Testing (Existing striping and/or tiles)	10 days	Tue 10/13/20	Mon 10/26/21																
13		BP	Buena Park Station (Day)	24 days	Tue 10/27/20	Fri 11/27/20																
14		BP1	Platform 1 (690 ft)	12 days	Tue 10/27/20	Wed 11/11/20																
15		BP100	Mobilization & Site Prep	1 day	Tue 10/27/20	Tue 10/27/20	12															
16		BP101	Remove existing DWTs and install new DWTs	9 days	Wed 10/28/20	Mon 11/9/20	15															
17		BP102	Remove existing striping and marking	1 day	Mon 11/9/20	Mon 11/9/20	16FS-1 d															
18		BP103	Finish new striping and marking	1 day	Tue 11/10/20	Tue 11/10/20	17															
19		BP104	Final Inspection	1 day	Wed 11/11/20	Wed 11/11/20	18															
20		BP2	Platform 3 (690 ft)	12 days	Thu 11/12/20	Fri 11/27/20																
21		BP201	Mobilization & Site Prep	1 day	Thu 11/12/20	Thu 11/12/20	19															
22		BP202	Remove existing DWTs and install new DWTs	9 days	Fri 11/13/20	Wed 11/25/20	21															
23		BP203	Remove existing striping and marking	1 day	Wed 11/25/20	Wed 11/25/20	22FS-1 d															
24		BP204	Finish new striping and marking	1 day	Thu 11/26/20	Thu 11/26/20	23															
25		BP205	Final Inspection	1 day	Fri 11/27/20	Fri 11/27/20	24															
26		O	Orange Station (Night)	24 days	Fri 11/27/20	Wed 12/30/20	24															
27		O1	Platform 1 (690 ft)	12 days	Fri 11/27/20	Mon 12/14/20																
28		O100	Mobilization & Site Prep	1 day	Fri 11/27/20	Fri 11/27/20																
29		O101	Remove existing DWTs and install new DWTs	9 days	Mon 11/30/20	Thu 12/10/20	28															
30		O102	Remove existing striping and marking	1 day	Thu 12/10/20	Thu 12/10/20	29FS-1 d															
31		O103	Finish new striping and marking	1 day	Fri 12/11/20	Fri 12/11/20	30															
32		O104	Final Inspection	1 day	Mon 12/14/20	Mon 12/14/20	31															
33		O2	Platform 2 (690 ft)	12 days	Tue 12/15/20	Wed 12/30/20																
34		O200	Mobilization & Site Prep	1 day	Tue 12/15/20	Tue 12/15/20	32															
35		O201	Remove existing DWTs and install new DWTs	9 days	Tue 12/15/20	Fri 12/25/20	34FS-1 d															
36		O202	Remove existing striping and marking	1 day	Mon 12/28/20	Mon 12/28/20	35															
37		O203	Finish new striping and marking	1 day	Tue 12/29/20	Tue 12/29/20	36															
38		O204	Final Inspection	1 day	Wed 12/30/20	Wed 12/30/20	37															
39		F	Fullerton Station (Day) - Platform 3 & 1 (64 ft)	6.5 days	Wed 12/30/20	Thu 1/7/21	37															
40		F100	Mobilization & Site Prep	1 day	Wed 12/30/20	Wed 12/30/20	36															
41		F101	Remove existing DWTs and install new DWTs	4 days	Thu 12/31/20	Tue 1/5/21	40															
42		F102	Remove and replace existing striping and marking	1 day	Wed 1/6/21	Wed 1/6/21	41															

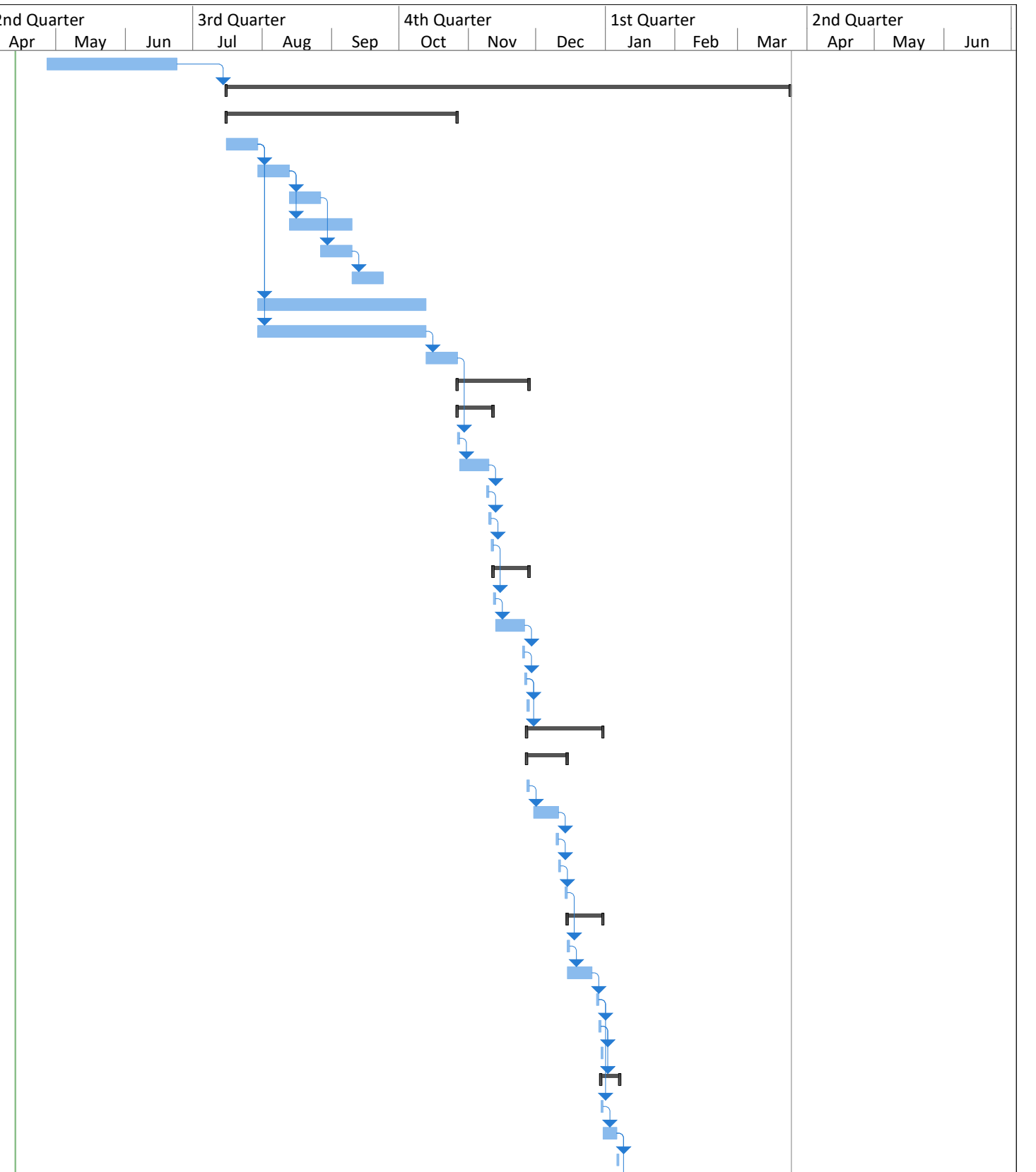

Project: Project1 Date: Mon 4/13/20	Task		Project Summary		Inactive Milestone		Manual Summary Rollup		Deadline	
	Split		External Tasks		Inactive Summary		Manual Summary		Progress	
	Milestone		External Milestone		Manual Task		Start-only		Manual Progress	
	Summary		Inactive Task		Duration-only		Finish-only			

ID	Task Mode	WBS	Task Name	Duration	Start	Finish	Predecessor	2nd Quarter			3rd Quarter			4th Quarter			1st Quarter			2nd Quarter		
								Apr	May	Jun	Jul	Aug	Sep	Oct	Nov	Dec	Jan	Feb	Mar	Apr	May	Jun
43		F103	Retouch adjacent black stripe	0.5 days	Wed 1/6/21	Wed 1/6/21	41															
44		F104	Final Inspection	1 day	Wed 1/6/21	Thu 1/7/21	43															
45		SA	Santa Ana Station (Night)	17 days	Thu 1/7/21	Mon 2/1/21																
46		SA1	Platform 1 (690 ft)	11 days	Thu 1/7/21	Fri 1/22/21																
47		SA100	Mobilization & Site Prep	1 day	Thu 1/7/21	Fri 1/8/21	44															
48		SA101	Remove existing DWTs and install new DWTs	9 days	Fri 1/8/21	Thu 1/21/21	47															
49		SA102	Concrete patch	2 days	Wed 1/20/21	Fri 1/22/21	48FS-1 d															
50		SA103	Brick / Tile repair	1 day	Wed 1/20/21	Thu 1/21/21	48FS-1 d															
51		SA104	Remove existing striping	1 day	Fri 1/8/21	Mon 1/11/21	47															
52		SA105	Finish new striping and marking (Special paint for tiles)	1 day	Mon 1/11/21	Tue 1/12/21	51															
53		SA106	Final Inspection	1 day	Tue 1/12/21	Wed 1/13/21	52															
54		SA2	Platform 2 (890 ft)	13 days	Wed 1/13/21	Mon 2/1/21																
55		SA200	Site Prep	1 day	Wed 1/13/21	Thu 1/14/21	53															
56		SA201	Remove existing DWTs and install new DWTs	9 days	Thu 1/14/21	Wed 1/27/21	55															
57		SA202	Remove existing striping	1 day	Wed 1/27/21	Thu 1/28/21	56															
58		SA203	Finish new striping and marking	1 day	Thu 1/28/21	Fri 1/29/21	57															
59		SA204	Final Inspection	1 day	Fri 1/29/21	Mon 2/1/21	58															
60		SA205	Track 1A Remove and replace striping and marking	2 days	Wed 1/27/21	Fri 1/29/21	56															
61		LNMV	Laguna Niguel/Mission Viejo Station (Night)	28 days	Mon 2/1/21	Thu 3/11/21																
62		LNMV1	Platform 1 (600 ft)	14 days	Mon 2/1/21	Fri 2/19/21																
63		LNMV10	Mobilization & Site Prep	1 day	Mon 2/1/21	Tue 2/2/21	59															
64		LNMV10	Remove existing DWTs and install new DWTs	9 days	Tue 2/2/21	Mon 2/15/21	63															
65		LNMV10	Concrete patch	3 days	Thu 2/11/21	Tue 2/16/21	64FS-2 d															
66		LNMV10	Remove existing striping and marking	1 day	Tue 2/16/21	Wed 2/17/21	65															
67		LNMV10	Finish new striping and marking	1 day	Wed 2/17/21	Thu 2/18/21	66															
68		LNMV10	Final Inspection	1 day	Thu 2/18/21	Fri 2/19/21	67															
69		LNMV2	Platform 2 (600 ft)	14 days	Fri 2/19/21	Thu 3/11/21	67															
70		LNMV20	Mobilization & Site Prep	1 day	Fri 2/19/21	Mon 2/22/21	68															
71		LNMV20	Remove existing DWTs and install new DWTs	9 days	Mon 2/22/21	Fri 3/5/21	70															
72		LNMV20	Concrete patch	3 days	Wed 3/3/21	Mon 3/8/21	71FS-2 d															
73		LNMV20	Remove existing striping and marking	1 day	Mon 3/8/21	Tue 3/9/21	72															
74		LNMV20	Finish new striping and marking	1 day	Tue 3/9/21	Wed 3/10/21	73															
75		LNMV20	Final Inspection	1 day	Wed 3/10/21	Thu 3/11/21	74															
76		SC	San Clemente Station (Day)	9 days	Thu 3/11/21	Wed 3/24/21																
77		SC1	Platform 1 (430 ft)	9 days	Thu 3/11/21	Wed 3/24/21																
78		SC100	Mobilization & Site Prep	1 day	Thu 3/11/21	Fri 3/12/21	75															
79		SC101	Remove existing DWTs and install new DWTs	5 days	Fri 3/12/21	Fri 3/19/21	78															
80		SC102	Concrete patch	1 day	Thu 3/18/21	Fri 3/19/21	79FS-1 d															
81		SC103	Remove existing striping and marking	1 day	Fri 3/19/21	Mon 3/22/21	80															
82		SC104	Finish new striping and marking	1 day	Mon 3/22/21	Tue 3/23/21	81															
83		SC105	Final Inspection	1 day	Tue 3/23/21	Wed 3/24/21	82															

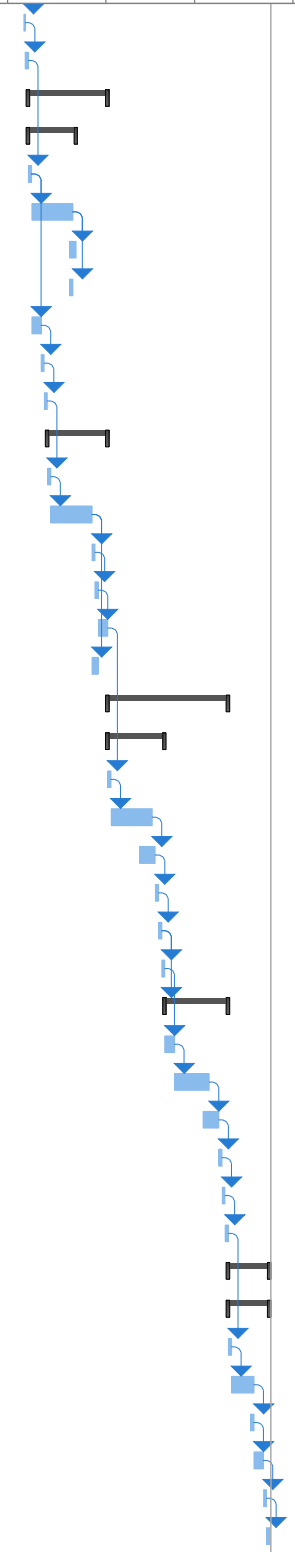

Project: Project1 Date: Mon 4/13/20	Task		Project Summary		Inactive Milestone		Manual Summary Rollup		Deadline	
	Split		External Tasks		Inactive Summary		Manual Summary		Progress	
	Milestone		External Milestone		Manual Task		Start-only		Manual Progress	
	Summary		Inactive Task		Duration-only		Finish-only			

Attachment A - Metrolink Station Platform Existing Condition Information

**Metrolink Stations Platform Detectable Tile Replacement
and Painted Guideline Restriping Project***

	Platform Number	Approximate Length (ft)	Detectable Tiles*				Contrast Stripe*			Yellow Line Stripe*				Directional Bars*				Amtrak Station (Y/N)	SCRRRA Permit & Flagging (Y/N)	BNSF Permit & Flagging (Y/N)
			Tactile Type	Tactile Size (W" X L")	Depth (H")	Color	Stripe Type	Stripe Size (W")	Color	Stripe Type	Stripe Size (W")	Distance from Edge of Platform (in)	Color	Bar Type	Bar Size (W" X L")	Quantity	Color			
Buena Park Metrolink Station	1	690	Cast-in-place	24 X 49	0.50	Yellow	Paint	1	Black	Paint	4	42	Yellow	No Directional Bars				N	N	Y
	2	690	Cast-in-place	24 X 49	0.50	Yellow	Paint	1	Black	Paint	4	42	Yellow	No Directional Bars				N	N	Y
Fullerton Metrolink/Amtrak Station	1	32	Surface Applied	24 x 47	0.50	Yellow	Paint	1	Black	Paint	4	42	Yellow	No Directional Bars				Y	N	Y
	3	32	Surface Applied	24 x 47	0.50	Yellow	Paint	1	Black	Paint	4	42	Yellow	No Directional Bars				Y	N	Y
Orange Metrolink Station	1	600	Cast-in-place	24 X 48	0.50	Yellow	Paint	1	Black	Paint	4	40	Yellow	Surface Applied	48 X 36	5	Yellow	Y	Y	N
	2	600	Cast-in-place	24 X 48	0.50	Yellow	Paint	1	Black	Paint	4	40	Yellow	Surface Applied	48 X 36	5	Yellow	Y	Y	N
Santa Ana Metrolink Station	1	690	Surface Applied	24 X 48	N/A	Yellow	Paint	2.5	Black	Paint	4	43	Yellow	Surface Applied	96 X 12	2	Yellow	N	Y	N
	2	890	Surface Applied	24 X 48	N/A	Yellow	Paint	1.5	Black	Paint	4	43	Yellow	No Directional Bars				N	Y	N
Luna Laguna / Mission Viejo	1	600	Cast-in-place	24 X 24	0.50	Yellow	Paint	2	Black	Yellow	4.5	42	Yellow	Surface Applied	Trapezoid Shape (56 X 120) X 48	12	Yellow	N	Y	N
	2	600	Cast-in-place	24 X 24	0.50	Yellow	Paint	1.5	Black	Yellow	4	42	Yellow	Surface Applied	Trapezoid Shape (56 X 120) X 48	12	Yellow	N	Y	N
	1A	475	Not Included in Scope of Work								Yellow	4	42	Yellow	No Directional Bars				N	Y
San Clemente Metrolink Station (North Beach)	1	430	Cast-in-place	24 X 47	0.50	Yellow	Tape	0.5	Black	Yellow	4	41	Yellow	No Directional Bars				N	Y	N

NOTES:

* All information provided are approximate. Contractor shall field verify existing conditions and measurements.

**Luna Laguna / Mission Viejo directional bars are trapezoid in shape, Base A of 56" x Base B of 120" x Hieght of 48"

NOTE:
SEE SCRRRA STANDARD DRAWING ES3203-02
FOR ADDITIONAL INFORMATION AND DETAILS

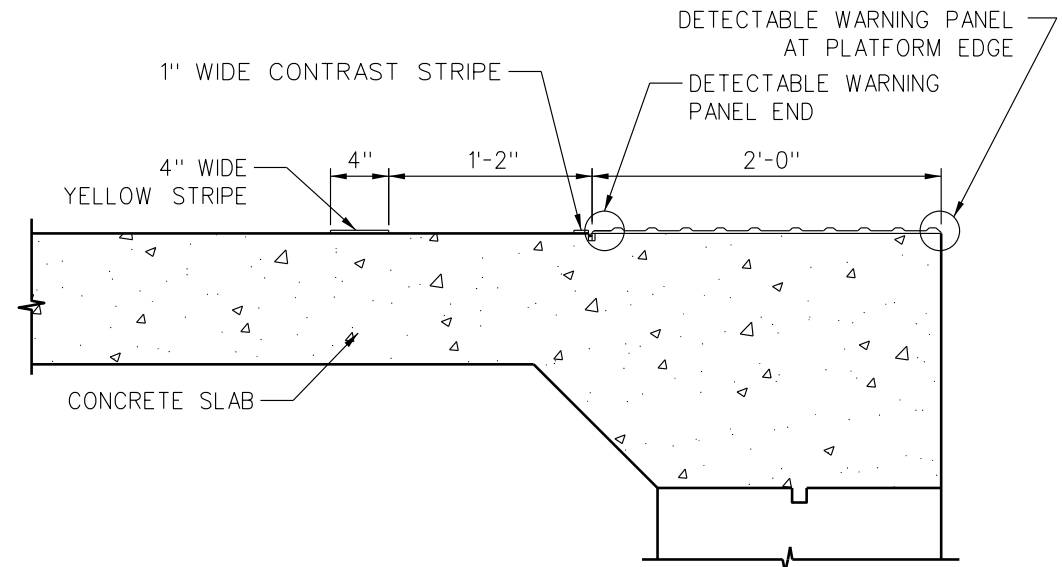
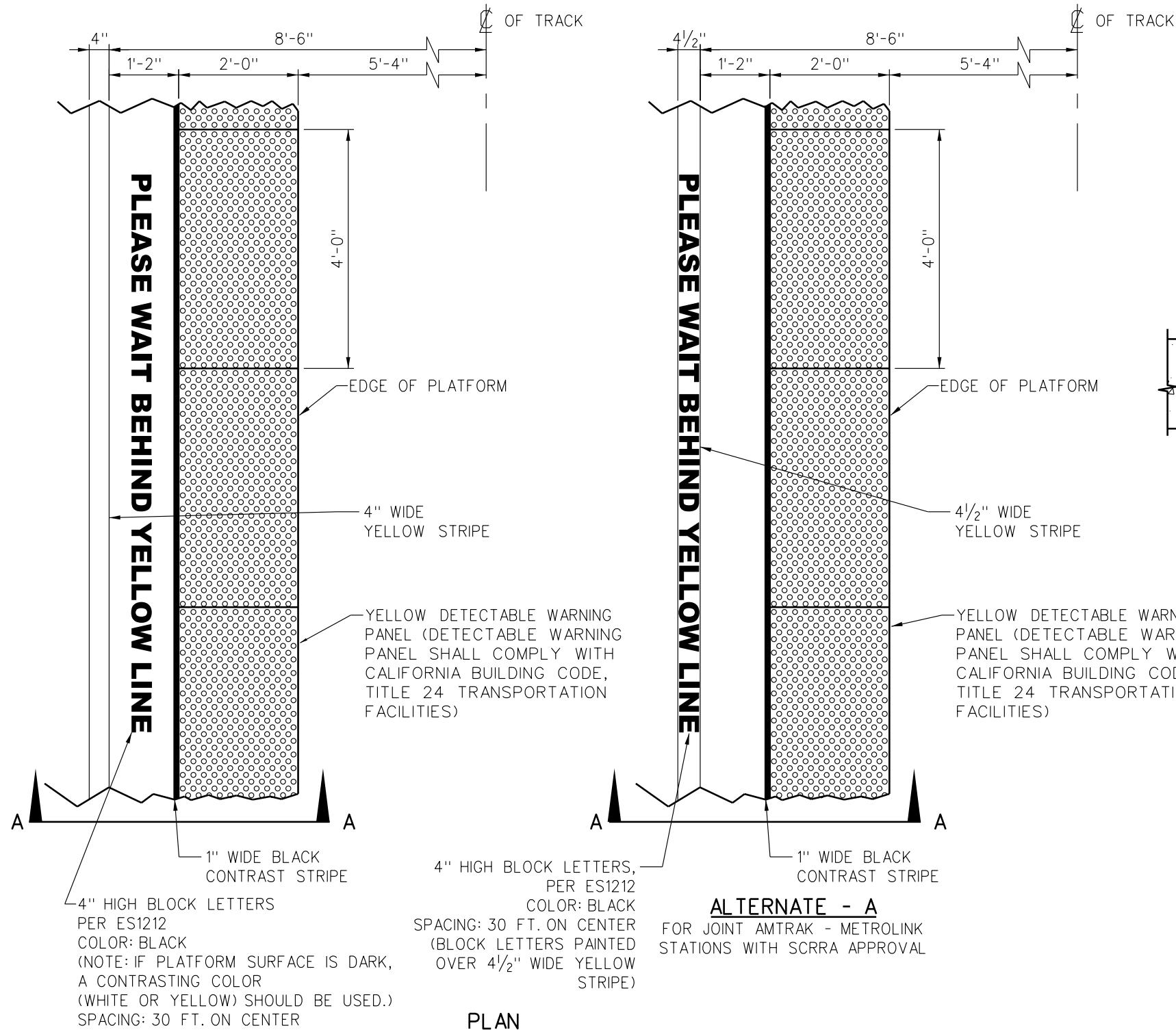

DETECTABLE WARNING PANEL
SECTION A-A
SCALE: 1/2" = 1'-0"

PLAN

ALTERNATE - A
FOR JOINT AMTRAK - METROLINK
STATIONS WITH SCRRRA APPROVAL

REV.	DATE	DESCRIPTION	DES.	ENG.
C	10-07-16	ADD ALTERNATE STRIPING, DETAILS MOVED TO SHEET 02	AC	NDP
B	07-24-13	ADD ALTERNATE STRIPING, DETAILS MOVED TO SHEET 02	AC	NDP
A	05-31-13	REVISED CONTRAST STRIPE	AC	NDP

DRAWN BY:	A. CARLOS	DATE:	04/16/01
ASSISTANT DIRECTOR: STANDARDS & DESIGN			
DIRECTOR OF ENGINEERING AND CONSTRUCTION			

SCRRRA ENGINEERING STANDARDS ARE INTENDED FOR SCRRRA APPROVED USES ONLY.
FOR NON-SCRRRA APPROVED USES:
SCRRRA SHALL NOT BE RESPONSIBLE FOR THE ACCURACY OR COMPLETENESS OF THE DATA OR INFORMATION CONTAINED HEREIN. THE SELECTION AND USE OF THESE STANDARDS IS THE SOLE RESPONSIBILITY OF THE USER AND SHOULD NOT BE USED WITHOUT CONSULTING A REGISTERED PROFESSIONAL ENGINEER. ALL WARRANTIES AND REPRESENTATIONS OF ANY KIND ARE DISCLAIMED. ANYONE MAKING USE OF THIS INFORMATION AGREES THAT IT ASSUMES ALL LIABILITY ARISING FROM SUCH USE. NO PART OF THESE STANDARDS SHOULD BE REPRODUCED OR DISTRIBUTED IN ANY FORM OR BY ANY MEANS, WITHOUT THE PRIOR WRITTEN PERMISSION OF SCRRRA. ALL RIGHTS RESERVED.

METROLINK
SOUTHERN CALIFORNIA REGIONAL RAIL AUTHORITY
ONE GATEWAY PLAZA, 12TH FLOOR, L. A., CA. 90012

ENGINEERING STANDARDS		STANDARD	3203
DETECTABLE WARNING TILE AND MARKING DETAILS		SCALE:	1" = 1'-0"
REVISION	SHEET	C	1 OF 2
		CADD FILE:	ES3203-01

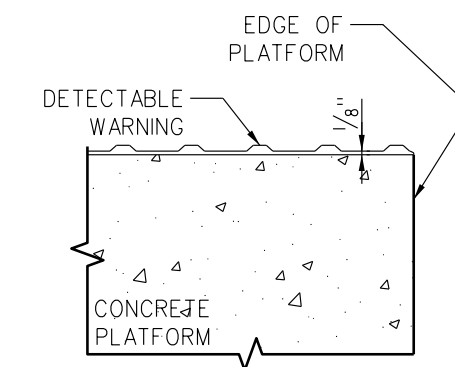
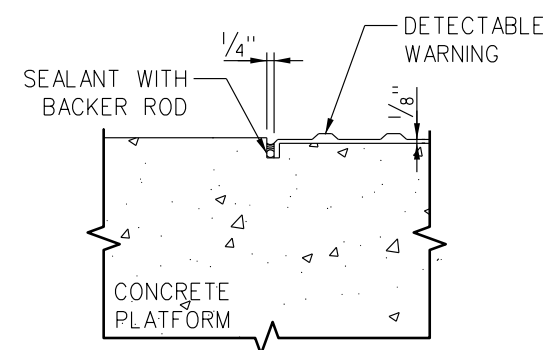
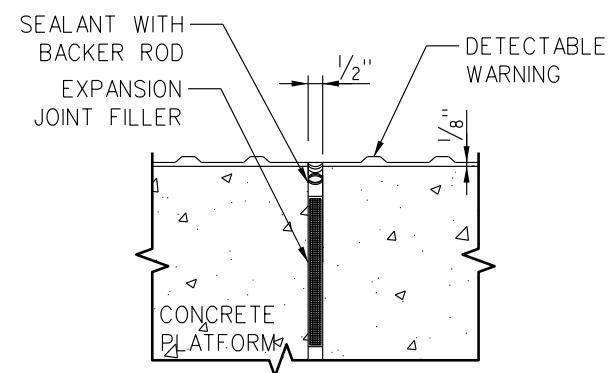
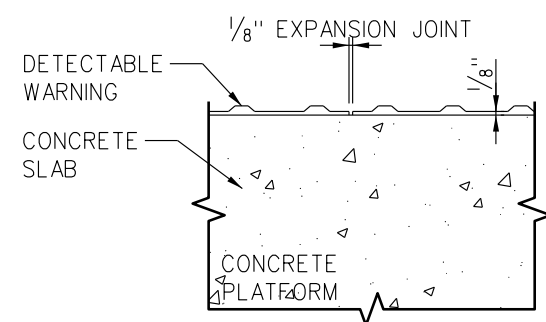
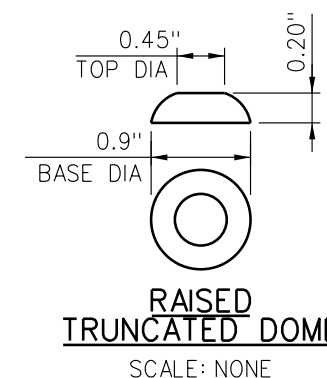
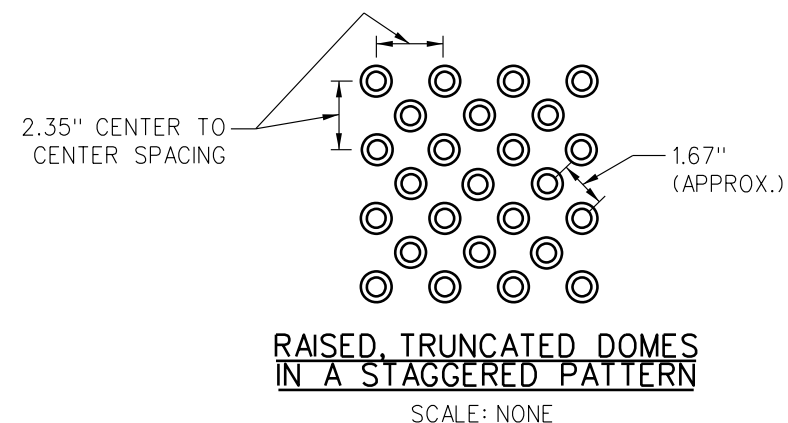
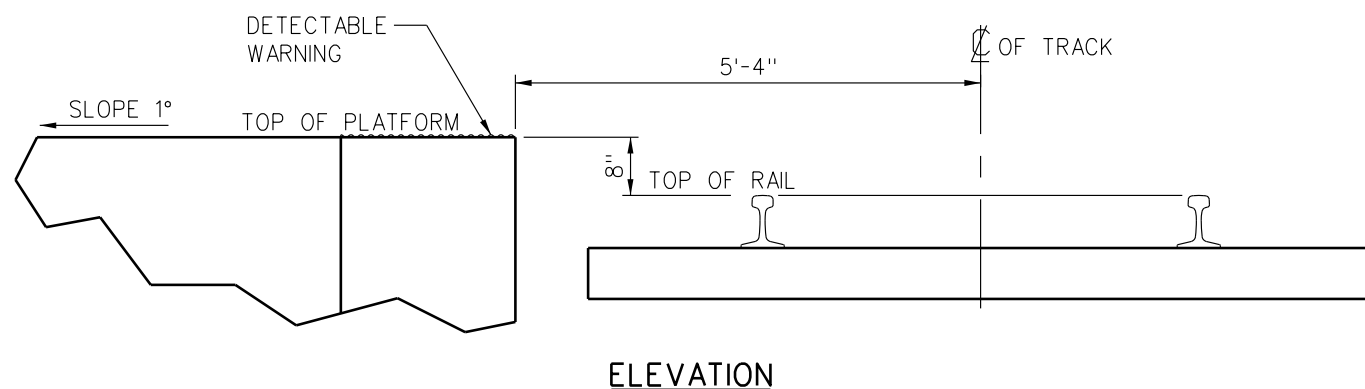

DRAWN BY: A. CARLOS DATE: 07/24/13		SCRR ENGINEERING STANDARDS ARE INTENDED FOR SCRR APPROVED USES ONLY. FOR NON-SCRR APPROVED USES, SCRR SHALL NOT BE RESPONSIBLE FOR THE ACCURACY OR COMPLETENESS OF THE DATA OR INFORMATION CONTAINED HEREIN. THE SELECTION AND USE OF THESE STANDARDS IS THE SOLE RESPONSIBILITY OF THE USER AND SHOULD NOT BE USED WITHOUT CONSULTING A REGISTERED PROFESSIONAL ENGINEER. ALL WARRANTIES AND REPRESENTATIONS OF ANY KIND ARE DISCLAIMED. ANYONE MAKING USE OF THIS INFORMATION AGREES THAT IT ASSUMES ALL LIABILITY ARISING FROM SUCH USE. NO PART OF THESE STANDARDS SHOULD BE REPRODUCED OR DISTRIBUTED IN ANY FORM OR BY ANY MEANS, WITHOUT THE PRIOR WRITTEN PERMISSION OF SCRR. ALL RIGHTS RESERVED.		 SOUTHERN CALIFORNIA REGIONAL RAIL AUTHORITY ONE GATEWAY PLAZA, 12TH FLOOR, L. A., CA. 90012		ENGINEERING STANDARDS DETECTABLE WARNING TILE AND MARKING DETAILS		STANDARD 3203 SCALE: 1" = 1'-0" REVISION SHEET A 2 OF 2 CADD FILE: ES3203-02
REV. DATE DESCRIPTION	DES. ENG.	ASSISTANT DIRECTOR: STANDARDS & DESIGN DIRECTOR OF ENGINEERING AND CONSTRUCTION						

SECTION 09 61 50
DETECTABLE WARNING TACTILES

PART 1 - GENERAL

1.01 DESCRIPTION

- A. This Section includes specifications for detectable warning tactile for pedestrian facilities at grade crossings and station platforms.

1.02 REFERENCE STANDARDS

- A. ASTM International (ASTM):
1. B117 Practice for Operating Salt Spray (Fog) Apparatus
 2. C501 Test Method for Relative Resistance to Wear of Unglazed Ceramic Tile by the Taber Abraser
 3. C1028 Test Method for Determining the Static Coefficient of Friction of Ceramic Tile and Other Like Surfaces by the Horizontal Dynamometer Pull-Meter Method
 4. D570 Test Method for Water Absorption of Plastics
 5. D638 Test Method for Tensile Properties of Plastics
 6. D695 Test Method for Compressive Properties of Rigid Plastics
 7. D790 Test Methods for Flexural Properties of Unreinforced and Reinforced Plastics and Electrical Insulating Materials
 8. D1308 Test Method for Effect of Household Chemicals on Clear and Pigmented Organic Finishes
 9. D5420 Test Method for Impact Resistance of Flat, Rigid Plastic Specimen by Means of a Striker Impacted by a Falling Weight (Gardner Impact)
 10. E84 Test Method for Surface Burning Characteristics of Building Materials
 11. G26 Practice for Operating Light-Exposure Apparatus (Xenon-Arc Type) With and Without Water for Exposure of Nonmetallic Materials (Withdrawn 2000, replaced by G155)
- B. Americans with Disabilities Act (ADA) and Architectural Barriers Act (ABA)
- C. California Building Code, Title 24, Part 2, Section 1121B-Transportation Facilities.

Section 09 61 50

Detectable Warning Tactiles

- D. Standard plans for Public Works Construction, Standard Plan 111-4.
- E. SCRRRA Engineering Standard ES3203, Detectable Warning Tile and Marking Details.

1.03 SUBMITTALS

- A. Shop Drawings: Submit shop drawings showing fabrication details; panel surface profile; fastener locations; plans of panel placement including joints, and material to be used as well as outlining installation materials and procedure. Include procedures for containment and disposal of milling and sawcutting waste water.
 - 1. The shop drawings need not feature a full dimensional layout of the platform edges.
- B. Product Data: Submit manufacturer's literature describing products and installation procedures. Include product data for adhesives and sealants.
- C. Samples: Submit the following samples:
 - 1. Samples of panels measuring at least 12 inches x 12 inches. Panel sample shall include longitudinal edge with integral flange and transverse ship-lap edges.
 - 2. Samples of panels and sealant for verification of color match.
- D. Samples for Verification Purposes: Submit panels of the kind proposed for use.
- E. Maintenance Instructions: Submit manufacturer's specified maintenance practices for each type of panel and accessory as required.
- F. Quality Assurance Submittals:
 - 1. Material Test Reports: Submit test reports from qualified independent testing laboratory indicating that materials proposed for use are in compliance with requirements and meet the properties indicated. Tests which indicate performance for the panels shall have been performed within 3 years of the Invitation to Bid.
 - 2. Submit list of projects in California that successfully demonstrate the proposed products' durability and weatherability.

1.04 QUALITY ASSURANCE

- A. Provide panels and accessories, including panel adhesive, fasteners, and sealants, shall be from a single source. Products shall have been in successful service for a period of five (5) years.
- B. Installer's Qualifications: Engage an experienced Installer certified in writing by panel manufacturer as qualified for installation, who has successfully completed panel installations similar in material, design, and extent to that indicated for Project. Only

Section 09 61 50

Detectable Warning Tactiles

persons who are thoroughly trained and experience in the installation of the panels shall perform the work.

- C. Provide services of manufacturer's field representative who shall be present at all times during installation.

1.05 DELIVERY, STORAGE AND HANDLING

- A. Panel type shall be identified by part number on packages.

1.06 SITE CONDITIONS

- A. Environmental Conditions and Protection: Conduct field operations only when environmental conditions fall within those recommended by manufacturers of the products.

1.07 WARRANTY

- A. Tactiles shall be covered by a written warranty for a period of five years from date of final completion. The warranty includes defective work, breakage, deformation, delamination, fading and chalking of finishes, and loosening of tactiles. Warranty shall include furnishing new materials, removal of existing tactiles, and installation of new tactiles.

1.08 EXTRA STOCK

- A. Furnish not less than five (5) percent additional panels of the total amount installed of each panel and corresponding fasteners. Deliver extra stock to location (within 30 mile radius of work site) designated by the Engineer. Furnish extra stock materials from same manufactured lot as materials installed and enclose in protective packaging with appropriate identification.

PART 2 - PRODUCTS

2.01 PANELS

- A. Manufacturers: Subject to conformance with the requirements of this Section, use products fabricated by the following manufacturers or equal:
 - 1. Transit-Tile of Boulder, CO
 - 2. Armor-Tile by Engineered Plastics, Inc. of Williamsville, NY
 - 3. ADA Solutions, Inc. of North Billerica, MA
- B. Tactiles shall be homogenous glass and carbon reinforced composite or an epoxy polymer composition which is colorfast and UV stable.
- C. There shall be a minimum of 70 percent contrast in light reflection between

the detectable warning and adjoining surface, or the detectable warning shall be Federal Yellow conforming to Federal Color No. 33538. Color shall be homogenous throughout tactile.

D. Truncated Dome Geometry:

1. Truncated dome surface shall comply with ADA and Architectural Barriers Act (ABA) guidelines, 705, Detectable Warnings. (Title 49 CFR Transportation, Part 37.9 Standards for Accessible Transportation Facilities, Appendix A, Section 4.29.2 - Detectable Warnings on Walking Surfaces).
2. Truncated Dome Description:
 - a. For pedestrian facility at highway-rail grade crossings, the truncated domes shall be aligned in a square grid (in-line) with a diameter of nominal 0.9 inch at the base tapering to 0.45 inch at the top and a height of nominal 0.2 inch. The truncated domes shall have a center-to-center spacing of nominal 2.35 inches. Refer to Standard Plan 111-4, Sheet 10 of 10 of SPPWC for detectable warning details.
 - b. For station platforms, the truncated domes shall be aligned in a staggered pattern with a diameter of nominal 0.9 inch at the base tapering to 0.45 inch at the top and a height of nominal 0.2 inch. The truncated domes shall have a center-to-center spacing of nominal 1.67 inches diagonally and center-to-center spacing of nominal 2.35 inches. Refer to Figure 11B-23A -Truncated Dome of the current California Building Code, Title 24, Part 2, Section 1121B-Transportation Facilities.
 - c. In order to ensure a uniform appearance of the detectable warning surface throughout the transit system, equivalent facilitation findings or alternate patterns will not be acceptable.
3. Truncated dome pattern shall align properly from Tactile to Tactile.

E. Panel Configuration:

1. Standard Detectable Warning Tactile - Butt Joint, Staggered Truncated Domes: Nominal 24 inches x 48 inches x 3/8 inches thick with a 7/16 - inch thick deep flange along both four foot sides unless noted otherwise on the Contract Drawings. The perimeter of the standard panel features a chamfer (no 90 degree return).
2. The detectable warning tactile shall feature a butt joint detail from tactile to tactile. Alternatively a ship lap detail may also be furnished.

F. Fastener Holes in the Panel:

1. Holes for fasteners shall be formed in the factory. Holes for fasteners, whether made in the factory or in the field, shall be located only at the centers of the truncated domes.

- G. Tactiles comply with the following performance characteristics.

Property	ASTM Test	Nominal Value
Accelerated Weathering (3,000 Hours)	G26	Delta E maxd. of 20
Chemical Resistance	D1308	No Stain
Flexural Strength	D790	min. of 20,000psi
Compressive Strength	D695	min of 20,000psi
Tensile Strength	D638	min of 10,000psi
Gardner Impact Test	D5420	min. of 110 in-lb
Flame Spread	E84	FSI of less than 25 SDI of less than 150
Slip Resistance	C1028	min of 0.80
Wear Resistance	C501	min of 500
Water Absorption (2 weeks)	D570	Less than 0.20%
Salt Spray (120 hours)	B117	No Change

2.02 ACCESSORIES

- A. Fasteners for Concrete: Color matched nylon expansion sleeves with 1/4 inch diameter by 1-1/2 inches long stainless steel drive pins or as recommended by panel manufacturer for specific job conditions and accepted by the Engineer.
- B. Adhesive: Type approved by the panel manufacturer.
- C. Sealant: Urethane sealant of type approved by the panel manufacturer.
- D. Backer Rod: Acceptable to sealant manufacturer. Where required, such as, at platform expansion joints.

PART 3 - EXECUTION

3.01 INSTALLATION

- A. Apply adhesives, sealants and mechanical fasteners in strict accordance with the guidelines set by their respective manufacturers.
- B. Utilize manufacturer-provided template to lay out area to receive tactiles.
- C. Form recess for tactiles by either milling with diamond blade head or casting recess in place (at new paving) so that installed tactile will still flush relative to adjacent surface. Grind or form to the depth and width required by the approved shop drawings and manufacturer's instructions. Finish cast-in-place recess with equivalent of a light broom finish. When milled, substrate shall have a light ribbed finish.
- D. Contain and remove slurry resulting from concrete milling and sawcutting. Do not wash slurry into track bed area.

- E. For Tactiles with Recessed Flanges:
1. Utilize diamond bladed double headed wet saw to achieve parallel grooves to receive panels. Both sawcuts shall be made simultaneously from the same machine. Sawcut parallel to platform edge.
 2. After sawcutting, vacuum and power wash surface with clean clear water, free from all dirt and debris. Visually inspect surface for obtrusions or foreign matter. If obtrusions are present, remove by grinding. Remove foreign matter by grinding or further washing, as appropriate.
 3. Immediately prior to application of the setting adhesive, inspect surfaces to receive tactile to ensure that they are clean, dry, free of voids, curing compounds, projections, loose material, dust, oils, grease, sealers, and other contaminants. Verify that surfaces are structurally sound and that concrete has cured a minimum of 30 days. Obtain tactile manufacturer's representative's and Engineer's approval of surface preparation before installing panels.
- G. Set tactiles and install fasteners in accordance with tactile manufacturer's instructions and as follows:
1. Wherever possible, install full size (uncut) tactiles. Do not install tactile sections measuring less than 24 inches in length. Only cut tactiles where absolutely necessary.
 2. Maintain gap between tactiles for expansion and contraction in accordance with manufacturer's instructions.
 3. At platform expansion joints, cut tactiles on their short sides, finish cut edges smoothly, and lay tactiles with cut edges aligned with the edges of the substrate along the joints. Install fasteners on either side of the expansion joint at the time of initial installation. After a minimum of 4 hours, make a sawcut measuring 5/16 inch wide across the composite detectable warning tactile and fill with sealant. Make sawcut in the zone between truncated domes.
 - a. Where there is platform curvature, composite detectable warning tactiles shall be treated in a similar manner so that the joints remain uniform across the width of the joint between successive tactiles. However, in areas of platform curvature, the joint shall take on somewhat of a triangular configuration.
 4. Cutting through tactile domes shall be kept to a minimum. Where less than half of the truncated dome remains, grind off balance of dome; where over half of the truncated dome remains, feather dome so as not to present a tripping hazard.
- H. Install sealant in accordance with manufacturer recommendations.

3.02 CLEANING AND PROTECTING

- A. After the area has been fully tactiled and sealant system applied, clean panel surface, following the manufacturer recommended maintenance and cleaning procedures.
- B. Protect sealant and tactiles against damage during construction period. Comply with tactile and sealant manufacturers' recommendations.
- C. Protect tactiles against damage from rolling loads following installation by covering with plywood or hardwood.
- D. Clean tactile by method specified by manufacturer.

PART 4 – MEASUREMENT AND PAYMENT

4.01 MEASUREMENT

Tactile tile for platforms and ramps will be measured by the unit or fraction thereof furnished and completed in accordance with the Contract Documents and as measured by the Engineer. The quantities as contained on the Schedule of Quantities and Prices, or approved schedule of values, as applicable, as derived from the plans will be used as the basis for this measurement.

4.02 PAYMENT

Tactile tile for platforms and ramps furnished and completed in accordance with the Contract Documents will be paid for at the Contract Unit Price, as listed on the Schedule of Quantities and Prices. This price shall be full compensation for furnishing all labor, Materials, tools, equipment, supplies, supervision, and incidentals necessary for Handrails and Railing described by the Contract Documents.

END OF SECTION

SECTION 32 17 23

PAVEMENT STRIPING AND MARKING

PART 1 - GENERAL

1.01 SUMMARY

- A. Furnish all labor, materials and equipment necessary and incidental to applying pavement and platform striping and marking, and painting of curbs.
- B. Related Specification Sections include but are not necessarily limited to:
 - 1. Division 00 - Bidding Requirements, Contract Forms, and Conditions of the Contract.
 - 2. Division 01 - General Requirements.

1.02 REFERENCES

- A. Comply with the following Specifications, standards and recommended practices, except as otherwise indicated:
 - 1. Caltrans: State of California Department of Transportation, Standard Specifications, Section 84.
 - 2. Caltrans: State of California Department of Transportation, Traffic Manual; California Manual on Uniform Traffic Control Devices, latest edition.
 - 3. CCR, Title 24: California Code of Regulations: California State Building Code.

1.03 SUBMITTALS

- A. Submit the following in accordance with Division 01: Manufacturer's or supplier's certification that the materials delivered to the site are in compliance with the Specifications as specified in this Section.

1.04 QUALITY ASSURANCE

- A. Pavement stripings and markings for roadways shall be done by workers with proven skills required to perform the work in accordance with the correct location, alignment, and dimensions of the stripings and markings as shown in the Contract Drawings or as modified by the Engineer.

- B. At no additional cost to SCRRA, repair or replace pavement markings, which fail to present a uniform appearance and those, which are marred and damaged by traffic and by other causes.
- C. Until accepted by the Engineer, the Contractor must be responsible for the maintenance of all pavement stripings and markings until the roadway is open to vehicular traffic.
- D. All pavement striping and marking for roadways, whether temporary or permanent shall be completed before the roadway is opened for vehicular traffic.

PART 2 - PRODUCTS

2.01 MATERIALS

- A. Paint for traffic striping and markings shall comply with Caltrans Section 84-3. Type of paint shall either be Fast Dry or Rapid Dry solvent borne. Thermoplastic traffic stripes and pavement markings shall comply with Caltrans Section 84-2.

2.02 COLOR

- A. Color for roadways shall be California State Specifications "white" and "yellow" unless otherwise indicated in the plans.
- B. Painting of curbs shall use the color indicated in the Contract Drawings.

PART 3 - EXECUTION

3.01 GENERAL

- A. Apply paint by using a striping machine, except for special areas and markings, which are inaccessible or not adaptable to machine application, in which case hand application will be permitted with approved masking or stencil use.
- B. The striping machine shall be an approved spray-type marking machine capable of producing the specified dimensions of the markings and stripings with clear-cut edges and uniform smooth film thickness.
- C. The minimum wet film thickness of the paint shall be 15 mils or in accordance with the manufacturer's recommendation and approved by the Engineer.
- D. Application of the paint shall be made only on a dry and clean surface free from grease, oils, dirt, curing compound or any other foreign matter, when the weather is not windy and humid, and the ambient air temperature is not less than 40 DegF. Contractor must not apply paint to uncured concrete.
- E. Contractor must clean up all over spray with approved Materials and leave a clean and complete project.

PART 4 - MEASUREMENT AND PAYMENT

4.01 MEASUREMENT

- A. Pavement striping and marking will be measured by the unit or fraction thereof furnished and placed in accordance with the Contract Documents and as measured by the Engineer. The quantities as contained on the Schedule of Quantities and Prices, or approved Schedule of Values as derived from the plans will be used as the basis for this measurement.

4.02 PAYMENT

- A. Pavement striping and marking completed in accordance with the Contract Documents will be paid for at the contract unit price, as listed in the Schedule of Quantities and Pricing. This price shall be full compensation for furnishing all labor, materials, tools, equipment, supplies, supervision, and incidentals necessary for pavement striping and marking described by the Contract Documents.

END OF SECTION

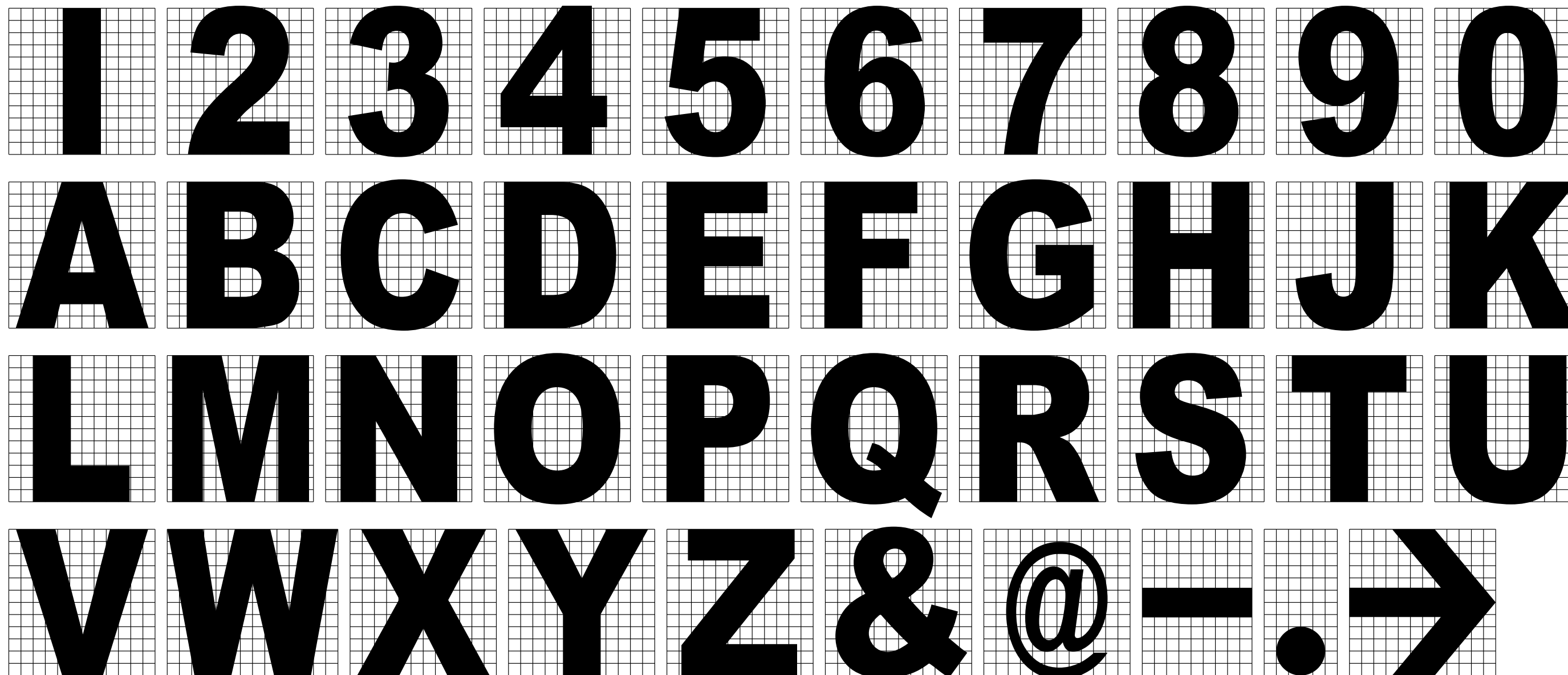

TEXT HEIGHT
TEXT HEIGHT X 1/2
TEXT HEIGHT
TEXT HEIGHT X 1.5

**TEXT
SPACING**

UNRELATED LINE

NOTES:

1. "ARIAL BOLD" LETTERS AND NUMERALS SHALL BE USED ON ALL SIGNS UNLESS OTHERWISE SPECIFIED ON SIGN STANDARD.
2. LETTERS AND NUMERALS MAY BE MADE PROPORTIONALLY NARROWER THAN ILLUSTRATED IF NEEDED TO FIT AVAILABLE SPACE ON THE SIGN. HEIGHT SHALL NOT BE ADJUSTED.
3. ALL LETTERS AND NUMERALS SHALL BE BLACK 3M 3650-12 "SCOTCH PLUS" NON-REFLECTIVE.
4. THE LETTER "I" AND THE NUMERAL "1" ARE IDENTICAL.
5. USE TEXT SPACING PATTERN ON THIS SHEET UNLESS OTHERWISE SPECIFIED ON SIGN STANDARD.

DRAWN BY: A. CARLOS DATE: 03/31/2011		<small>SCRR ENGINEERING STANDARDS ARE INTENDED FOR SCRR APPROVED USES ONLY. FOR NON-SCRR APPROVED USES, SCRR SHALL NOT BE RESPONSIBLE FOR THE ACCURACY OR COMPLETENESS OF THE DATA OR INFORMATION CONTAINED HEREIN. THE SELECTION AND USE OF THESE STANDARDS IS THE SOLE RESPONSIBILITY OF THE USER AND SHOULD NOT BE USED WITHOUT CONSULTING A REGISTERED PROFESSIONAL ENGINEER. ALL WARRANTIES AND REPRESENTATIONS OF ANY KIND ARE DISCLAIMED. ANYONE MAKING USE OF THIS INFORMATION AGREES THAT IT ASSUMES ALL LIABILITY ARISING FROM SUCH USE. NO PART OF THESE STANDARDS SHOULD BE REPRODUCED OR DISTRIBUTED IN ANY FORM OR BY ANY MEANS WITHOUT THE PRIOR WRITTEN PERMISSION OF SCRR. ALL RIGHTS RESERVED.</small>	 <p>SOUTHERN CALIFORNIA REGIONAL RAIL AUTHORITY ONE GATEWAY PLAZA, 12TH FLOOR, L. A., CA. 90012</p>	ENGINEERING STANDARDS	STANDARD 1212
ASSISTANT DIRECTOR: STANDARDS & DESIGN <i>Narek D. Bibe</i> DIRECTOR OF ENGINEERING AND CONSTRUCTION <i>William Davan</i>				LETTERING FOR SIGNS	SCALE: NONE
REV.	DATE	DESCRIPTION	DES.	ENG.	REVISION SHEET 1 OF 1



Southern California Regional Rail Authority

APPLICATION FOR RIGHT-OF-WAY ENCHROACHMENT

Application Date:

SCRRRA File and Project Number:

SECTION 1: PROJECT OWNER INFORMATION TO BE COMPLETED BY APPLICANT

Project Owner/Legal Company Identification (required)			
Owner's Complete Legal Company Name:			
Legal Address (1):			
Legal Address (2):			
City:	State:	Zip:	
Business Type:	<input type="checkbox"/> Corporation	<input type="checkbox"/> Limited Liability Company	<input type="checkbox"/> Partnership
	<input type="checkbox"/> Municipality	<input type="checkbox"/> Limited Liability Partnership	<input type="checkbox"/> Joint Venture
State of Incorporation:	Other Business Type - Describe:		
Billing Address			
<input type="checkbox"/> (Check box if same as above); if not, please complete below.			
Billing Address (1):			
Billing Address (2):			
City:	State:	Zip:	
Project Owner Contact Information			
Contact Name:	Contact Title:		
Office Phone:	Ext.:	Mobile Phone:	
Email:	Emergency Phone:		

SECTION 2: PROJECT CONTACT INFORMATION TO BE COMPLETED BY APPLICANT

Project Engineer/Consultant/Agent Information			
Engineer/Consultant/Agent Company Name:			
Contact Name:			
Mailing Address:			
City:	State:	Zip:	
Office Phone:	Mobile Phone:		
Email:			

Application for Right-of-Way Encroachment

SECTION 3: PROJECT INFORMATION/LOCATION	TO BE COMPLETED BY APPLICANT
Project Reference	
<p>Is the current work connected to an existing agreement, license, or easement between SCRRA, a Member Agency, or a prior Railroad</p> <p><input type="checkbox"/> Yes Provide Agreement # or Title and Date:</p> <p><input type="checkbox"/> No</p>	
<p>Is this project related to another project or activity involving SCRRA or to which SCRRA is a party?</p> <p><input type="checkbox"/> Yes Describe:</p> <p><input type="checkbox"/> No</p>	
<p>Provide utility owner project reference number: <input style="width: 100%;" type="text"/></p>	
Project Scope	
<p>Check box to indicate type of entry request:</p> <p>General Access:</p> <p><input type="checkbox"/> Bridge Inspection (if checked, must include DOT Bridge Numbers)</p> <p><input type="checkbox"/> Field Review of Proposed Improvements</p> <p><input type="checkbox"/> Utility Location</p> <p><input type="checkbox"/> Monitoring (Vibration, Structural, etc)</p> <p><input type="checkbox"/> Construction Job Walk</p> <p><input type="checkbox"/> Surveying</p> <p><input type="checkbox"/> Film Shooting</p> <p>Fiber Optic, Petroleum or Gas Pipeline Access or Investigation:</p> <p><input type="checkbox"/> Annual Maintenance Permit</p> <p><input type="checkbox"/> Relocation of Existing Utility</p> <p><input type="checkbox"/> Protection of Existing Utility</p> <p><input type="checkbox"/> Potholing of Existing Utilities</p> <p><input type="checkbox"/> Other</p> <p>Environmental Investigation:</p> <p><input type="checkbox"/> Groundwater Sampling</p> <p><input type="checkbox"/> Sediment Sampling</p> <p><input type="checkbox"/> Soil Sampling</p> <p><input type="checkbox"/> Remediation</p> <p><input type="checkbox"/> Monitoring Wells</p> <p>If state or Federal Site, provide Site #:</p> <p>Construction of New Pipeline or Underground Conduit (See Section 4)</p> <p><input type="checkbox"/> Construct Storm Drain or Sanitary Sewer</p> <p><input type="checkbox"/> Construct Petroleum or Gas Pipeline</p> <p><input type="checkbox"/> Construct New Fiber Optic Facilities</p> <p><input type="checkbox"/> Construct New Underground Power Line</p> <p><input type="checkbox"/> Construct Underground Cable not Otherwise Described Above</p> <p><input type="checkbox"/> Other Pipeline or Underground Conduit</p> <p>Railroad Operations:</p> <p>How close will the proposed activity be to the nearest railroad track:</p> <p>Will the proposed activity require crossing railroad track(s):</p> <p><input type="checkbox"/> Yes Describe: <input style="width: 100%;" type="text"/></p> <p><input type="checkbox"/> No</p>	

Application for Right-of-Way Encroachment

SECTION 3: PROJECT INFORMATION/LOCATION		TO BE COMPLETED BY APPLICANT	
Project Description			
Description / Scope <i>(Include: purpose, scope of work, materials, equipment, geographic features, special conditions):</i>			
Project Location			
City:		County:	State:
Street Address (if applicable):			
Subdivison:		Mile Post:	

Application for Right-of-Way Encroachment

SECTION 4: UNDERGROUND STRUCTURE INFORMATION	TO BE COMPLETED BY APPLICANT	
Carrier Pipe: <input type="checkbox"/> New Construction <input type="checkbox"/> Reconstruction		
Non-Flammable Substance: <input type="checkbox"/> (See SCRRRA Standard ES 5001)		
Flammable Substance: <input type="checkbox"/> (See SCRRRA Standard ES 5002)		
Nearest Cross Streets:		
Angle of Crossing with Track:		
Pipe Slope or Gradient:		
	Carrier Pipe	Casing Pipe
Content to be Handled		
Nominal Diameter		
Pipe Material		
Specifications and Grade		
Wall Thickness		
Operating Pressure/Maximum Pressure		
Minimum Yield Strength		
Type Joints		
Coating Material		
Length of Casing		
Longitudinal Distance from Centerline of Track		
Distance from Centerline of Track		
Base of Rail to Top of Casing		
Roadway Ditches		
Vents: <input style="width: 100px;" type="text"/>	Depth: <input style="width: 100px;" type="text"/>	
Method of Installation: <input type="checkbox"/> Dry Bore <input type="checkbox"/> Directional Bore		

Application for Right-of-Way Encroachment

SECTION 4: UNDERGROUND STRUCTURE INFORMATION		TO BE COMPLETED BY APPLICANT
Type, Size, and Spacing of Insulator Supports	<input type="text"/>	
Distance to Shut-off Valve on Each Side of R/W	<input type="text"/>	
Types of Seals at Ends of Crossings	<input type="text"/>	
Cathodic Protection (Type)	<input type="text"/>	
Casing Filler	<input type="text"/>	
Longitudinal Pipeline: Distance from Centerline of Outside Track	<input type="text"/>	
Depth of Bury to Top of Pipe	<input type="text"/>	

Application for Right-of-Way Encroachment

SECTION 5: OVERHEAD STRUCTURE INFORMATION	TO BE COMPLETED BY APPLICANT
<input type="checkbox"/> New Construction <input type="checkbox"/> Reconstruction <input type="checkbox"/> Communication Line Crossing <input type="checkbox"/> Power Line Crossing	
Existing Facility	
<input type="checkbox"/> Communication Line <input type="checkbox"/> Supply (Electrical) Line Height Above Top of Rail in (ft): Supply: <input style="width: 50px;" type="text"/> Communication: <input style="width: 50px;" type="text"/>	
General	
Angle of Crossing with Tracks: <input style="width: 50px;" type="text"/> Length of Span (ft) <input style="width: 50px;" type="text"/> Height Above Top of Rail (ft, No Wind, 60 deg) <input style="width: 50px;" type="text"/>	
Poles	
<input type="checkbox"/> Existing <input type="checkbox"/> New Length of Pole (ft) <input style="width: 50px;" type="text"/> Circumference of Top of Pole (in) <input style="width: 50px;" type="text"/> Location of Pole with Respect to R/W (ft) <input style="width: 50px;" type="text"/> Pole Inside of R/W (ft): Left <input style="width: 30px;" type="text"/> Right <input style="width: 30px;" type="text"/> Pole Outside of R/W (ft): Left <input style="width: 30px;" type="text"/> Right <input style="width: 30px;" type="text"/> Depth of Pole Below Ground surface (ft, Min 5') <input style="width: 50px;" type="text"/>	
Cable	
Type <input style="width: 80px;" type="text"/> Number <input style="width: 30px;" type="text"/> Size <input style="width: 30px;" type="text"/> Voltage <input style="width: 80px;" type="text"/> Phase <input style="width: 30px;" type="text"/> Frequency <input style="width: 30px;" type="text"/> Fiber Optic Cable -Type: <input style="width: 80px;" type="text"/> Number <input style="width: 30px;" type="text"/>	



SITE SPECIFIC WORK PLAN (SSWP)

**SITE SPECIFIC WORK PLAN (SSWP)
SCOPE OF SSWP**

All SSWPs shall be submitted in writing a minimum of 15 calendar days prior to the scheduled start of work within the SCRRRA right-of-way. SCRRRA will require a SSWP for all proposed work in or adjacent to SCRRRA right-of-way that affects the operation and safety of Metrolink passengers and trains. Provide detailed information on each task for SCRRRA review and approval. A SSWP Checklist shall be submitted to SCRRRA.

TASK	DESCRIPTION
Contractor	Provide the name and address of the contractor.
Scope	Provide a brief description of the work. Description shall include all activities necessary to perform construction task within SCRRRA right-of-way, including use of grade crossings, main tracks, siding, stations, and proposed storage area.
Brief Schedule	List the project beginning and end dates, as well as time for the proposed activities.
Location	Identify the city, county, subdivision name, mile post limits, tracks, sidings of the proposed work activity.
Equipments	Identification of all equipment necessary for the successful completion of the work activities. All equipment shall be inspected, calibrated, and certified by the contractor for performing work in and around SCRRRA right-of-way. Provide plan illustrating locations of equipment during build-up of equipment.
Material and Staging	Identify all materials required for the completion of the work activity. Identify the placement of all personnel and material to allow for schedule adherence. Identify proposed haul roads, methods of separating construction vehicles from railroad operations, truck staging locations. Provide crane capacity, locations and positions during hoisting.
Schedule	Detailed summary of the work activity. All work with a potential to impact normal functioning of any part of the operating system shall include a detailed schedule of events indicating the expected hourly progress of each activity that has duration of one hour or longer. The schedule shall include a time at which all activities planned will be completed. Failure of the contractor to complete the scheduled activities by the planned time or to put in place an approved contingency plan may adversely impact the operations of SCRRRA.
Haul Routes	Identify the routes that will be used by the trucks to deliver materials. Contractor will communicate with sub-contractors the safety of the railroad and adherence to safety procedures while delivering materials to the right-of-way.
Safety Plan	Identification of proper personnel protective equipment (PPE) and work area. Provide plan for safety training, utility notifications, work windows, and measures to perform work activities to effectively reduce the amount of time and effort required during the approved work windows identified and submitted.
Contingency Plan	Include back-up or contingency plans for putting the system back in operation in case of emergency or in case the contractor fails to perform



SITE SPECIFIC WORK PLAN (SSWP)

	and complete the work on time. Contingency plan shall address the various stages of construction.
Worksite Representative	Names, title, phones (office and cellular), e-mail address and date and time of availability.
Emergency Response Plan	Written procedures for responding to emergencies (phones, contact numbers, addresses and maps) for incident, police, ambulance, fire and medical (hospitals). Provide First-aid kit and fire extinguisher at the field location. Name, title and phones (office and cellular) of all responsible persons who can be contacted for emergency.
Excavation Plan (If necessary)	Provide excavation support plans and calculations. Excavation plans shall meet Caltrans, OSHA, and SCRRRA requirements. Refer to SCRRRA's Excavation Support Guidelines.
Boring and Jacking Plan (If necessary)	Provide plans and profile of casing and carrier pipes. Provide details and calculations of boring and excavation. Soil boring data and analysis, track monitoring plans and pressure grouting plans shall be submitted. Refer to SCRRRA's Engineering Standard ES5001 or ES5002.
Drilling and Pile Driving Plan (If necessary)	Provide plans of pile layout and developed elevation of finished structures.
Falsework Plan (If necessary)	Provide falsework installation, stripping and lowering plans and calculations for review and approval.
Temporary Traffic Control Plan (If necessary)	Submit temporary traffic control plans for any traffic control affecting grade crossings and disrupting normal operation of grade crossing protection. Temporary Traffic control plans shall meet CA MUTCD, WATCH and SCRRRA requirements. Refer to SCRRRA Temporary Traffic Control Guidelines and SCRRRA Engineering Standard ES4301.



SITE SPECIFIC WORK PLAN (SSWP)

SITE SPECIFIC WORK PLAN (SSWP)
CHECKLIST

ITEM	YES	NO	N/A	IF NO, EXPLAIN
Equipment				
All equipment necessary for the work is identified?				
Procedures for all equipments to be inspected, calibrated and certified established?				
Material and Staging				
Materials required for work identified?				
Personnel required for work identified?				
Plan illustrating locations of materials and equipment during build-up of equipment and prior to hoisting submitted?				
Plan illustrating crane capacity, locations and positions during hoisting submitted?				
Schedule				
A schedule of the work, showing each activity and where and how it affects normal operation submitted?				
Detailed schedule indicating the expected hourly progress of each activity that has duration of one hour or longer submitted?				
All SCRRA furnished services and time line identified on the schedule?				
Haul Routes				
Routes used by the trucks to deliver materials identified?				
Sub-contractors are communicated with haul routes, safety of the railroad and safety procedures while delivering materials to the right-of-way?				
Truck staging locations identified?				
Safety Plan				
Proper personnel protective equipment (PPE) identified?				
Safety training scheduled and completed?				
SCRRA signal and communication cables located? Ticket number obtained?				
DigAlert ticket number obtained for the project?				
Work windows are identified for the constructions?				
Measures to perform work activities to effectively reduce the amount of time and effort required during the approved work windows identified and submitted?				
Worksite hazards identified?				
Contingency Plan				
Back-up or contingency plan and necessary resources (labor, equipment, materials) to assure that all appropriate measures are available for the return to full service submitted?				
Contingency plan addresses the various stages of work?				
Worksite Representatives				
Name, title, phones (office and cellular), e-mail address,				



SITE SPECIFIC WORK PLAN (SSWP)

date and time of availability provided to SCRRA?				
Emergency Response Plan				
Written procedures for responding to emergencies for incident, police, ambulance, fire and medical (hospital) submitted?				
First-aid kit and fire extinguisher will be located at field location?				
Name, title and phones (office and cellular) of all responsible persons who can be contacted for emergency provided?				
Excavation Plans (If necessary)				
Limits of excavation with slope lines indicated?				
Excavation support plans including calculations submitted?				
Type and models of equipment proposed for use submitted?				
Operational limits of equipment (including swing radius or overhang distance submitted?				
Plan and elevation illustrating location of equipment with respect to track submitted?				
Stock pile areas?				
SCRRA Shoring Submittal Design Checklist as per SCRRA Excavation Support Guidelines, Appendix A submitted?				
SCRRA Shoring Submittal Review Checklist as per SCRRA Excavation Support Guidelines, Appendix B submitted?				
Boring and Jacking Plans (If necessary)				
Plan and profile of casing and carrier pipe submitted?				
Location and size of jacking and receiving pits shown?				
Engineering details and calculations submitted?				
Soil boring data and analysis submitted for pipes equal or greater than 48" in diameter?				
Track monitoring plans submitted for pipes equal or greater than 48" in diameter as per Section 9, Track Monitoring of SCRRA Excavation Support Guidelines?				
Boring, tunneling or jacking operation will be continuous without stoppage when the casing is 20 feet from the nearest track?				
Immediately after completion of jacking operation, the installation shall be pressure grouted?				
Boring and Jacking meet SCRRA Engineering Standard ES5001 or ES5002 requirements?				
Drilling and Pile Driving Plans (If necessary)				
Plan of pile layout and developed elevation of finished structure with intermediate excavation levels indicated?				
Type, model, location, operation limits of cranes submitted to SCRRA?				
Pick plan for hoisting of large or heavy materials submitted?				
Falsework Plan (If necessary)				
Plans of falsework and calculations submitted?				
Falsework erection plans submitted?				
Plans of stripping and lowering of falsework including schedule submitted?				



METROLINK

SITE SPECIFIC WORK PLAN (SSWP)

Methods of securing beams and stringers to bents submitted?				
SCRRRA Falsework Submittal Checklist as per SCRRRA Grade Separation Guidelines submitted?				
Temporary Traffic Control Plans (If necessary)				
Temporary traffic control plans submitted?				
Approval of Temporary traffic control plan obtained from local authority?				
Temporary traffic control plan meet CA MUTCD, WATCH and SCRRRA requirements?				
Temporary traffic control plan meet SCRRRA guidelines and Engineering Standard ES4301 requirements?				



**INDEMNIFICATION
and
ASSUMPTION OF LIABILITY AGREEMENT**

SCRRA FORM NO. 5

SCRRA File No.	
SCRRA Project/Task No.	
Subdivision	
Mile Post	

The Contractor, hereby requests permission to encroach onto the Southern California Regional Rail Authority (SCRRA) and Member Agency Right-of-Way.

- Location of Work: _____
- Purpose/Description: _____

1. Definitions

- A. Contractor is an individual, firm, partnership or corporation, or combination thereof, private, municipal or public, including joint ventures, which are referred to throughout this document by singular number and masculine gender. For purposes of this agreement, Contractor also includes any subcontractor, supplier, agent or other individual entering the Right-of-Way during performance of work.
- B. Indemnitees are SCRRA, Member Agencies, and Operating Railroad, and their respective officers, commissioners, employees, agents, successors and assigns.
- C. Operating Railroad is/are any passenger or freight-related railroad company(s) validly operating on SCRRA and Member Agency track(s). Operating Railroads are any combination(s) of the National Railroad Passenger Corporation, (AMTRAK) the Union Pacific Railroad Company, (UPRR) and the BNSF Railway Corporation. (BNSF)
- D. Right-of-Way is defined herein to mean the real and/or personal property of SCRRA and/or Member Agencies.
- E. SCRRA is a five-county joint powers authority, created pursuant to State of California Public Utilities Code Section 130255 and California Government Code Section 6500 et seq., to build and operate the "Metrolink" commuter train system in the five-county area on rail rights-of-ways owned by the Member Agencies. The five-county Member Agencies are comprised of the following: Los Angeles County Metropolitan Transportation Authority (MTA), Ventura County Transportation Commission (VCTC), Orange County Transportation Authority (OCTA), San Bernardino County Transportation Authority (SBCTA), and Riverside County Transportation Commission (RCTC).
- F. SCRRA Employee-In-Charge (EIC) is a Southern California Regional Rail Authority employee or contractor (SCRRA General Code of Operating Rules and Territory Qualified) providing warning to Public Agency or Contractor personnel of approaching trains or on track equipment and who has the authority to halt work and to remove personnel from the Right-of-Way to assure safe work.



G. SCRRRA Safety Trainer is a qualified SCRRRA employee or contracted employee (SCRRRA General Code of Operating Rules qualified) as authorized by the SCRRRA Director of Engineering and Construction to provide Contractor training.

2. **Entry onto Right-of-Way**

No verbal approvals will be granted. A fully executed copy of this Form 5 must be in the possession of the Contractor at the encroachment site and must be produced upon request by SCRRRA or Member Agency's representative. If said Agreement is not produced, SCRRRA has the right to delay access to the Right-of-Way until the Contractor demonstrates possession of the Form 5. SCRRRA EIC must be present whenever the Contractor enters into the Right-of-Way. SCRRRA will also provide additional personnel and equipment for protection deemed necessary by SCRRRA. SCRRRA may authorize encroachment onto the Right-of-Way without presence of an EIC depending on the nature and location of the encroachment. SCRRRA involvement in providing positive protection shall not relieve the Contractor from its complete responsibility for the adequacy and safety of its operation. The Contractor shall furnish information so that SCRRRA can take all precautionary safety measures. If, for any reason, it is necessary to change the time and/or date when encroachment is required, the Contractor shall contact SCRRRA's ROW Encroachments Administrator and not enter the Right-of-Way until it has been approved in writing and appropriate safety protection can be rescheduled.

3. **Termination of Agreement**

SCRRRA or Member Agency reserves the right to terminate or revoke this Agreement at any time upon two hours notice; however, in the event of an unsafe condition on the Right-of-Way, SCRRRA shall have the right to terminate this Agreement immediately, without any advanced notice. Unless subsequently modified, extended, terminated or revoked by SCRRRA, this temporary Agreement shall extend until access to the Right-of-Way is no longer necessary. The Contractor agrees to notify SCRRRA, in writing, when work is completed. The Contractor shall also complete and return the Confirmation of Completion form.

At the request of SCRRRA or Member Agency, Contractor shall remove from the Right-of-Way any employee or other individual who fails to conform to the instructions of SCRRRA's or Member Agency's representative. Any right of Contractor to enter upon the Right-of-Way shall be suspended until such request of SCRRRA or Member Agency is met. Contractor shall defend, indemnify and hold harmless SCRRRA and Member Agency against any claim arising from the removal of any such employee or other individual from the Right-of-Way.

4. **Indemnification**

Contractor, on behalf of itself and its employees, subcontractors, agents, successors, and assigns, agrees to indemnify, defend, by counsel satisfactory to SCRRRA and Member Agency, and hold harmless "Indemnitees", and each of them to the maximum extent allowed by law, from and against all loss, liability, claims, demands, suits, liens, claims of lien, damages (including incidental consequential damages), costs and expenses (including, without limitation, any fines, penalties, judgments, actual litigation expenses, and experts' and actual attorneys' fees), that are incurred by or asserted against Indemnitees arising out of or connected in any manner with (i) the acts or omissions of the Contractor, or its officers, directors, affiliates, subcontractors or agents or anyone directly or indirectly employed by them or for whose acts the foregoing persons are liable (collectively, "Personnel") in connection with or arising from the presence upon or performance of activities by the Contractor or its Personnel with respect to the Right-of-Way, (ii) bodily and/or personal injury or death of any person (including without limitation employees of Indemnitees) or damage to or loss of use of Right-of-Way resulting from such acts or omissions of the Contractor or its Personnel, or (iii)



non-performance or breach by Contractor or its Personnel of any term or condition of this Agreement, in each case whether occurring during the term of this Agreement or thereafter.

The foregoing indemnity shall be effective regardless of any negligence (whether active, passive, derivative, joint, concurrent or comparative) on the part of Indemnitees, unless caused by the sole negligence or willful misconduct of Indemnitees, and is in addition to any other rights or remedies, which Indemnitees may have under the law or under this Agreement.

Claims against the Indemnitees by the Contractor or its Personnel shall not limit the Contractor's indemnification obligations hereunder in any way, whether or not such claims against Indemnitees may result in any limitation of the amount or type of damages, compensation, or benefits payable by or for the Contractor or its Personnel under workers' compensation acts, disability benefit acts or other employee benefit acts or insurance.

The provisions of this section shall survive the termination or expiration of the Agreement.

5. **Assumption of Liability**

To the maximum extent allowed by law, the Contractor releases Indemnitees from and assumes any and all risk of loss, damage or injury of any kind to any person or property, including without limitation, the Right-of-Way and any other property of, or under the control or custody of, the Contractor or its personnel in connection with any acts undertaken under or in connection with this Agreement. The Contractor's assumption of risk shall include, without limitation, loss or damage caused by defects in any structure or improvements (including easement, lease or license agreements for other existing improvements and utilities) on the Right-of-Way, accident or fire or other casualty on the Right-of-Way, or electrical discharge, noise or vibration resulting from SCRRRA, Member Agency, and Operating Railroad transit operations on or near the Right-of-Way and any other persons or companies employed, retained or engaged by SCRRRA or Member Agency. The Contractor, on behalf of itself and its Personnel (as defined in Section 4, "Indemnification") as a material part of the consideration for this Agreement, hereby waives all claims and demands against the Indemnitees for any such loss, damage or injury of the Contractor and/or its Personnel. The Contractor waives the benefit of California Civil Code Section 1542, which provides as follows: "A general release does not extend to claims which the creditor does not know or suspect to exist in his favor at the time of executing the release, which if known by him must have materially affected his settlement with the debtor."

The provisions of this Section shall survive the termination or expiration of this Agreement.

6. **Reimbursement of Costs and Expenditures**

The Contractor agrees to reimburse SCRRRA or any Member Agency and/or any Operating Railroad for all cost and expense incurred by SCRRRA or Member Agency in connection with work and safety services, including without limitation the expense of engineering plan review, administrative costs to process approvals and agreements, annual overhead rates, safety training, utility markings, and SCRRRA EIC and protective services as SCRRRA deems necessary. Contractor agrees to reimburse SCRRRA for all work related services including but not limited to installation and removal of falsework beneath tracks, restoration of railroad roadbed and tracks, installation of appropriate protective devices, temporary and permanent repairs of signal or communication equipment, restoration of the Right-of-Way to a condition satisfactory to SCRRRA's and Member Agency's representative.



The Contractor agrees to reimburse SCRRA or any Member Agency actual cost and expense incurred. This includes cost of plan review, administrative, safety training, utility marking, flagging services fees, and work performed in connection with said work, including applicable overhead rates. Refer to SCRRA's Schedule of Fees for more information. SCRRA will charge the Contractor four hours minimum for the mandatory safety training class and for other services four hours or less in duration. SCRRA will charge the Contractor for eight hours minimum if the Contractor cancels SCRRA services after SCRRA EIC or SCRRA Safety Training Officer is on site on the day of the appointment.

The Contractor also agrees to reimburse SCRRA, any Member Agency and/or any Operating Railroad for any and all cost and expense incurred as a result of Contractor's work which may result in (i) unscheduled delay to the trains or interference in any manner with the operation of trains, (ii) unscheduled disruption to normal train operation, (iii) unreasonable inconvenience to the public or private user of the system, (iv) loss of revenue and (v) alternative method of transportation for passengers. SCRRA will submit final bills to the Contractor for cost incurred.

SCRRA will provide the cost of all SCRRA services based on Contractor's input. Prior to commencement of work, the Contractor shall provide deposit representing the estimated expense to be incurred by SCRRA and Member Agency in connection with said work. As the work progresses, SCRRA may require additional progress payments as the scope of work changes or becomes clearer. SCRRA may discontinue services to Contractor pending receipt of progress payments. The deposit and progress payments shall be applied to SCRRA's and Member Agency's actual costs and expenditures. The Contractor shall be responsible to pay any amount exceeding the above payments upon receipt of notice or invoice by SCRRA. SCRRA shall exercise its best efforts to provide final invoicing to Contractor within 90 days following completion of the work; however, Contractor acknowledges that it shall be responsible for payment of all expenses incurred by SCRRA and Member Agency in connection with the work even if the final invoicing is provided to Contractor thereafter. Upon completion of all work, any payments in excess of SCRRA's and Member Agency's costs and expenditures shall be returned to the Contractor within a reasonable time.

If the Contractor stop the work in the right-of-way for three months or longer and then plans to resume the work, he/she shall notify SCRRA as per contact information shown in Section 10 below prior to resumption of the work.

7. **Safety and Protective/Flagging Services Notification**

The Contractor and his subcontractors shall be required to attend a SCRRA Basic Right-of-Way Safety Training Class prior to receiving permission to enter the Right-of-Way. Upon completion of safety training and prior to start of work activities, the Contractor shall notify SCRRA's consultant/contractor, to schedule (EIC) Flagging Services. SCRRA has two contractors who provided SCRRA Basic Right-of-way Safety Training and (EIC) Flagging Services, based on Subdivision.

JACOBS ENGINEERING Provides Safety Training and (EIC) Flagging for the following Subdivisions:

Orange

Olive

San Gabriel (this includes the Redlands branch)

Perris Valley Line (including the Riverside layover if necessary)

Pasadena

Rialto

Shortway



To schedule Safety Training call Mr. Trevor Williams with Jacobs Engineering at (714) 659-1141. Request safety training at least 72 hours in advance of requested training date. To schedule (EIC) Flagging please reach out to Mr. Dale Stuart with Jacobs Engineering at (213) 305-8424 a minimum of fifteen (15) working days prior to beginning work on the Right-of-Way and secure any safety EIC services SCRRA deems necessary. This prior notification does not guarantee the availability of on-track safety protection for the proposed date of work. In no event shall SCRRA be liable to Contractor in the event that track safety protection cannot be provided due to force majeure event or for any other reason. SCRRA will advise Contractor as soon as reasonably practicable once it is determined that track safety protection will be unavailable on a proposed date of construction.

RAILPROS Provides Safety Training and (EIC) Flagging for the following Subdivisions:

**Montalvo
Ventura
Valley
River**

To schedule Safety Training call Mr. Chris Nunez with Railpros Engineering at (909) 816-0852. Request safety training at least 72 hours in advance of requested training date. To schedule (EIC) Flagging please reach out to Mr. Darrin Pock with Railpros Engineering at (909) 706-5280 a minimum of fifteen (15) working days prior to beginning work on the Right-of-Way and secure any safety EIC services SCRRA deems necessary. This prior notification does not guarantee the availability of on-track safety protection for the proposed date of work. In no event shall SCRRA be liable to Contractor in the event that track safety protection cannot be provided due to force majeure event or for any other reason. SCRRA will advise Contractor as soon as reasonably practicable once it is determined that track safety protection will be unavailable on a proposed date of construction.

8. **Emergency Telephone Numbers**

The Contractor must immediately contact SCRRA in case of accidents, personal injury, defect in track, bridge or signals, or any unusual condition that may affect the safe operation of the railroads. The following are SCRRA's emergency numbers:

Signal Emergencies and Grade Crossing Problems	(888) 446-9721
Metrolink Chief Dispatcher	(909) 596-3584 or (888) 446-9715
Metrolink Sheriff's Dispatcher	(323) 563-5280
Signal and Communications Cable Location	(909) 592-1346

9. **California Law/Venue**

This agreement shall be construed and interpreted in accordance with and governed by the laws of the State of California. Venue shall be located in courts in Los Angeles County.

10. **SCRRA Contact**

All information and documents shall be submitted to the following:

Southern California Regional Rail Authority (SCRRA)
2558 Supply Street
Pomona, California 91767
Attn: Mr. Christos Sourmelis - ROW Encroachments Coordinator
Email: sourmelisc@scrra.net
(909) 392-8463



The Contractor hereby agrees to the terms as set forth in this Agreement, and hereby acknowledges receipt of this Agreement.

(Name of Applicant)

(Signature)

(Address)

(Print Name)

(Title)

(Telephone)

(Applicant's State License No.)

(Fax)

(Email)

Receipt of the foregoing agreement is hereby acknowledged on this _____ day of _____ 20____

By: _____
ROW Encroachments Coordinator

By: _____
Principal Engineer, Project Delivery

[Approved as To Form By Legal Counsel]



TEMPORARY OCCUPANCY PROCESS INSTRUCTIONS

Licensing Process:

IMPORTANT: If you require a Temporary Occupancy permit, submit all paperwork to JLL.

If you require access to BNSF Railway Company's property for a Seismic Survey you must first enter into a Lease Agreement.

Please contact: Jennifer Kindred Phone: (918) 895-8037
Farmers National Company
5110 S. Yale
Suite 400
Tulsa, OK 74135
jkindred@farmersnational.com

After submitting a Lease Agreement with your application package Jones Lang LaSalle Brokerage, Inc. (JLL) will review the area to determine ownership of mineral rights and forward to the local BNSF Roadmaster for approval.

1. Once application package is received by (JLL), and all prior approvals have been obtained, if required, the application and drawing will be forwarded to the engineering firm to prepare the Exhibit "A" drawings for the contract. **This process takes approximately 10 to 15 working days.**
2. When the Exhibit "A" is completed, a contract will be prepared and two (2) copies will be forwarded to you for an original signature. **A letter will be sent to you that will provide directions regarding insurance and any additional fees.**
3. Return the signed contracts (2 contracts with original signatures), along with the appropriate **payment** to JLL's Permit Department.
4. The final contracts, with original signatures, are presented for execution provided payment has been received and insurance has been approved.
5. Once the contract is executed, one original will be returned to you for your files.
6. Prior to commencing any work on the Premises, Licensee shall complete and shall require its contractor (all parties who will be working on the site) to complete the safety orientation program at Internet Website <http://bnsfcontractor.com/>. This orientation must be completed no more than one year in advance of Licensee's entry on the Premises.
7. The cover letter and the executed contract will list the Roadmaster's name and phone number. **You will need to contact the Roadmaster or Wilson & Company ten (10) days prior to beginning work. The contact information will be provided to you when you receive your fully executed contract**

Process Time:

Please be advised that the average time period for completion of this process is 4 weeks from the time that the application is received. Every effort will be made to complete this process in a timely manner.

Insurance Requirements for the following Agreement:

	Temporary Occupancy
Commercial General Liability Insurance	Contractual Liability with a combined single limit of a minimum of \$2,000,000 each occurrence and an aggregate limit of at least \$4,000,000.
Business Automobile Insurance	Combined single limit of at least \$1,000,000 per occurrence.
Workers Compensation and Employers Liability Insurance	Employers' Liability with limits of at least \$500,000 each accident, \$500,000 by disease policy limit, \$500,000 by disease each employee.
Railroad Protective Liability Insurance	Coverage of at least \$2,000,000 per occurrence and \$6,000,000 in the aggregate, with the exception of New Mexico in which coverage is \$5,000,000 per occurrence and \$10,000,000 in the aggregate
Note: These limits are subject to change without notice. An Agreement will be provided to you, which contains details concerning insurance requirements.	

Please send the following so we may process your License request:

1. If License is for a Seismic Survey send a copy of your **Lease Agreement**.
2. **Completed Application**.
3. **\$800 non-refundable application fee**. This is not in lieu of a permit agreement fee. Check should be made payable to BNSF Railway Company.
4. **One set of drawings** (no larger than 11 x 17) for the area to be occupied. (Include: streets, distance from tracks and streets, mileposts if available and any distinguishing land marks.) Please ensure all information is accurate, as each change will add an additional \$800 to the application fee.

Forward application and payments to:
 Jones Lang LaSalle Brokerage, Inc.
 Attn: Permit Services
 4200 Buckingham, Ste.110
 Ft. Worth, TX 76155



APPLICATION FOR TEMPORARY OCCUPANCY

Jones Lang LaSalle Brokerage, Inc.

Attn: Permit Services

4200 Buckingham

Suite 110

Fort Worth, TX 76155

We submit for your approval the following application for temporary occupancy on BNSF Railway Company's right of way as shown on the enclosed location plan and detailed sketch.

Legal Name of Company/Municipality that will occupy the property _____

If a corporation State in which incorporated TX (If not incorporated, attach name(s) of owners or partners.)

Contact Name: _____ Phone # _____ FAX _____

Mailing Address: _____

Email Address: _____

Is this project **ARRA** funded? Yes No

Is this a condemning authority? Yes No

Is Applicant a Railroad Shipper? Yes No

If yes, BNSF Marketing Rep Name _____ Phone # _____

Was this service requested by BNSF? Yes No

If yes, BNSF person requesting service _____ Phone # _____

Is this in conjunction with a track or track expansion project? Yes No

If yes, BNSF contact name _____ Phone # _____

Purpose of Occupancy? _____

Name of nearest town on RR _____ County _____ State _____

Name of nearest roadway crossing RR _____

Location of proposed occupancy _____ 1/4 Section _____ Township _____ Range _____

Railroad Milepost _____ Latitude _____ Longitude _____

Is the work to be performed within 50 ft. of the track? Yes No

Percentage of project done within 50 ft. of the tracks. _____ %

Area to be occupied _____ ft. (x) _____ ft.

Length of time for Project: Date from: _____ Date to: _____

Will a crossing under the railroad tracks be required? Yes No

If yes, location of railroad mileposts _____

Total cost of project \$ _____

For a Seismic Survey:

Dates you will actually be on property Total # of cables on property

Attached to this sheet is a location plan and a detailed sketch. Shown on the sketch are exact dimensions of the project area and distances to the centerline of nearest railroad track and road crossing, bridge or other railroad structure.

I understand that submission of this application *does not* authorize occupancy of the property. Exact fees and insurance requirements will be forwarded after the application has been reviewed and approved by the BNSF.

Date: _____

Signed: _____

Print Name: _____

Title: _____

Phone #: _____ FAX _____

If you require additional assistance, please contact your [Jones Lang LaSalle Brokerage, Inc.](http://www.jll.com) representative.



Frequently Asked Questions on Flagging Charges

- **Why does my project require a flagman?**

Per Federal Law, BNSF must provide a flagman for any work being performed within twenty-five feet of the main tracks.

BNSF may find it necessary to provide a flagman if a project is outside of twenty-five feet in instances where there is danger of the track getting fouled. For example, a large crane with a base standing outside of the twenty-five feet mark but with an arm that may extend within twenty-five feet of the track. BNSF and local supervision reserve the right to add additional distance up to the ROW line if necessary if local conditions exist that may interfere with safety for all.

Flagmen are essential to protecting the safety and well being of the outside workforce. Injuries and fatalities of the outside workforce have dropped substantially since the inception of the "flagman rule". Please keep in mind that all flagmen are thoroughly trained on the proper safety precautions that are vital when working on the rail.

- **Why am I being charged for more than eight hours on a day when my crew was only there eight hours?**

The flagman has to do many things "behind the scenes" in order to prepare for a project. This may be one reason why your charges are more than eight hours even if the duration of the project was only eight hours (in a single day).

A flagman's hours start once he reaches the local yard. The flagman's hours begin here because he must start to prepare for your project. He must collect any needed safety materials and in addition, he must ensure that all other railroad employees that may need to come into the area are well informed of the project that will be taking place while informing himself of any possible complications that this project may create.

Further, the commute time from the local yard to the actual project will also play a factor in the variance between the contractor's project hours and the flagman's project hours.

Once the flagman reaches the site, he must set up warning devices several miles away from the site (in both directions of the traffic) in order to ensure that all locomotive engineers are properly warned to be on high alert therefore ensuring maximum safety.

Lastly, after the contractor's day is over, the flagman must then collect all posted warning notices. Then must travel back to the local yard and input the day's activity into the computer. After all this is done, the time stops.

- **Why am I being charged for a full eight-hour day when we were not out a full eight hours?**

Due to Railroad Union Labor Rules, BNSF must compensate an employee for a full eight-hour workday at minimum. This means that if your project only lasts a few hours on a given day, BNSF must still pay the flagger for a full day's work.



Frequently Asked Questions on Flagging Charges

- **Why am I being charged so much per hour for a flagman?**

When BNSF provides a flagman for a particular project, it is essentially losing a part of its labor force in order to work your project. The hourly rate that is seen on the bill includes other payroll-associated costs other than just the standard hourly pay earned by the employee. The railroad must also compute the cost of payroll and equipment additives that still must be paid to the employee while another company uses their services.

- **The flagman that was assigned to my project seemed to leave at different points throughout the day. Where was he going?**

In addition to breaks and lunches, flagman must sometimes leave the job site in order to meet an oncoming train that has announced that it is arriving in the vicinity of the project. An example would be a place where there is a manual switch that has to be thrown and requires the flagman to divert the direction of the train.

- **Why am I being charged over-time or double-time on my project?**

BNSF must pay employees over-time in instances where the project lasts over the regular eight hour workday. Further, if it is necessary for the project to extend to Saturday, labor rules require over-time (time and a half) be paid to the flagman. If the project must be worked on Sunday or on a holiday, it will be necessary to pay the flagman double-time.

- **I was a subcontractor hired through another party for this project. Why am I being charged for flagging instead of the other party?**

BNSF must seek reimbursement from the party that was physically provided the flagging protection. If your company had an agreement with a third party contractor, then it is your responsibility to seek reimbursement from that third party. Legal responsibility shall be assigned to the party that was physically there.

- **Why are there charges for more than one person on a given day?**

In instances where work is being performed in or around double or triple track, it is necessary for the railroad to provide more than one person to ensure that all streams of traffic are protected.

Further, when work is done affecting the structure of the track itself a track inspector will be needed. A certified track inspector will need to go out and inspect the track to ensure that it is structurally safe and is the track is within the proper operating guidelines.

- **Why was I charged for a day that my team did not work?**

When a contractor elects not to work on their project on a given day, BNSF must be informed so that a flagman is not sent out to the job site. If BNSF is not informed and a flagman is sent to the site, BNSF must pay the flagman for the entire eight-hour workday and thus bill the contractor for this expense.



Frequently Asked Questions on Flagging Charges

- **What happens if I don't pay this flagging bill?**

BNSF is legally entitled to seek full compensation for the full amount that was expensed on this project. If a flagging bill goes unpaid, BNSF will make several attempts to contact your company. After several attempts have been made, BNSF has the right to pursue legal action against the contractor to try and retrieve the amount that is owed (including court costs and legal fees).

Depending on geographical location of the project, BNSF may also report the non-payment to the local municipality. The local municipality may then put the contractor on a list of contractors with delinquent debt outstanding and may hinder their chances of receiving bids on local projects. When the project is being done in conjunction or for the State, BNSF has the right to place a lien on the project thus hampering the contractor from receiving all the funds that they were entitled to.

BNSF may also refuse to work with this contractor in the future and refuse access to any parts of the railroads property until all payments are made in full and all costs have been reimbursed. Further, BNSF may elect to withhold any existing payments that are reciprocally due to the company in question until an agreement has been reached between the two parties.

Further, your account may be placed with an outside Collections Agency and reported to the proper Credit Reporting agencies.

- **What is the billing rate?**

*BNSF Railway will charge for one person flagging per day:

Approximately - \$750.00 for 8 Hours of straight-time Monday - Friday ONLY & \$225.00 for every hour of overtime worked. (**Overhead rate 218.78 % over and above)

This includes any travel time to and from the Job site, setting up and taking down Form B, obtaining dispatching orders, unscheduled lunch period and filling out paper work at the end of shift

If the customer works an 8 hour day BNSF will bill you for 8 straight hours and 2 overtime hours for one person.

**This is only an estimate – Customer is responsible for the actual daily rate of the employee flagging for the day.*

***Periodically updates*

SECTION IX: LIST OF DRAWINGS- EXHIBIT C (NOT USED)

SECTION X: LEVEL 3 SAFETY SPECIFICATIONS - EXHIBIT I

LEVEL 3 HEALTH, SAFETY AND ENVIRONMENTAL (HSE) SPECIFICATIONS

REQUIRED HSE SUBMITTAL SUMMARY

The contractor shall submit copies of the items listed below for contract scope work on OCTA projects and property. Copies shall be provided prior to contractor's mobilization onto OCTA projects and property. Contractor shall provide compliant written Health, Safety & Environmental (HSE) submittals within 30 days of the contract notice to proceed.

HSE submittals shall comply with the 1988 Drug Free Workplace Act, or the Department of Transportation (DOT), or the Federal Transportation Administration (FTA) requirements (according to OCTA procurement funding guidelines) and comply with the California Code of Regulations (CCR) Title 8 regulatory standards.

Contractor's established written programs/plans shall comply with CCR Title 8 regulatory standards. All HSE related programs/plans submitted to OCTA for acceptance shall be prepared and submitted by a qualified HSE professional who is recognized by an organization of industry standard (i.e., CSP, CIH, CHST, CHMM, etc.) and is experienced in developing compliant written HSE programs. The site safety HSE representative shall participate in the HSE submittal process.

1. Contractor shall provide a copy of Company's Injury Illness Prevention Program in accordance with CCR Title 8, Section 3203.
2. Contractor shall provide a copy of their Company HSE Policy/Procedure Manual, in compliance with CCR Title 8 Standards for awarded scope.
3. Contractor shall provide a copy of their Policy or Substance Abuse Prevention Program.
4. Contractor shall provide a copy of their Hazard Communication Program and MSDS Management Program in compliance with CCR Title 8, Section 5194, Hazard Communication Standard.
5. On-Site HSE Representative:
On Facility Modification Projects, The Contractor shall submit a resume of the designated on-site qualified HSE Representative. The HSE Representative shall possess a current certification from the Board of Certified Safety Professionals (BCSP), plus five (5) years construction or scope agreement HSE experience enforcing HSE compliance on heavy or industrial construction project sites, the last two years of which have been administering HSE in the construction or scope discipline for which the Contractor is contracting with the Authority. The designated HSE Representative shall participate in all HSE related submittals through completion of scope.

On Capital Programs, The Contractor's on-site qualified HSE Representative shall be a Certified Safety Professional (CSP) with current standing from the Board of Certified Safety Professionals (BCSP) or a Construction Health and Safety Technician (CHST) with current standing from the (BCSP) or a Certified Industrial Hygienist (CIH) with current standing from the American Board of Industrial Hygiene (ABIH), or an equal professional HSE Certificate of standing from The National Examination Board in

Occupational Safety and Health (NEBOSH), that is acceptable to the Authority. The Contractor's on-site HSE Representative(s) shall provide a resume and have a minimum of seven (7) years heavy construction experience in administering HSE programs on heavy construction project sites, the last two years of which have been administering HSE in the construction/scope discipline for which Contractor is contracting with the Authority.

6. A Detailed Site Specific HSE Work Implementation Plan:

This plan shall be prepared and submitted by a recognized HSE professional experienced in developing compliant written HSE programs. Indicate the methods and procedures, and include the sequence of tasks as listed on the project schedule, include the hazards, tools and equipment, and the safe work practices to mitigate the hazards in a format acceptable OCTA. Specify safety measures in accordance with applicable Cal/OSHA standards, South Coast Air Quality Management District (SCAQMD) rules, National Fire Protection Association (NFPA), National Electric Code (NEC), American National Standards Institute (ANSI) codes and regulations, job hazard analysis, policies, procedures, HSE training requirements and known and potential hazards of Contractor's scope. Plans shall be prepared as specified above, and may require if necessary a professional engineer licensed to practice in the state of California, when so required by the provisions of the California Board for Professional Engineer and Surveyors.

PART I – GENERAL

1.0 GENERAL HEALTH, SAFETY AND ENVIRONMENTAL REQUIREMENTS

- A. The Contractor, its subcontractors, suppliers, and employees have the obligation to comply with all Authority health, safety and environmental compliance department (HSEC) requirements of this safety specification, project site requirements, and bus yard safety rules, as well as all federal, state, and local regulations pertaining to scope of work or agreements with the Authority including California Department of Transportation safety requirements and special provisions. Additionally, manufacturer requirements are considered incorporated by reference, as applicable, to this scope of work.
- B. Observance of unsafe acts or conditions, serious violation of health and safety standards, non-conformance of Authority HSEC requirements, or disregard for the intent of these safety specifications to protect people and property, by Contractor may be reason for termination of scope or agreements with the Authority, at the sole discretion of the Authority.
- C. The Authority HSEC requirements, and references contained within this scope of work shall not be considered all-inclusive as to the hazards that might be encountered. Safe work practices shall be pre-planned and performed, and safe conditions shall be maintained during the course of this work scope.
- D. The Contractor shall specifically acknowledge that it has primary responsibility to prevent and correct all health, safety and environmental hazards for which it and its employees, or its subcontractors (and their employees) are responsible. The Contractor shall further acknowledge their expertise in recognition and prevention of hazards in the operations for which they are responsible, that the Authority may

not have such expertise, and is relying upon the Contractor for such expertise. The Authority retains the right to notify the Contractor of potential hazards and request the Contractor to evaluate and, as necessary, to eliminate those hazards.

- E. The Contractor shall provide all necessary tools, equipment, and related safety protective devices to execute the scope of work in compliance with the Authority's HSEC requirements, CCR Title 8 Standards, and recognized safe work practices.
- F. The Contractor shall instruct all its employees, and all associated sub-contractors under contract with the Contractor who works on Authority projects in the following; recognition, identification, and avoidance of unsafe acts and/or conditions applicable to its work.

PART II – SPECIFIC REQUIREMENTS

2.0 While these safety specifications are intended to promote safe work practices, Contractors are reminded of their obligation to comply with all federal (Code of Federal Regulations (CFR) Sections 1926 & 1910 Standards), state (CCR Title 8 Standards), local and municipal safety regulations, and Authority health, safety and environmental requirements applicable to their project scope. Failure to comply with these standards may be cause for termination of scope or agreements with the Authority, at the sole discretion of the Authority.

2.1 REQUIRED DOCUMENTATION / REPORTING REQUIREMENTS

The Contractor at a minimum shall provide the following documents to the Authority's Project Manager. Items A through E below shall be submitted and accepted by the Authority's Project Manager prior to Contractor mobilization. Item F upon each occurrence, and for items G through K, contractor shall verify the following documentation is in place, prior to and during contract scope and make the same available to the Authority upon request within 72 hours.

Contractor's established written programs/plans shall comply with CCR Title 8 regulatory standards. All new programs/plans shall be prepared and submitted by a qualified HSE professional who is recognized by an organization of industry standard (i.e., CSP, CIH, CHST, STS, CHMM, etc.) and is experienced in developing compliant written HSE programs. The site safety HSE representative shall participate in the scope submittal process.

- A. A Comprehensive Project Specific Health, Safety, and Environmental (HSE) Work Plan.
 - a. The Contractor shall develop a site project plan that may include, but is not limited to: Permits, Evacuation, Emergency Plan, Roles and Responsibilities, Scope and Construction Activity Details, Constructability Review, Contractor Coordination Process, Safe Work Methods, Hazard Identification & Risk Control, First Aid and Injury Management, Emergency Procedures, Public Protection, Authority and Contractor Site Rules, Incident Reporting and Investigation, Specialized Work or Licensing, Training and Orientation Requirements, Chemical Management, and Subcontractor Management.

- b. A Detailed Site Specific HSE Implementation Plan: This plan shall be prepared and submitted by a recognized HSE professional (current BCSP Certification in good standing, i.e., CSP, CHST, OHST) experienced in developing compliant written HSE programs, acceptable to OCTA. Indicate the methods and procedures, and include the sequence of tasks as listed on the project schedule, include the hazards, tools and equipment, and the safe work practices to mitigate the hazards in a format acceptable OCTA. Specify safety measures in accordance with applicable Cal/OSHA standards, SCAQMD rules, NFPA, NEC, ANSI codes and regulations, job hazard analysis, policies, procedures, HSE training requirements and known and potential hazards of Contractor's scope. Plans shall be prepared as specified above, and may require if necessary a professional engineer licensed to practice in the state of California, when so required by the provisions of the California Board for Professional Engineer and Surveyors.
- B. Contractor shall provide a copy of their Company HSE Policy/Procedure Manual, in compliance with CCR Title 8 Standards for awarded scope.
- C. Contractor shall provide a copy of Company's Injury Illness Prevention Program in accordance with CCR Title 8, Section 3203.
- D. Contractor shall provide a copy of their Policy or Substance Abuse Prevention Program that complies with the 1988 Drug Free Workplace Act.
- E. Contractor shall provide the resume and qualifications/certifications of assigned project designated Onsite HSE Representative for this scope as identified in section 2.3 of this specification.
- F. Accident/Incident investigation report within 24 hours of event (immediate verbal notification to Authority Project Manager, followed by Written Report).

The following required documentation shall be provided to the Authority's Project Manager, upon Authority request, within 72 hours.

- G. A copy of Contractor weekly site safety inspection report with status of corrections, upon request, within 72 hours.
- H. Contractor shall provide a copy of the Contractors and subcontractors competent person list (submit to Authority Project Manager, upon Authority request, within 72 hours).
- I. Contractors and subcontractors training records for qualified equipment operators, electrical worker certification (NFPA 70E), confined space training, HAZWOPER training, and similar personnel safety training certificates as applicable to the agreement scope and as requested by the OCTA Project Manager and/or HSEC department, upon Authority request, within 72 hours and prior to starting or during the scope activity (submit to Project Manager).

J. A monthly report that includes number of workers on project, a list of subcontractors, work hours (month, year to date, & project cumulative) of each contractor, labor designation, OSHA Recordable injuries and illnesses segregated by medical treatment cases, restricted workday cases, number of restricted days, lost workday cases, and number of lost work days, and recordable incident rate. Contractor shall provide to the Authority, upon request, within 72 hours.

K. TRAINING DOCUMENTATION

To ensure that each employee is qualified to perform their assigned work, when applicable to scope work, Contractor shall verify training documentation is in place, prior to and during contract scope, and make available to the Authority, upon request, within 72 hours. Training may be required by the Authority or CCR Title 8 Standards and required for activity on Authority's property and/or Authority projects. Contractor shall provide to Authority, upon request, within 72 hours.

2.2 HAZARD COMMUNICATION (CCR Title 8, Section 5194)

- A. Contractor shall comply with CCR Title 8, Section 5194 Hazard Communication Standard. Prior to chemical use on Authority property and/or project work areas the Contractor shall provide to the Authority Project Manager copies of Material Safety Data Sheet (MSDS) for all applicable products used, if any.
- B. All chemicals including paint, solvents, detergents and similar substances shall comply with SCAQMD Rules 103, 1113, and 1171.

2.3 DESIGNATED HEALTH, SAFETY, ENVIRONMENTAL (HSE) REPRESENTATIVE

- A. Before beginning on-site activities, the Contractor shall designate an On-site HSE Representative. This person shall be a Competent or Qualified Individual as defined by the Occupational, Safety, and Health Administration (OSHA), familiar with applicable CCR Title 8 Standards, and has the authority to affect changes in work procedures that may have associated cost, schedule and budget impacts.
- B. The Contractor's on-site qualified HSE Representative for all Authority projects is subject to acceptance by the Authority Project Manager and the HSEC Department Manager. All contact information of the On-site HSE Representative (name, phone, and fax and pager/cell phone number) shall be provided to the Authority Project Manager.

QUALIFICATIONS – On Capital Programs, the Contractor shall submit a resume of the full time, on-site qualified HSE Representative(s) who reports directly to the Contractor's Project Manager or Superintendent, and who is responsible for HSE oversight for field operations on the project no later than ten (10) days after receipt of Notice to Proceed, and prior to mobilization. The Contractor's On-site HSE Representative(s) shall have a minimum of seven (7) years heavy construction experience in administering HSE programs on heavy construction project sites, the last two years of which have been administering HSE in the construction discipline for which Contractor is contracting with the Authority. The Contractor's

On-site HSE Representative shall be a Certified Safety Professional (CSP) with current standing from the Board of Certified Safety Professionals (BCSP), or a Construction Health and Safety Technician (CHST) with current standing from the BCSP or a Certified Industrial Hygienist (CIH) with current standing from the American Board of Industrial Hygiene (ABIH), or an equal professional HSE Certificate of standing from The National Examination Board in Occupational Safety and Health (NEBOSH), that is acceptable to the Authority. The Contractor's On-site HSE Representative(s) shall be on site during all operational hours. The On-site HSE Representative(s) shall set up, carry forward and aggressively and effectively maintain the project specific safety program and IIPP covering all phases of the work. If at any time the Contractor wishes to replace their On-site HSE Representative(s), the Contractor must provide written notice thirty (30) days prior to change of personnel to the Authority. The Contractor shall take all precautions and follow all procedures for the safety of, and shall provide all protection to prevent injury to, all persons involved in any way in the scope work and all other persons, including, without limitation, the employees, agents, guests, visitors, invitees and licensees of the Authority who may be involved. This requirement applies continuously and is not limited to normal working hours. The designated HSE Representative shall participate in all HSE related submittals. The Authority reserves the right to allow for an exception to modify these minimum qualification requirements for unforeseen circumstances, at the sole discretion of the Authority Project Manager and HSEC Department Manager.

On Facility Modification Projects, the Contractor shall submit a resume of the full time qualified on-site HSE Representative who reports directly to the Contractor's Project Manager or Superintendent, and who is responsible for safety oversight for field operations on the project no later than ten (10) days after receipt of Notice to Proceed, and prior to mobilization. The Contractor's On-Site HSE Representative shall hold a current certification from the BCSP, plus five (5) years construction or scope HSE experience enforcing HSE compliance on heavy construction or industrial construction project sites, the last two years of which have been administering HSE in the construction or scope discipline for which Contractor is contracting with the Authority. The Contractor's On-site HSE Representative(s) shall be on site during all operational hours. The designated HSE Representative shall participate in all HSE related submittals. The Authority reserves the right to allow for an exception and to modify these minimum qualification requirements for unforeseen circumstances, at the sole discretion of the Authority Project Manager and HSEC Department Manager.

1. Capital Programs may include, but are not limited to, projects involving demolition and construction of; heavy construction, rail projects, highway projects, parking lots and structures, fuel stations, building construction, facility modifications, bus base construction, EPA/DTSC remediation, AQMD air or soil monitoring, fuel tank removal or modification, major bus base modifications, handling potential hazardous waste projects, and similar projects as deemed a Capital Program at the sole discretion by the Authority.
2. Facility Modification Projects may include, but are not limited to, projects involving minor demolition and construction or improvement projects for transportation centers, bus base sites and/or building modifications, equipment

and/or building upgrades, and similar projects as deemed a Facility Modification Project at the sole discretion by the Authority.

3. Competent Individual means an individual who is capable of identifying existing and predictable hazards in the surroundings or working conditions which are unsanitary, hazardous, or dangerous to employees and/or property, and who has authorization to take prompt corrective measures to eliminate them.
 4. Qualified Individual means an individual who by possession of a recognized degree, certificate, certification or professional standing, or who by extensive knowledge, training, and experience, has successfully demonstrated his/her ability to solve or resolve problems relating to the subject matter, the work, or the project.
- C. The Contractor shall designate a Competent Individual for each task, as required by Cal-OSHA standards or laws. The task Competent Individual shall be responsible for the prevention of accidents. If the Authority or any public agency with jurisdiction notifies the Contractor of any claimed dangerous condition at the site that is within the Contractor's care, custody or control, the Contractor shall take immediate action to rectify the condition at no additional cost to the Authority. The Contractor shall be responsible for the payment of all fines levied against the Authority for deficiencies relating to the Contractor's supervision or conduct and/or control of the scope agreement.
- D. On Facility Modification Projects, the Authority Project Manager reserves the right to require the Contractor to provide one additional full-time safety representative with qualifications as identified in section 2.3 (C), above whenever the number of individuals from the Contractor, its subcontractors, suppliers, and vendors meets or exceeds 15 workers, there are multiple scope work sites, or as warranted by the scope of work at the sole discretion by the Authority.
- E. On Capital Programs, the Authority's Project Manager reserves the right to require the Contractor to provide one additional full-time safety representative with qualifications as identified in item 2.3 (C) above whenever the number of individuals from the Contractor, its subcontractors, suppliers, and vendors meets or exceeds 50 workers, or is warranted by the scope of work.

2.4 SITE HSE ORIENTATION

The Contractor shall conduct and document a project site safety orientation for all Contractor personnel, subcontractors, suppliers, vendors, and new employees assigned to the project prior to performing any work on Authority projects, a copy of the HSE orientation attendance list shall be provided to the Authority Project Manager. The safety orientation, at a minimum, shall include, as applicable, Personal Protection Equipment (PPE) requirements, eye protection, ANSI class 2 reflective vests, designated smoking, eating, and parking areas, traffic speed limit and routing, cell phone policy, and barricade requirements. When required by scope, additional orientation shall include fall protection, energy isolation lock-out/tag-out (LOTO), confined space, hot work permit, security requirements, and similar project safety requirements.

2.5 INCIDENT NOTIFICATION AND INVESTIGATION

- A. The Authority shall be promptly notified of any of the following types of incidents:
1. Damage to Authority property (or incidents involving third party property damage);
 2. Reportable and/or recordable injuries (as defined by the U. S. Occupational Safety and Health Administration);
 3. Incidents impacting the environment, i.e. spills or releases on Authority property.
- B. Notifications shall be made to Authority representatives, employees and/or agents. This includes incidents occurring to contractors, vendors, visitors, or members of the general public that arise from the performance of Authority contract work. An initial immediate verbal notification, followed by a written incident investigation report shall be submitted to Authority's Project Manager within 24 hours of the incident.

A final written incident investigative report shall be submitted within seven (7) calendar days, and include the following information. The current status of anyone injured, photos of the incident area, detailed description of what happened, the contributing factors that led to the incident occurrence, a copy of the company policy or procedure associated with the incident and evaluation of effectiveness, copy of the task planning documentation, copy of the Physician's first report of injury, updated OSHA 300 Log, and the corrective action initiated to prevent recurrence. This information shall be considered the minimum elements required for a comprehensive incident report acceptable to OCTA.

- C. A Serious Injury, Serious Incident, OSHA Recordable Injury / Illness, or Significant Near Miss shall require a formal incident review at the discretion of the Authority's Project Manager. The incident review shall be conducted within seven (7) calendar days of the incident. This review shall require a senior executive from the Contractors' organization to participate in the presentation. The serious incident presentation shall include action taken for the welfare of the injured, a status report of the injured, causation factors leading to the incident, a root cause analysis, and a detailed recovery plan that identifies corrective actions to prevent a similar incident, and actions to enhance safety awareness.
1. Serious Injury : includes an injury or illness to one or more employees, occurring in a place of employment or in connection with any employment, which requires inpatient hospitalization for a period in excess of twenty-four hours for other than medical observation, or in which an employee suffers the loss of any member of the body, or suffers any serious degree of physical disfigurement.

2. Serious Incident: includes property damage of \$500.00 or more, an incident requiring emergency services (local fire, paramedics and ambulance response), news media or OCTA media relations response, and/or incidents involving other agencies (Cal/OSHA, EPA, AQMD, DTSC, etc.) notification or representation.
3. OSHA Recordable Injury / Illness: includes and injury / illness resulting in medical treatment beyond First Aid, an injury / illness which requires restricted duty, or an injury / illness resulting in days away from work.
4. Significant Near Miss Incident: includes incidents where no property was damaged and no personal injury sustained, but where, given a slight shift in time or position, damage and/or injury easily could have occurred.

2.6 REGULAR INSPECTIONS & THIRD PARTY INSPECTIONS

- A. Frequent and regular inspections of the project jobsite shall be made by the Contractor's On-site HSE Representative, or another Competent Individual designated by the Contractor. Unsafe acts and/or conditions noted during inspections shall be corrected immediately.
- B. The Contractor is advised that representatives of regulatory agencies (i.e., CAL-OSHA, EPA, SCAQMD, etc.), upon proper identification, are entitled to access onto Authority property and projects. The Authority Project Manager shall be notified of their arrival as soon as possible.

2.7 ENVIRONMENTAL REQUIREMENTS

- A. The Contractor shall comply with Federal, State, county, municipal, and other local laws and regulations pertaining to the environment, including noise, aesthetics, air quality, water quality, contaminated soils, hazardous waste, storm water, and resources of archaeological significance. Expense of compliance with these laws and regulations is considered included in the agreement. Contractor shall provide water used for dust control, or for pre-wetting areas to be paved, as required; no payment will be made by OCTA for this water.
- B. The Contractor shall prevent pollution of storm drains, rivers, streams, irrigation ditches, and reservoirs with sediment or other harmful materials. Fuels, oils, bitumen, calcium chloride, cement, or other contaminants that would contribute to water pollution shall not be dumped into or placed where they will leach into storm drains, rivers, streams, irrigation ditches, or reservoirs. If operating equipment in streambeds or in and around open waters, protect the quality of ground water, wetlands, and surface waters.
- C. The Contractor shall protect adjacent properties and water resources from erosion and sediment damage throughout the duration of the contract. Contractor shall comply with applicable NPDES permits and Storm Water Pollution Prevention Plan (SWPPP) requirements.
- D. Contractor shall comply with all applicable EPA, Cal EPA, Cal Recycle, DTSC, SCAQMD, local, state, county and city standards, rules and regulations for

hazardous and special waste handling, recycling and/ disposal. At a minimum, Contractor shall ensure compliance where applicable with SCAQMD Rule 1166, CCR Title 8, Section 5192, 29 CFR Subpart 1910.120, 49 CFR Part 172, Subpart H, 40 CFR Subpart 265.16 and CCR Title 22 Section 6625.16. Contractor shall provide OCTA a schedule of all hazardous waste and special or industrial waste disposal dates in advance of transport date. Only authorized OCTA personnel shall sign manifests for OCTA generated wastes. Contractor shall ensure that only current registered transporters are used for disposal of hazardous waste and industrial wastes. The Contractor shall obtain approval from OCTA for the disposal site locations in advance of scheduled transport date.

- E. If the Contractor encounters on the site material reasonably believed to be asbestos, polychlorinated biphenyl (PCB) or other Hazardous Substance (as defined in California Health and Safety Code, and all regulations pursuant thereto) which has not been rendered harmless, the Contractor shall immediately stop work in that area affected and report the condition to the Authority in writing. The work in the affected area shall not thereafter be resumed except by written agreement of the Authority and Contractor if in fact the material is asbestos or polychlorinated biphenyl (PCB) or other hazardous substance and has not been rendered harmless. The work in the affected area shall be resumed in the absence of asbestos or polychlorinated biphenyl (PCB) or other hazardous substance, or when it has been rendered harmless, by written agreement of the Authority and the Contractor, or in accordance with a final determination by an Environmental Consultant employed by the Authority.
- F. The Contractor shall not permit any hazardous substances to be brought onto or stored at the Project Site or used in the construction of the work, except for specified materials and commonly used construction materials for which there are no reasonable substitutes. All such materials shall be handled in accordance with all manufacturers' guidelines, warnings and recommendations and in full compliance with all applicable laws. All notices required to be given with respect to such materials shall be given by the Contractor. The Contractor shall not intentionally release or dispose of hazardous substances at the Project Site or into the soil, drains, surface or ground water, or air, nor shall the Contractor allow any Sub-Contractor, subcontractor or supplier or any other person for whose acts the Contractor or any subcontractor, vendor or supplier may be liable, to do so. For purposes of Contract Documents, "hazardous substance" means any substance or material which has been determined or during the time of performance of the work is determined to be capable of posing a risk of injury to health, safety, property or the environment by any federal, state or local governmental authority.

2.8 VEHICLE AND ROADWAY SAFETY REQUIREMENTS

- A. The Contractor shall ensure that all Contractor vehicles, including those of its subcontractors, suppliers, vendors and employees are parked in designated parking areas, are identified by company name and/or logo, and comply with traffic routes, and posted traffic signs in areas other than the employee parking lots.

- B. Personal vehicles belonging to Contractor employees shall not be parked on the traveled way or shoulders including any section closed to public traffic, or areas of the community that may cause interference or complaints
- C. The Contractor shall comply with California Department of Transportation safety requirements and special provisions when working on highway projects.
- D. The Contractor shall conform to American Traffic Safety Services Association (Quality Standard for Work Zone Control Devices 1992).

2.9 LANGUAGE REQUIREMENTS

For safety reasons, the Contractor shall ensure employees that do not read, or understand English, shall be within visual and hearing range of a bilingual supervisor or responsible designee at all times when on the Authority property or projects.

2.10 PERSONAL PROTECTIVE EQUIPMENT AND CLOTHING

Contractors, and all associated subcontractors, vendors and suppliers are required to provide their own personal protective equipment (PPE), including eye, head, foot, and hand protection, respirators, reflective safety vests, and all other PPE required to perform their work safely on Authority projects.

- A. RESPIRATORS (CCR Title 8, Section 5144) - The required documentation for training and respirator use shall be provided to the Authority's Project Manager upon request within 72 hours. All compliance documentation as required by CCR Title 8, Section 5144, Respiratory Protective Equipment.
- B. EYE PROTECTION – The Authority requires eye protection on construction projects and work areas that meet ANSI Z-87.1 Standards.
- C. BUS BASE – Minimum PPE required includes but is not limited to; Eye protection, class 2 reflective vest, steel toe or construction type footwear that meets ANSI Z41 1991 are recommended.
- D. CONSTRUCTION PROJECTS - Minimum PPE required includes but is not limited to; hard hat, eye protection, hand protection, class 2 reflective vest, safety toe footwear that meets ANSI Z41 1991 are recommended.
- E. HARD HATS: Approved hard hat that meet ANSI Z89. 1 (latest revision). Hard hats should be affixed with the company/agency logo and/or name. The bill shall be worn forward. Metal hard hats and cowboy style are forbidden on Authority projects.
- F. FOOTWEAR: Enclosed leather that covers the ankles, such as a construction type boot. Employees shall not wear casual dress shoes, open toe, sneakers, sandals, canvas-type shoes, or other shoes that have thin soles or heels that are higher than normal in construction work areas. Safety toe footwear that meets ANSI Z41 1991 are recommended on construction sites and in operating facilities.

- G. CLOTHING/SHIRTS: minimum or waist length shirts with sleeves (4" minimum).
- H. CLOTHING/TROUSERS: Cover the entire leg. If flare-legged trousers are worn, the trouser bottoms must be tied to prevent catching. No sweat pants, or trousers with holes.

2.11 AERIAL DEVICES (CCR Title 8, Section 3648)

Aerial devices are defined in CCR Title 8 as any vehicle-mounted or self-propelled device, telescoping extensible or articulating, or both, which is primarily designed to position personnel. If aerial devices are to be used, the required documentation in CCR Title 8, Section 3648 shall be provided to the Authority's Project Manager, upon request, within 72 hours.

2.12 CONFINED SPACE ENTRY (CCR Title 8, Section 5157)

Before any employee will be allowed to enter a confined space, the required documentation as required by CCR Title 8, Section 5157 shall be provided to the Authority's Project Manager, upon request, within 72 hours.

- A. RECOMMENDED: a copy of the most recent calibration record for each air monitoring unit, 3-gas monitor or "sniffer" to be used by the Entry Supervisor prior to entering permit-required confined spaces.

2.13 CRANES

- A. Crane activity shall comply with 29 CFR 1926.550, CCR Title 8 Standards, manufacture's recommendations and requirements, applicable American Society of Mechanical Engineers (ASME), and ANSI Standards. In addition, Contractor shall comply with the following requirements: Prior to using mobile cranes, the Contractor shall provide to the Authority Project Manager, items 1, 2 & 3 of the following documentation a minimum of seven (7) days prior to activity, and item 4 on each day of crane activity.
 1. Cranes require a submittal of the annual certification, and copy of the cranes most recent quarterly inspection.
 2. A copy of each crane operator's qualification (NCCCO or equivalent) of company-authorized crane operators that have been properly trained in the equipment's use and limitations. Operator certification as required by CCR Title 8, Section 5006.1.
 3. A rigging plan is required for all lifts. Critical lifts require an engineered plan designed by a registered professional engineer licensed in the State of California.
 4. Contractor shall provide the name and qualifications of each "Qualified Rigger" as defined by OSHA.

5. Rigging scope activity shall comply with 29 CFR Subparts 1926.250, 1929.753 and CCR Title 8 Standards.
 6. All rigging equipment shall be free from defects, in good operating condition and maintained in a safe condition.
 7. Rigging equipment shall be inspected by a designated, competent employee prior to initial use on the project, prior to each use, and documented inspections performed regularly. Records shall be kept on jobsite of each of these inspections by contractor and be made available to the Authority upon request within 72 hours.
 8. Only one (1) sling eye should be in a hook, for multiple slings a shackle shall be used to prevent separation of slings, and prevent stress on weak points of the hook.
 9. Contractor shall prepare a documented daily crane inspection report.
- B. Pick and carry with rubber tired cranes is forbidden on Authority projects.
- C. Engineered Critical Lifts

A critical lift is established where any one of the following conditions are created:

1. Where in the crane's current configuration at any point during the lift, a gross load weight exceeds 75% of the capacity of the crane.
2. A gross weight equal to, or greater than 10 tons.
3. Lifts over buildings, equipment, public roadways, structures, or power lines.
4. A single lift where two or more cranes are used, including tandem lifts and tailing cranes.
5. Lifts made in close proximity of power lines, as defined by CCR Title 8 voltage clearance specifications.
6. Lifts involving helicopters, and specialized or unique and complex rigging equipment.
7. Hoisting of suspended work platforms.
8. Static tower crane erection and dismantlement.
9. Making lifts below the ground level where the crane is positioned.

Note: Where the below the ground lift is minimal (evaluated by California registered professional engineer), a critical lift plan may not be required.

D. Critical Lift Plan

Where a critical lift will be performed, a written critical lift plan shall be submitted to the Authority Project Manager prior to commencing with the lift. The written plan shall include the following:

1. Crane manufacturer, capacity, and all specifications for the configuration to be used for the lift.
2. Load chart data for the crane to be used to make the lift. Total calculated weight of the load to be lifted including all rigging and other deductions consistent with the manufacturer's load chart.
3. Engineering data shall be provided on the hook assembly (manufacturer's certification or independent laboratory testing and load testing within the past 60 days), below-the hook rigging, and all specialized below-the-hook lifting devices.
4. Diagrams of the lift that provides geometrical conditions of the load, rigging, and all crane positions during the lift. The drawing shall provide the following:
 - A. Locations of all components to be lifted prior, during and after the lift is completed.
 - B. Radius points.
 - C. Swing patterns.
 - D. In the event that the lift must be aborted, positions where the load may be safely landed.
 - E. Areas where any personnel, public, and vehicles must be evacuated during the lift.
5. Potential ground loading for each point of contact by the crane in selected locations in which the crane will perform the critical lift.
6. Soil and subsurface data and information pertaining to the location on which the crane used for the critical lift will be positioned. This information shall be procured from an authoritative source such as a geotechnical engineer or a professional civil engineer registered in the state of California.

Note: *This information may be available from the Authority for selected locations on some projects.*

7. An engineer shall use the data provided in #5 and #6 above to verify and confirm the following:
 - A. That the soil and subsurface conditions are capable of supporting all loads imposed during the critical lift.
 - B. That the designs of cribbing and other supports used under the crane load points are appropriate to safely transfer such loads.
8. Signature and stamp on the plan by a California registered professional engineer, evidencing review of the plan as meeting the requirements that all loads and load information and calculations contained in the plan are approved, acceptable and safe to perform.
9. Operator qualifications.
10. Method by which communication will be provided to the crane operator. (Designated signal person, two-way radio, hard wire phone system, etc.).
11. A critical lift hazard analysis which identifies the particular hazards (including weather, wind, obstructions, etc.) associated with the lift and the means and methods to reduce, mitigate, or eliminate the hazards.
12. Emergency action plan.
13. Documentation of lift and pre-job meeting shall be conducted by Contractor's Project Manager.

The written plan shall be submitted 7 days prior to any critical lift for review by the Authority Project Manager and the Authority HSEC department. No critical lifts shall be conducted prior to such review.

E. OVERHEAD CRANES

Before using the Authority overhead cranes, each Contractor shall designate a limited number of employees to attend a training session on the use and limitations of overhead cranes with designated Authority personnel.

2.14 DEMOLITION OPERATIONS (CCR Title 8, Section 1734)

Before starting demolition activities the required documentation shall be provided to the Authority's Project Manager, upon request, within 72 hours. Contractor shall provide all compliance documentation as required by CCR Title 8 Article 31.

- A. The Contractor shall be responsible for visiting and examining the project site to assess and personally determine the extent of demolition, associated work, debris removal, disposal and general work to be done under this section.
- B. The Contractor shall take possession of all demolished materials, except as noted otherwise in the Contract Documents, and be responsible for disposing of them in accordance with applicable laws and regulations. On-site burning or burial of demolition materials will not be permitted.
- C. Provide continuous noise and dust abatement as required, preventing disturbances and nuisances to the public, workers, and the occupants of adjacent premises and the surrounding areas. Dampen areas affected by demolition operation as necessary to prevent dust nuisance.
- D. Site demolition plan: Indicate methods, procedures, equipment, and structures to be employed. Specify safety measures in accordance with applicable codes including signs, barriers, and temporary walkways. Plans shall be prepared by a qualified person (CSP, CIH, CHST, CHMM, etc.), or as necessary by a professional engineer licensed to practice in the State of California, when so required by the provisions of the California Board for Professional Engineer and Surveyors.
- E. Equipment, haul routes, and disposal sites to be used in the demolition and disposal work. Copy of manifests showing delivery of disposed materials in accordance with the plan and permit conditions. Certification that all demolished materials removed from the site have been disposed of in accordance with applicable laws and regulations.

2.15 EXCAVATION OPERATIONS (CCR Title 8, Section 1541)

Before starting excavation activities more than 5 feet deep into which people shall enter, the required documentation shall be provided to the Authority's Project Manager, upon request, within 72 hours. All compliance documentation shall comply with the following CCR Title 8, Section 1541 requirements:

- A. A copy of the Contractor's Excavation Permit.
- B. Attention is directed to the applicable sections of the Labor Code concerning trench excavation safety plans, "Trench Safety." Excavation for any trench 5 feet or more in depth shall not begin until the Contractor has received approval from the Engineer of the Contractor's detailed plan for worker protection from the hazards of caving ground during the excavation of that trench and any design calculations used in the preparation of the detailed plan. Excavations 20 feet or greater shall be engineered and plan stamped by a California registered professional engineer.
- C. The detailed plan shall show the details of the design of shoring, bracing, sloping or other provisions to be made for worker protection during the excavation. No plan shall allow the use of shoring, sloping or a protective system less effective than that required by the Construction Safety Orders of the Division of Occupational Safety and Health. If the plan complies with the shoring system

standards established by the Construction Safety Orders, the plan shall be submitted at least five (5) days before the Contractor intends to begin excavation for the trench.

- D. Excavations and trenches shall be inspected by a “Competent Person” daily and after every rainfall to determine if they are safe. Daily inspections shall be recorded. Documentation is to be kept on site and available for review upon request.
- E. Excavations are considered class ‘C’ soil unless documented testing in accordance with 29 CFR Subpart P, Section 1926.650 and CCR Title 8 Standards supports a class ‘B’ soil classification and is confirmed and stamped by a California registered professional engineer. In no case will excavations be classified as class ‘A’ soil.

2.16 FALL PROTECTION (CCR Title 8, Sections 1669-1671)

The following standards are required when performing work on Authority property. The required documentation shall be provided to the Authority’s Project Manager, upon request, within 72 hours.

- A. Fall protection is required for workers exposed to falls in excess of six (6) feet.
- B. When conventional fall protections methods are impractical or create a greater hazard, a written plan in conformance with CCR Title 8, Article 24, shall be submitted to the Authority a minimum of seven (7) days in advance of the scheduled activity.

2.17 FORKLIFTS, BACKHOES AND OTHER INDUSTRIAL TRACTORS (CCR Title 8, Section 3664)

CCR Title 8 defines backhoes as “industrial tractors”. All compliance documentation shall be provided as required by CCR Title 8, Section 3664. The following required documentation shall be provided to the Authority’s Project Manager, upon request, within 72 hours:

- A. A copy of each operator’s certificate or a list of company-authorized industrial tractor operators that have been properly trained in the equipment’s use and limitations. Please state which equipment, and model each operator has been authorized to operate (i.e. forklifts, backhoe, bulldozer, front-end loader, etc.).

2.18 ELECTRICAL OPERATIONS

HIGH VOLTAGE (CCR Title 8, Sections 2700-2974)

Any work on electrical equipment defined by OSHA as high-voltage, at or above 600 volts, requires specialized training certifications and personal protective equipment. Before any high-voltage work commences, the Authority Project Manger must be notified and must provide approval. The following required NFPA 70E certification and a certificate of training from a recognized organization of a two day high voltage safety

training course shall be provided to the Authority's Project Manager, upon request, within 72 hours:

- A. A list of the name(s) of the company-designated high voltage Qualified Electrical Worker(s)
LOW VOLTAGE (CCR Title 8, Sections 2299-2599)

Only qualified persons shall work on electrical equipment or systems.

- A. Electrical Certification of Training; Contractor employees working on or around electrical panels, wiring, motors, electrical energy sources or similar electrical devices shall have attended a NFPA 70E, Electrical Safety Course and provide to the OCTA Project Manager a copy of employees' NFPA 70E qualification certificate of training for each employee assigned to electrical tasks on OCTA property or projects.

2.19 POWDER-ACTUATED TOOLS (CCR Title 8, Section 1685)

Before using tools such as "Hilti guns" or other powder-actuated tools, the following required documentation shall be provided to the Authority's Project Manager, upon request, within 72 hours.

- A. A copy of each qualified person's valid operator card.

2.20 SCAFFOLDS (CCR Title 8, Sections 1635.1-1677)

Scaffold erection shall be in compliance with CCR Title 8 Standards. All compliance documentation shall be provided as required by CCR Title 8, Sections 1635.1-1677. In addition, the Contractor shall comply with the following additional requirements.

- A. All scaffolds on Authority project shall be inspected by a competent person qualified for scaffolds in accordance with CCR Title 8 Standards.
- B. Contractor shall arrange for a third party inspection, at least quarterly, by a credentialed professional (insurance carrier, scaffold manufacturer representative, or similar) in addition to the contractors daily self inspections.
- C. A proper scaffold inspection and tagging system shall be maintained identifying compliance status (Example: Green/safe, Yellow/modified-fall protection required, Red/unsafe-do not use).
- D. Contractor shall have a fall protection plan that meets CCR Title 8 Standards for scaffold erectors, an erection/dismantling plan shall be submitted to Authority Project Manager for review prior to start of activity.
- E. Scaffold erection/dismantling shall install handrails beginning on the first level above ground erected, and erectors shall plan erection and dismantling in a manner to maximize handrail protection and minimize employees at unprotected areas.

2.21 WARNING SIGNS AND DEVICES

Signs, signals, and/or barricades shall be visible at all times when and where a hazard exists. Overhead tasks, roofing tasks, excavations, roadwork activity, demolition work, and other recognized hazards shall have guardrail protection, warning barricades, or similar protective measures acceptable to the Authority's Project Manager. Signs, signals, and/or barricades shall be removed when the hazard no longer exists.

2.22 STEEL ERECTION

Steel Erection scope activity shall comply with 29 CFR Subpart R, Section 1926.750, and CCR Title 8 Standards. In addition to OSHA Standards, Contractor shall comply with the following requirements.

- A. Erection planning should incorporate installation methods using aerial devices (man-lifts) and elevated work platforms (scissor lift) to minimize fall hazards of climbing steel where possible. A detailed written job safety analysis (JSA) shall identify installation methods, equipment, and control methods to minimize potential fall hazards.
- B. The Contractor shall not allow any employee to walk the steel unprotected from falls. Contractor employees must be tied-off and "coon" the beam until safety cables are provided to which employees shall use 100% tie-off protection. Two lanyards are required to ensure 100% tie-off protection.
- C. A safe means of access to the level being worked shall be planned. Climbing and sliding down columns are not considered safe access and are forbidden on Authority projects.
- D. A qualified rigger shall inspect the rigging prior to each shift and each lift.
- E. Multiple lift rigging (Christmas Treeing) lifts are forbidden on Authority property and controlled projects.

2.23 AUDITS

- A. The Authority may make periodic patrols of the project site as a part of its normal security and safety program. The Contractor shall not be relieved of its aforesaid responsibilities and the Authority shall not assume same, nor shall it be deemed to have assumed, any responsibility otherwise imposed upon the Contractor, as a result of safety patrols by the Authority.

- B. The Authority may audit the Contractor's safety program for HSE compliance at various intervals of the project, at the sole discretion of the Authority. Elements may include, but are not limited to: OSHA injury & illness records and logs, Job Safety Analysis and safety plans, equipment operator licenses and training records, incident reports, meeting minutes, engineered plans, safety meeting records, crane and rigging plans, equipment inspection records, qualifications of and interviews with key Contractor management personnel, and other similar information. The Contractor shall support and cooperate with these audits at no additional compensation or schedule impacts with this contract.

2.24 RAILWAY SAFETY PRECAUTIONS

- A. Work on operating railways shall be in compliance with 49 CFR, Part 214, CCR Title 8 Standards, and the Southern California Regional Rail Authority (SCRRA).
- B. New construction rail projects require that all employers and contractors are responsible to assure employees are trained and understand on-track safety procedures, and follow roadway worker rules identified in 49 CFR, Part 214, CCR Title 8, SCRRA, the California Department of Transportation (CalTrans), and OCTA HSE Construction Management Requirements (i.e., item E references).
- C. Minimum PPE for workers include hard hat, safety glasses, orange (i.e., rail company approved color) class 2 reflective vest, safety toe footwear that meets ANSI Z41 1991 (lace-up type over the ankle) and hearing protection (on person and worn as necessary).

2.25 FINES

The Contractor shall be responsible for the payment of all fines levied against the Authority for HSE violations arising from or related to activities over which Contractor has responsibility per the contract.

2.26 COMPLIANCE COSTS

Compliance with Health, Safety and Environmental Compliance identified in these aforementioned Authority Safety Specifications shall be at the expense of the Contractor, and included in Bid Documents to the Authority for the Contractor's scope. The Authority shall incur no additional cost or schedule impacts by Contractor, for compliance with California Construction Safety Orders, CCR Title 8 Standards, Federal OSHA Standards, and the Authority Safety Specifications for the protection of persons and property.

2.27 REFERENCES

- A. CCR Title 8 Standards (Cal/OSHA)
- B. CFR Including 1910 and 1926 Standards
- C. NFPA, NEC, ANSI, NIOSH Standards
- D. USACE Construction Quality Management Manual (EM-385-1-1)
- E. Construction Industry Institute (CII)
- F. OCTA Construction Management Procedures Manual
- G. OCTA Yard Safety Rules

END OF DOCUMENT

**BID BOOKLET INVITATION FOR BID (IFB) 9-1787
BOOK 2 OF 2**

**METROLINK TRAIN STATIONS
PLATFORM DETECTABLE TILES
REPLACEMENT AND PAINTED
GUIDELINES RESTRIPIING PROJECT**



**ORANGE COUNTY TRANSPORTATION AUTHORITY
550 South Main Street
P.O. Box 14184
Orange, CA 92863-1584
(714) 560-6282**

Key IFB Dates

Issue Date:	April 27, 2020
Pre-Bid Conference/Site Visit:	May 6, 2020
Questions/Approved Equal Submittal:	May 11, 2020
Bids Submittal Date:	May 27, 2020

FEDERAL TRANSIT ADMINISTRATION FUNDED PROJECT



BID FORM

The undersigned hereby proposes to perform all work for which a contract may be awarded and to furnish any and all plant, labor, services, material, tools, equipment, supplies, transportation, utilities, and all other items and facilities necessary therefore as required in the **IFB 9-1787, "METROLINK TRAIN STATIONS PLATFORM DETECTABLE TILES REPLACEMENT AND PAINTED GUIDELINES RESTRIPIING PROJECT"**, and to do everything required therein; and further proposes that, if this bid is accepted, will contract in the form and manner stipulated to perform all the work in strict conformity therewith within the time limits set forth therein, and will accept as full payment therefore, the following price:

<u>Description</u>		Total Lump Sum <u>Bid Amount</u>
_____	\$	_____

A cashier's check/certified check/bid bond (circle applicable term) properly made payable to Orange County Transportation Authority, hereinafter designated as the Owner, for the sum of

_____ Dollars
 (\$ _____)

which amount is not less than ten percent (10%) of the total amount of this bid, is attached hereto and is given as a guarantee that the undersigned will execute the Agreement and furnish the required bonds, "Guaranty" and "Certificate of Insurance", if awarded the contract, and in case of failure to do so within the time provided, (a) the proceeds of said check shall be forfeited to the Authority; or (b) surety's liability to the Authority for forfeiture of the face amount of the bond shall be considered as established [circle (a) or (b)].

The undersigned hereby represents that:

BID FORM, PAGE 2

1. Bidder has thoroughly examined and become familiar with the work required and documents included under this IFB. The bidder understands that the award of the contract, if it is awarded, will be based on the lowest total bid submitted by a responsive and responsible bidder, and further, that the amounts and the total on the Bid Form will be subject to verification by the Authority.
2. By investigation at the site of the work and otherwise, it is satisfied as to the nature and location of the work and is fully informed as to all conditions and matters, which can in any way affect the work or the cost thereof.
3. Bidder fully understands the scope of the work/specifications and has checked carefully all words and figures inserted in said Invitation for Bids (IFB) and further understands that the Authority will in no way be responsible for any errors or omissions in the preparation of this bid. Bidder further asserts that it is capable of performing quality work to meet Authority's requirements.
4. Bidder fully understands the requirements of the Level 3 Safety Specifications inserted in said IFB and has included the costs of full compliance with these requirements in its bid. Bidder understands that it will not be allowed to mobilize until satisfying the requirements of the Level 3 Safety Specifications.
5. Bidder will execute the Agreement and furnish the required Performance and Payment Bonds, Guaranty and proof of insurance coverage within ten (10) calendar days after notice of acceptance of bid by the Authority; and further, that this bid may not be withdrawn for a period of 120 calendar days after the date set for the opening thereof, unless otherwise required by law. If any bidder shall withdraw its bid within said period, the bidder shall be liable under the provisions of the Bid Security, or the bidder and the surety shall be liable under the Bid Bond, as the case may be.
6. Bidder hereby certifies that this bid is genuine and not a sham or collusive or made in the interest or on behalf of any person not herein named, and the undersigned has not directly or indirectly induced or solicited any other bidder to put in a sham bid, or any other person, firm, or corporation to refrain from bidding; the undersigned has not in any manner sought by collusion to secure for himself an advantage over any other bidder.
7. In conformance with current statutory requirements of Section 1860, et. seq., of the Labor Code of the State of California, the bidder shall execute the document included in this IFB entitled "Bidder's Certificate of Compliance Regarding Workers' Compensation Insurance."
8. Bidder hereby further certifies that each, and every representations made in this bid are true and correct and made under penalty of perjury.

BID FORM, PAGE 3

9. Bidder shall permit the authorized representative of the Authority to inspect and audit all data and records of bidder relating to this bid, and if awarded a contract resulting from this bid, shall permit such inspection and audit of all data and records of bidder related to bidder's performance of such contract.
10. Bidder does not employ anyone who is now, or for one (1) year immediately prior to the date of this offer was, a director, officer, member, or employee of the Orange County Transportation Authority. The undersigned has not agreed to pay a fee contingent upon the award of a contract resulting from this bid to anyone who is now, or for one (1) year immediately prior to the date of this bid was, a director, officer, member, or employee of the Orange County Transportation Authority. No member of or delegate to the Congress of the United States shall be admitted to any share of the contract or to any benefit arising therefrom.
11. If awarded a contract resulting from this bid, bidder shall not discriminate against any employee or applicant for employment because of race, religion, color, sex, age or national origin. The bidder shall take affirmative action to ensure that applicants are employed, and that employees are treated during their employment, without regard to their race, religion, color, sex, age or national origin. Such actions shall include, but not be limited to the following: employment, upgrading, demotion, or transfer; recruitment or recruitment advertising; layoff or termination; rates of pay or other forms of compensation; and selection for training, including apprenticeship.
12. If awarded a contract resulting from this bid, bidder will cooperate with the Authority in meeting commitments and goals with regard to the maximum utilization of DBE firms and will use its best efforts to ensure that DBE firms shall have the maximum practicable opportunity to compete for subcontract work under such contract.
13. Bid will be in effect for 120 calendar days after the bid closing date.

BID FORM, PAGE 4

Now: In compliance with the **Invitation For Bids (IFB) 9-1787, "METROLINK TRAIN STATIONS PLATFORM DETECTABLE TILES REPLACEMENT AND PAINTED GUIDELINES RESTRIPIING PROJECT"**, the undersigned, with full cognizance thereof, hereby proposes to perform the entire work in strict compliance with all of the said requirements and provisions for the prices set forth herein upon which award of contract is made. The undersigned affirms that the information provided herein is true and accurate and that any misrepresentations are made under penalty of perjury.

Dated _____, 2020 Bidder _____

The above bid includes Signature _____

Addenda Nos. _____ Name _____

Title _____

Bidder's Authorized Representative _____

Title _____

Telephone # _____

Fax # _____

Email Address _____

Bidders post office address _____

Corporation organized under the laws of the State of _____

Contractor's License No. _____

Expiration Date of License _____

Surety or sureties _____

(CORPORATE SEAL)

BID SECURITY FORM
BID BOND

KNOW ALL MEN BY THESE PRESENTS:

That, _____ as principal and Bidder and _____ as Surety, are held and firmly bound unto the Orange County Transportation Authority, of State of California, hereinafter referred to as "Authority," in the sum of _____ Dollars (\$ _____), to be paid to the Authority, its successors, and assigns; for which payment, well and truly to be made, bind themselves, their heirs, executors, administrators, successors, and assigns, jointly and severally, firmly by these presents, this amount being ten percent (10%) of the total amount of the Bid.

THE CONDITION OF THIS OBLIGATION IS SUCH, that if the certain bid of the above named _____ bounden _____ principal _____

for _____ at the Orange County Transportation Authority's _____ as specifically set forth in documents entitled **IFB 9-1787, "METROLINK TRAIN STATIONS PLATFORM DETECTABLE TILES REPLACEMENT AND PAINTED GUIDELINES RESTRIPIING PROJECT"**, shall not be withdrawn within a period of 120 calendar days after the date set for the opening of bids, (unless otherwise required by law, and notwithstanding the award of the contract to another Bidder), and that if said bid is accepted by the Authority through action of its legally constituted contracting authorities and if the above bounden _____ its heirs, executors, administrators, successors and assigns, shall execute a contract for such construction and deliver the required Performance and Payment Bonds, , "Guaranty," and proof of insurance coverage within ten (10) calendar days after notification of contract award from the Authority, then this obligation shall become null and void; otherwise it shall be and remain in full force and effect.

IN WITNESS WHEREOF, we hereunto set our hands and seals this _____ day of _____, 2020.

NOTE: The standard printed bond form of any bonding company acceptable to the Authority may be used in lieu of the foregoing approved sample bond form provided the security stipulations protecting the Authority are not in any way reduced by use of the security company's printed standard form.

BID SECURITY FORM
CHECK TO ACCOMPANY BID

(NOTE: The following form shall be used in case check accompanies bid)

Accompanying this bid is a Certified or Cashiers check (circle the appropriate one) payable to the order of Orange County Transportation Authority, hereinafter referred to as "Authority" for _____ dollars (\$_____), this amount being ten percent (10%) of the total amount of the Bid submitted in response to **IFB 9-1787, "METROLINK TRAIN STATIONS PLATFORM DETECTABLE TILES REPLACEMENT AND PAINTED GUIDELINES RESTRIPIING PROJECT"**. The proceeds of this check shall become the property of Authority provided this bid shall be accepted by Authority through action of its legally constituted contracting authorities and the undersigned shall fail to execute a contract and furnish the required Guaranty Form, Performance and Payment Bonds and proof of insurance coverage within ten (10) calendar days after date of notification of contract award from the Authority. The proceeds of this check shall also become the property of the Authority if the undersigned bidder withdraws the bid within the period of 120 days after the date set for the opening thereof, unless otherwise required by law, and notwithstanding the award of the contract to another bidder. Otherwise, the check shall be returned to the undersigned.

Bidder: _____

Signature: _____

Date: _____

NOTE: If the bidder desires to use a bond instead of check, the Bid Bond form shall be executed and the sum of this bond shall be ten percent [10%] of the total amount of the bid.

INFORMATION REQUIRED OF BIDDER

The bidder is required to supply the following information. Additional sheets may be attached if necessary.

1. Name of Bidder: _____
2. Business Address: _____
3. Telephone () _____ Fax () _____ E-Mail: _____
4. Type of Firm - Individual, Partnership or Corporation: _____
5. Corporation organized under the laws of state of: _____
6. Contractor's License No.: _____ Class: _____ Years of Experience: _____
7. Expiration Date of License: _____
8. Is your firm a certified small business in California? Yes____ No____
9. List the names and addresses of all owners of the firm or names and titles of all officers of the corporation:

INFORMATION REQUIRED OF BIDDER, PAGE 2

10. Please list the following: a) All prior and current license numbers that the current owner(s) or officers possess or have possessed in the last five years and the current status of those license; b) any prior company names that the owner(s) had in operation during the previous five years.

Current Officers or Owners Name	Prior Company Names (During the last 5 years)	Prior and Current License Numbers	Status of License

Note: If additional space is required to detail the information requested, please attach another page. All information requested must be included. Failure to identify all of the information may result in your bid being found non-responsive and your bid being rejected.

11. List all construction projects (public and private) for which Bidder has provided general contractor services for the past three years:

Contract Type (Public or Private)	Project Description	Dates of Service	Total Cost	Name and Address of Owner	Contact Name, Email Address and Phone Number

Note: If additional space is required to detail the information requested, please attach another page. All information requested must be included. Failure to identify all of the information, may result in your bid being found non-responsive and your bid being rejected.

12. List the name, address and phone number of Superintendent for this project:

13. List all construction projects (public and private) for which Superintendent has provided services as a Superintendent for the past three years.

Contract Type (Public or Private)	Project Description	Dates of Service	Total Cost	Name and Address of Owner	Contact Name, Email Address and Phone Number

Bidder hereby certifies that it:

_____ is a certified Disadvantaged Business Enterprise as defined herein.

_____ is not a Disadvantaged Business Enterprise as defined herein.

NOTE: If requested by the Authority, bidder shall furnish a certified financial statement, financial data, or other information and references sufficiently comprehensive to permit an appraisal of its current financial condition.

I hereby certify the above is true and correct to the best of my belief.

Signature

Name

Title

Company Name

Telephone Number

Fax Number

Email Address

**NOTICE OF REQUIREMENT FOR AFFIRMATIVE ACTION TO ENSURE
EQUAL EMPLOYMENT OPPORTUNITY (EXECUTIVE ORDER 11246)**

1. The Bidders' attention is called to the "Equal Opportunity Clause" and the "Standard Federal Equal Employment Opportunity Construction Contract Specifications" set forth herein.
2. The goals and timetables for minority and female participation, expressed in percentage terms for the Contractor's aggregate work force in each trade on all construction work in the covered area, are as follows:

Timetable Goals for Minority Participation for Each Trade (11.9)

Goals for Female Participation in Each Trade (6.9)

These goals are applicable to all the Contractor's construction work (whether or not it is federal or federally assisted) performed in the covered area.

The Contractor's compliance with the Executive Order and the regulations in 41 C.F.R. Part 60-4 shall be based on its implementation of the Equal Opportunity Clause, specific affirmative action obligations required by the specifications set forth in 41 C.F.R. 60-4.3 (a), and its efforts to meet the goals established for the geographical area where the contract resulting from this solicitation is to be performed. The hours of minority and female employment and training must be substantially uniform throughout the length of the contract, and in each trade, and the Contractor shall make a good faith effort to employ minorities and women evenly on each of its projects. The transfer of minority or female employees or trainees from contractor to contractor or from project to project for the sole purpose of meeting the contractor's goals shall be a violation of the contract, the Executive Order and the regulations in 41 C.F.R. Part 60-4. Compliance with the goals will be measured against the total work hours performed.

3. The Contractor shall provide written notification to the Director of the Office of Federal Contract Compliance Programs within ten (10) working days of award of any construction subcontract in excess of \$10,000 at any tier for construction work under the contract resulting from this solicitation. The notification shall list the name, address and telephone number of the subcontractor; employer identification number; estimated dollar amount of the subcontract; estimated starting and completion dates of the subcontract; and the geographical area in which the contract is to be performed.
4. As used in this Notice, and in the contract resulting from this solicitation, the "covered area" includes the County of Orange, California.

BIDDER'S CERTIFICATE OF COMPLIANCE
REGARDING
WORKERS' COMPENSATION INSURANCE

In conformance with current statutory requirements of Section 1860, et. seq., of the Labor Code of the State of California, the undersigned confirms the following certification:

"I am aware of the provisions of Section 3700 of the Labor Code which require every employer to be insured against liability for Workers' Compensation or to undertake self-insurance in accordance with the provisions of that code and I will comply with such provisions before commencing the performance of the work of this Contract."

Bidder/Contractor: _____

Signature: _____

Name and Title: _____

Date: _____

BIDDER'S CERTIFICATE OF COMPLIANCE
REGARDING
STATE OF CALIFORNIA
BUSINESS AND PROFESSIONS CODE SECTION 7028.15

Contractor License Number: _____

Expiration Date of Contractor's License: _____

Each, every and all of the representations made by Bidder in the attached bid are true and correct.

Name of Bidder/Contractor: _____

Signed: _____

Title: _____

Subscribed to and sworn before me, a Notary Public in and for the State of California, on _____, 2020.

Notary Public

My commission expires on:

_____, 2020
(NOTARY SEAL)

LIST OF SUBCONTRACTORS (EXHIBIT D)

List only the subcontractors, which will perform work or labor or render services to the bidder in excess of one-half of one percent (1/2 of 1%) of the bidder's total bid amount. Do not list alternative subcontractors for the same work. (Use additional sheets if necessary.)

Name & Address Under Which Subcontractor is Licensed	License Number	DIR Registration No.	Specific Description of Work to be Rendered	Small Business Y/N	Type	Dollar Amount
						\$
						\$
						\$
						\$
						\$
						\$
TOTAL VALUE OF SUBCONTRACTED WORK						\$

Bidder's Name _____

STATUS OF PAST AND PRESENT CONTRACTS FORM

On the form provided below, Offeror/Bidder shall list the status of past and present contracts where the firm has either provided services as a prime vendor or a subcontractor during the past five (5) years in which the contract has been the subject of or may be involved in litigation with the contracting authority. This includes, but is not limited to, claims, settlement agreements, arbitrations, administrative proceedings, and investigations arising out of the contract.

A separate form must be completed for each contract. Offeror/Bidder shall provide an accurate contact name and telephone number for each contract and indicate the term of the contract and the original contract value. Offeror/Bidder shall also provide a brief summary and the current status of the litigation, claims, settlement agreements, arbitrations, administrative proceedings, or investigations. If the contract was terminated, list the reason for termination.

Offeror/Bidder shall have an ongoing obligation to update the Authority with any changes to the identified contracts and any new litigation, claims, settlement agreements, arbitrations, administrative proceedings, or investigations that arise subsequent to the submission of the bid. Each form must be signed by an officer of the Offeror/Bidder confirming that the information provided is true and accurate.

Project city/agency/other:	
Contact Name:	Phone:
Project Award Date:	Original Contract Value:
Term of Contract:	
(1) Litigation, claims, settlements, arbitrations, or investigations associated with contract:	
(2) Summary and Status of contract:	
(3) Summary and Status of action identified in (1):	
(4) Reason for termination, if applicable:	

By signing this Form entitled "Status of Past and Present Contracts," I am affirming that all of the information provided is true and accurate.

Name

Signature

Title

Date

Non-Collusion Declaration to be Executed by Bidder and Submitted with Bid

To the Orange County Transportation Authority
The undersigned declares:

I am the _____ of _____, the party making the foregoing bid. In accordance with Title 23 United States Code Section 112 and Public Contract Code Section, 7106 the bidder declares that the bid is not made in the interest of, or on the behalf of, any undisclosed person, partnership, company, association, organization or corporation. The bid is genuine and not collusive or sham. The bidder has not directly or indirectly induced or solicited any other bidder to put in a false or sham bid, or that anyone shall refrain from bidding. The bidder has not in any manner, directly or indirectly, sought by agreement, communication, or conference with anyone to fix the bid price of the bidder or any other bidder, or to fix any overhead, profit, or cost element of the bid price, or of that of any bidder, or to secure any advantage against the public body awarding the contract of anyone interested in the proposed contract. All statements contained in the bid are true. The bidder has not, directly, or indirectly, submitted his or her bid price or any breakdown thereof, or the contents thereof, or divulged information or data relative thereto, or paid, and will not pay, any fee to any corporation, partnership, company, association, organization, bid depository, or to any member or agent thereof to effectuate a collusive or sham bid, and has not paid, and will not pay, any person or entity for such purpose.

Any person executing this declaration on behalf of a bidder that is a corporation, partnership, joint venture, limited liability company, limited liability partnership, or any other entity, hereby represents that he or she has full power to execute, and does execute, this declaration on behalf of the bidder.

I declare under penalty of perjury under the laws of the State of California that the foregoing is true and correct and that this declaration is executed on _____ (date), at _____ (city), _____ (state).

Name of Bidder: _____

Signature: _____

Date: _____



DBE PARTICIPATION COMMITMENT FORM

THIS FORM MUST BE COMPLETED AND SUBMITTED WITH THE BID AS A CONDITION OF DBE RESPONSIVENESS

NOTE: Refer to instructions on the reverse side of this form.

Bidder to Complete this Section

1. IFB No.: _____
2. Project Name/Description: _____
3. Prime Bidder Name: _____
4. Contract DBE Goal %: _____
5. Bidder's Total Bid Price _____

Required DBE Commitment Information

6. DBE Firm (Name and Address)	7. DBE Certification Number	8. Description of Scope of Services/Work	9. Bid Item (#)	10. Dollar Value (\$) of Participation	11. Dollar Value (\$) of Eligible DBE Participation/ Commitment

Note: As a condition of responsiveness, the bidder is required to submit with the Bid a written confirmation signed and dated from each DBE listed in Column 6 acknowledging that the DBE is participating in the contract for the specified dollar value (\$) and scope of work.

A quote or bid from the DBE firm can serve in lieu of the written confirmation; however, the dollar amount in the written confirmation, quote/bid and the amount shown on this form MUST match identically.

12. Total Dollar Value (\$) of Eligible DBE Participation
\$ _____

13. Eligible DBE Participation Represented as a Percentage (%) of Bidder's Total Bid Price
_____ %

Bidder Assurance: The bidder certifies that information on this form is complete and accurate, that it has verified the listed DBE(s) certification status and is only crediting eligible DBE participation towards meeting the contract DBE goal.

14. Preparer's Name (Print)

15. Preparer's Signature

16. Preparer's Title

17. Date

18. Telephone No.

19. Email Address

INSTRUCTIONS - DBE Participation Commitment Form

Bidder is required to ensure all information is complete and accurate:

1. **IFB No.** - Enter the IFB Number.
2. **Project Name/Description** - Enter the name and/or description of the project.
3. **Prime Bidder Name** - Enter the bidder's firm name.
4. **Contract DBE Goal %** - Enter the contract DBE goal percentage.
5. **Bidder's Total Bid Price** – Enter the bidder's total bid price.
6. **DBE Firm** – Enter name and address of the proposed DBE firm. Identify all DBE firms being claimed for credit, regardless of tier.
7. **DBE Certification Number** - Enter the DBE's certification identification number. All DBEs must have a valid DBE certification at time of bid opening.
8. **Description of Scope of Services/Work** – Enter the scope of services/work for each DBE firm listed to participate on this contract.
9. **Bid Item (#)** - Enter bid item number.
10. **Dollar Value (\$) of Participation** - Enter the total dollar value of participation for each listed DBE firm.
11. **Dollar Value (\$) of Eligible DBE Participation/Commitment** - Enter the dollar value of participation eligible to count towards meeting the contract DBE goal. This value should exclude work performed by lower tier subcontractors and account for the DBE's capacity based on their certification type in conformance with the DBE crediting provisions set forth in Title 49 CFR Part 26.55.
12. **Total Dollar Value (\$) of Eligible DBE Participation** - Enter the sum of all eligible participation listed in column 11.
13. **Eligible DBE Participation Represented as a Percentage (%) of Bidder's Total Bid Price** - Enter the corresponding percentage of the total eligible DBE participation that the bidder is counting towards the bidder's DBE goal commitment (Formula: Item (12) Total Value of Eligible DBE Participation / Item (5) Bidder's Total Bid Price = Bidder's DBE Goal Commitment Percent (%)).
14. **Preparer's Name (Print)** - Clearly enter the name of the authorized person preparing the form on behalf of the bidder.
15. **Preparer's Signature** - Authorized person's signature.
16. **Preparer's Title** - Enter the position/title of the authorized person signing the form on behalf of the bidder.
17. **Date** - Enter the date the form is signed.
18. **Telephone No.** - Enter the area code and telephone number of the authorized person signing the form on behalf of the bidder.
19. **Email Address** - Enter the email address of the authorized person signing the form on behalf of the bidder.

NOTE: A firm is only eligible to count towards DBE participation in the NAICS codes contained within its California Unified Certification Program (CUCP) DBE Profile. Bidders are to verify that listed DBE's certification contains the NAICS codes relevant to the scope they are being listed to perform.



DBE INFORMATION - GOOD FAITH EFFORTS

IFB No: _____ Bid Opening Date _____

The Orange County Transportation Authority (Authority) established a Disadvantaged Business Enterprise (DBE) goal of _____% for this contract. The information provided herein shows that a good faith effort was made by _____(Bidder).

Bidder shall submit the following information to document adequate good faith efforts to the Authority no later than 4:00 p.m. on the 2nd business day after the Authority's bid due date, or as otherwise specified in the solicitation. Bidder should submit the following information even if the "DBE Participation Commitment Form" indicates that the bidder has met the DBE goal. This will protect the bidder's eligibility for award of the contract if Authority determines that the bidder failed to meet the goal for various reasons, e.g., a DBE firm was not certified at bid opening, or the bidder made a mathematical error.

Submittal of only the form may not provide sufficient documentation to demonstrate that adequate good faith efforts were made.

The following good faith efforts items (A through H) shall be minimally performed prior to bid submission. Bidder to complete the following items in sufficient detail to effectively demonstrate that good faith efforts were undertaken to meet the established DBE goal:

- I. Items of Work the Bidder Made Available to DBE Firms; a description of work items and approximate dollar amounts made available to DBE firms by the bidder, value of work items as a percentage of total contract work, breakdown of bid items or larger scopes of contract work (including those items normally performed by the bidder with its own forces) into economically feasible units to facilitate DBE participation sufficient to meet the DBE contract goal. It is the bidder's responsibility to demonstrate that sufficient work was made available to facilitate DBE participation as follows (Provide documents that sufficiently evidence the efforts detailed below):

Description of Work Item	Bidder Normally Performs (Y/N)	Unbundled from Larger Scope (Y/N) If Yes, List Scope and/or Bid Item (#)	Amount (\$)	Percentage of Contract

- J. Solicitation Effort Documentation; the names and dates of written notices sent to certified DBEs soliciting bids for this project and the dates and methods used to following up initial solicitations to determine with certainty whether the DBEs were interested (attach all copies of solicitation, telephone records, fax confirmations, email communications, etc.), amount of DBEs to repond, documentation to demonstrate the DBE firms were provided information about the contract (location of project, contract number, bid date, items of work made available and contact information) in the Invitation to Bid from the bidder, the bidder solicited through all reasonable means (e.g. attendance at pre-bid meetings, advertising and written notices) the interest of all certified DBEs who have the capability to perform the work of the contract, bidder to provide proof of aforementioned items, and DBEs in the market area for the work identified in 'Item A' as follows:

DBE Firm	Contact Name/Title	Method of Solicitation	Date of Initial Solicitation	Date of Follow-Up Solicitation	Response/ Interested in Bidding

(Note: Solicitations should occur at a minimum no later than 14 calendar days prior to the Authority's bid due date and follow up to the solicitation should allow DBE firms reasonable time to respond). DBE firms solicited must be advised if the original bid date has been extended.

- K. Rejected DBE Bid Documentation; the names, addresses, phone numbers, and amount of rejected DBE firms, the reasons for the bidder's rejection of the DBE firms, the firms selected and accepted for that work (attach all copies of quotes from the firms involved inclusive of a detailed cost breakdown if opted to self-perform work) and the price difference for each DBE if the selected firms is not a DBE, include an explanation of quote(s) rejected.
- L. Publication Efforts Made to Advertise the Projects to Solicit DBE Participation; names and dates of each publication in which a request for DBE participation for this project was placed by the bidder (attach copies of advertisements or proof of publications). Publications should be placed at a minimum 14 calendar days before the Authority's bid due date. If bid due date is extended, bidder is to re-advertise new bid due date.

Publications	Type of Publication (Trade/General/Minority/Focus)	Dates of Advertisement	Duration of Advertisement	Readvertisement (Bid-Due Date Extension)

- M. Agencies, Organizations, or Groups Contacted to Provide Assistance in Contracting, Recruiting, and Using DBEs; the names of agencies, organizations or groups contacted to provide assistance in contacting, recruiting and using DBE firms (Attach copies of requests to agencies, responses received and efforts made by the bidder in response).

- N. Efforts to Provide Information About the Plans, Specifications, and Contract Requirements; efforts made to assist interested DBEs in obtaining necessary materials, or related assistance or services, bidder to provide evidence of effort.

- O. Assistance with Lines of Credit, Insurance, and/or other Services; efforts made to assist interested DBEs in obtaining bonding, lines of credit or insurance, and any technical assistance or information related to the plans, specifications and requirements for the work which was provided to DBEs, bidder to provide a list of any assistance provided to prospective and bided DBEs:

- P. Additional Data to Support a Demonstration of Good Faith Efforts; in determining whether a bidder made adequate good faith efforts, the Authority will take into account the performance of other bidders in meeting the DBE contract goal. Attach any additional information to support demonstration of good faith in this section:

NOTE: USE ADDITIONAL SHEETS AS NECESSARY TO DEMONSTRATE RESPONSIVENESS.



Bidders List

The Department of Transportation requires the Authority to create and maintain a "Bidders List" containing information about all firms (DBE and Non-DBE) that bid, propose or quote on the Authority's DOT-assisted contracts, in accordance with 49 CFR Part 26.11. The "Bidders List" is intended to be a count of all firms that are participating, or attempting to participate, on DOT-assisted contracts, whether successful or unsuccessful in their attempt to obtain a contract.

The bidder is to complete all requested information for every firm who submitted a bid, proposal or quote, including the primary bidder, and submit this information to the Authority no later than 4:00 p.m. on the 2nd business day after the Authority's bid due date, or as otherwise specified in the solicitation. The Authority will utilize this information to assist in the Authority's DBE goal-setting process.

Prime Name and Location	Type of Work/Services/Materials Provided:	Subcontract Amount	Percentage of Bid Item Sub-contracted	Contractor License No.	DBE (Y/N)	Phone:	Annual Gross Receipts
	NAICS/WCC			DIR Reg Number	DBE Certification ID	E-mail:	
Prime Bidder:							<input type="checkbox"/> Less than \$1 million <input type="checkbox"/> Less than \$5 million <input type="checkbox"/> Less than \$10 million <input type="checkbox"/> Less than \$15 million <input type="checkbox"/> More than \$15 million Age of Firm: _____yrs.
Contact Name:							
Address:							

Subcontractor Name and Location	Type of Work/Services/Materials Provided:	Subcontract Amount	Percentage of Bid Item Sub-contracted	Contractor License No.	DBE (Y/N)	Phone:	Annual Gross Receipts
	NAICS/WCC			DIR Reg Number	DBE Certification ID	E-mail:	
Firm Name:							<input type="checkbox"/> Less than \$1 million <input type="checkbox"/> Less than \$5 million <input type="checkbox"/> Less than \$10 million <input type="checkbox"/> Less than \$15 million <input type="checkbox"/> More than \$15 million Age of Firm: _____yrs.
Contact Name:							
Address:							

**IFB 9-1787
EXHIBIT E-3**

Subcontractor Name and Location	Type of Work/Services/Materials Provided:	Subcontract Amount	Percentage of Bid Item Sub-contracted	Contractor License No.	DBE (Y/N)	Phone:	Annual Gross Receipts
	NAICS/WCC			DIR Reg Number	DBE Certification ID	E-mail:	
Firm Name:							<input type="checkbox"/> Less than \$1 million
Contact Name:							<input type="checkbox"/> Less than \$5 million
Address:							<input type="checkbox"/> Less than \$10 million
							<input type="checkbox"/> Less than \$15 million
							<input type="checkbox"/> More than \$15 million
							Age of Firm: _____yrs.
Firm Name:							<input type="checkbox"/> Less than \$1 million
Contact Name:							<input type="checkbox"/> Less than \$5 million
Address:							<input type="checkbox"/> Less than \$10 million
							<input type="checkbox"/> Less than \$15 million
							<input type="checkbox"/> More than \$15 million
							Age of Firm: _____yrs.
Name:							<input type="checkbox"/> Less than \$1 million
Contact Name:							<input type="checkbox"/> Less than \$5 million
Address:							<input type="checkbox"/> Less than \$10 million
							<input type="checkbox"/> Less than \$15 million
							<input type="checkbox"/> More than \$15 million
							Age of Firm: _____yrs.

NOTE: USE ADDITIONAL SHEETS AS NECESSARY TO DEMONSTRATE RESPONSIVENESS TO THE BIDDERS LIST REQUIREMENTS.

IRAN CONTRACTING ACT CERTIFICATION

(California Public Contract Code Sections 2200, *et seq.*)

The Iran Contracting Act of 2010 (PCC Sections 2200-2208), prohibits bidders who are engaged in investment activities in the energy sector of Iran from bidding on, submitting proposals for, or entering into or renewing contracts with public entities for goods or services of one million dollars (\$1,000,000) or more. At the time of submitting a bid, each bidder must certify that the bidder is not identified on the Department of General Services list of ineligible persons pursuant to PCC Section 2203(b). Each bidder is also required to certify that the bidder is not engaged in investment activities in violation of the Iran Contracting Act of 2010.

A bidder who is engaged in investment activities in the energy sector of Iran is defined as:

3. A person providing goods or services of twenty million dollars (\$20,000,000) or more in the energy sector of Iran, including a person that provides oil or liquefied natural gas tankers, or products used to construct or maintain pipelines used to transport oil or liquefied natural gas, for the energy sector of Iran; or
4. A person that is a financial institution that extends twenty million dollars (\$20,000,000) or more in credit to another person, for 45 days or more, if that person will use the credit to provide goods or services in the energy sector in Iran and is identified on a list created pursuant to PCC Section 2203(b).

A bidder is not required to certify that it is engaged in investment activities in the energy sector of Iran if the bidder is exempt from the certification under PCC Section 2203(c) or (d). If the bidder is exempt from the certification requirement, the bidder will be required to provide documentation demonstrating the exemption.

To comply with the Iran Contracting Act of 2010, the bidder shall complete **one** of the options below. Please note: under PCC Section 2205, false certification of this form may result in civil penalties of \$250,000 or twice the amount of the contract for which false certification was made, termination of the contract, and/or ineligibility to bid on contracts for a period of three years.

Option #1: Certification

I, the official named below, certify I am duly authorized to execute this certification on behalf of the vendor/financial institution identified below, and the vendor/financial institution identified below, and any subcontractor who will perform work or labor or render services to the vendor identified below, is not on the current Department of General Services list identifying persons engaged in investment activities in the energy sector of Iran, and is not a financial institution extending twenty million dollars (\$20,000,000) or more in credit to another person/vendor, for 45 days or more, if that other person/vendor will use the credit to provide goods or services in the energy sector in Iran and is identified on the current Department of General Services list identifying persons engaged in investment activities in the energy sector of Iran.

Vendor/Financial Institution: _____

Signature: _____

Name and Title: _____

Date: _____

Option #2: Exemption

Pursuant to PCC Section 2203(c) and (d), a public entity may permit a bidder or financial institution engaged in investment activities in Iran, on a case-by-case basis, to be eligible for, or to bid on, submit proposals for, or enter into or renew a contract with a public entity for goods or services of one million dollars (\$1,000,000) or more. If the bidder, financial institution, or any subcontractor who will perform work or labor or render services to the bidder has obtained an exemption from the certification requirement, please complete and sign below and attach the documentation demonstrating the exemption approval.

Vendor/Financial Institution: _____

Signature: _____

Name and Title: _____

Date: _____

Option #3: Non-Applicability

Pursuant to PCC Section 2203(b), a bidder or financial institution engaged in investment activities in Iran may not be eligible for, or to bid on, submit proposals for, or enter into or renew a contract with a public entity for goods or services of one million dollars (\$1,000,000) or more. If the contract is not for goods or services of one million dollars (\$1,000,000) or more, please sign below indicating that the contract is not for goods or services of one million dollars (\$1,000,000) or more and thus bidder is not required to certify and does not meet the exemption.

Vendor/Financial Institution: _____

Signature: _____

Name and Title: _____

Date: _____

BIDDER'S CERTIFICATE
REGARDING
"BUY AMERICA" REQUIREMENTS
FOR
STEEL, IRON, OR MANUFACTURED PRODUCTS

In order to demonstrate compliance with the Buy America Requirements, if the bid is for a contract greater than one hundred and fifty thousand dollars (\$150,000), Bidder shall complete only one of the two statements below:

The _____
 Firm name/principal

hereby certifies that it **will comply** with the requirements of 49 U.S.C. Section 5323(j), and the applicable regulations in 49 CFR Part 661.

 Signature

 Name

 Title

 Date

Or:

The _____
 Firm name/principal

hereby certifies that it **cannot comply** with the requirements of 49 U.S.C. Section 5323(j), but may qualify for an exception to the requirement pursuant to 49 U.S.C. Section 5323(j)(2), as amended, and the applicable regulations in 49 CFR Part 661.7.

 Signature

 Name

 Title

 Date

Revised: 05/23/2018

CERTIFICATION
LIMITATION ON PAYMENTS TO INFLUENCE CERTAIN
FEDERAL TRANSACTIONS

A. DEFINITIONS

1. Authority, as used in this clause, means the Orange County Transportation Authority.
2. Covered Federal action, as used in this clause, means any of the following Federal actions:
 - a. The awarding of any Federal contract.
 - b. The making of any Federal grant.
 - c. The making of any Federal loan.
 - d. The entering into of any cooperative agreement.
 - e. The extension, continuation, renewal, amendment, or modification of any Federal contract, grant, loan, or cooperative agreement.
 - f. Indian tribe and tribal organization, as used in this clause, have the meaning provided in Section 450b of the Indian self-determination and Education Assistance Act (25 U.S.C. 450) and include Alaskan Natives.
3. Influencing or attempting to influence, as used in this clause, means making, with the intent to influence, any communication to or appearance before an officer or employee of any agency, a Member of Congress, an officer or employee of Congress, or an employee of a Member of Congress in connection with any covered Federal action.
4. Local government, as used in this clause, means a unit of government in a State and, if chartered, established, or otherwise recognized by a State for the performance of a governmental duty, including a local public authority, a special district, an intrastate district, a council of governments, a sponsor group representative organization, and any other instrumentality of a local government.
5. Officer or employee of an agency, as used in this clause, includes the following individuals who are employed by an agency:
 - a. An individual who is appointed to a position in the Government under title 5, United States code, including a position under a temporary appointment.

- b. A member of the uniformed services, as defined in the subsection 101(3), Title 37, United States Code.
 - c. A special Government employee, as defined in Section 202, Title 18, United States Code.
 - d. An individual who is a member of a Federal advisory committee, as defined by the Federal Advisory Committee Act, Title 5, United States Code, Appendix section 3.
6. Person, as used in this clause, means an individual, corporation, company, association, authority, firm, partnership, society, State, and local government, regardless of whether such entity is operated for profit, or not for profit. This term excludes an Indian tribe, tribal organization or any other Indian organization with respect to expenditures specifically permitted by other Federal law.
 7. Reasonable compensation, as used in this clause, means with respect to a regularly employed officer or employee of any person, compensation that is consistent with the normal compensation for such officer or employee for work that is not furnished to, not funded by, or not furnished in cooperation with the Federal Government.
 8. Reasonable payment, as used in this clause means, with respect to professional and other technical services, a payment in an amount that is consistent with the amount normally paid for such services in the private sector.
 9. Recipient, as used in this clause, includes the Contractor and all subcontractors. This term excludes an Indian tribe, tribal organization, or any other Indian organization with respect to expenditures specifically permitted by other Federal law.
 10. Regularly employed, as used in this clause, means, with respect to an officer or employee of a person requesting or receiving by such person for at least 130 working days within one year immediately preceding the date of the submission that initiates agency consideration of such person for receipt of such contract. An officer or employee who is employed by such person for less than 130 working days within one year immediately preceding the date of the submission that initiates agency consideration of such person shall be considered to be regularly employed as soon as he or she is employed by such person for 130 working days.
 11. State, as used in this clause, means a State of the United States, the District of Columbia, the Commonwealth of Puerto Rico, a territory or possession of the United States, an agency or instrumentality of a State, and a multi-State regional or interstate entity having governmental duties and powers.

B. PROHIBITIONS

1. Section 1352 of Title 31, United States Code, among other things, prohibits a recipient of a Federal contract, grant, loan or cooperative agreement from using appropriated funds to pay any person for influencing or attempting to influence an officer or employee of any agency, a Member of Congress, an officer or employee of Congress, or an employee of a Member of Congress in connection with any of the following covered Federal actions: the awarding of any Federal contract; the making of any Federal grant; the making of any Federal loan; the entering into of any cooperative agreement; or, the modification of any Federal contract, grant, loan, or cooperative agreement.
2. The Act also requires Contractor to furnish a disclosure if any funds other than Federal appropriated funds (including profit or fee received under a covered Federal transaction) have been paid, or will be paid, to any person for influencing or attempting to influence an officer or employee of any agency, a Member of Congress, an officer or employee of Congress, or an employee of a Member of Congress in connection with a Federal contract, grant, loan or cooperative agreement.
3. The prohibitions of the Act do not apply under the following conditions:
 - a. Agency and legislative liaison by own employees.
 - (1) The prohibition on the use of appropriated funds, in subparagraph C.1. of this clause, does not apply in the case of payment of reasonable compensation made to an officer or employee of a person requesting or receiving a covered Federal action if the payment is for agency and legislative liaison activities not directly related to a covered Federal action.
 - (2) For purposes of paragraph C.3.a.(1) of this clause, providing any information specifically requested by an agency or Congress is permitted at any time.
 - (3) The following agency and legislative liaison activities are permitted any time where they are not related to a specific solicitation for any covered Federal action:
 - i. Discussing with an agency (including individual demonstrations) the qualities and characteristics of the person's products or services, conditions or terms of sale, and service capabilities.
 - ii. Technical discussions and other activities regarding the application of adaptation of the person's products or services for an agency's use.
 - (4) The following agency and legislative liaison activities are

technical discipline. For example, drafting of a legal document accompanying a bid or proposal is allowable. Similarly, technical advice provided by an engineer on the performance or operational capability of a piece of equipment rendered directly in the negotiation of a contract is allowable. However, communications with the intent to influence made by a professional (such as a licensed lawyer) or a technical person (such as a licensed accountant) are not allowable under this section unless they provide advice and analysis directly applying their professional or technical expertise and unless the advice or analysis is rendered directly and solely in the preparation, submission, or negotiation of a covered Federal action. Thus, for example, communications with the intent to influence made by a lawyer that do not provide legal advice or analysis directly and solely related to the legal aspects of his or her client's proposal, but generally advocate one proposal over another are not allowable under this section because the lawyer is not providing professional legal services. Similarly, communications with the intent to influence made by an engineer providing an engineering analysis prior to the preparation or submission of a bid or proposal are not allowable under this section since the engineer is providing technical services but not directly in the preparation, submission, or negotiation of a covered Federal action.

- iv. Requirements imposed by or pursuant to law as a condition for receiving a covered Federal award include those required by law or regulation and any other requirements in the actual award documents.
- v. Only those services expressly authorized by paragraph C.3.a.(1) and (2) of this clause are permitted under this clause.
- vi. The reporting requirements of FAR 3.803(a) shall not apply with respect to payments of reasonable compensation made to regularly employed officers or employees of a person.

d. Disclosure

- (1) The Contractor who requests or receives from an agency a Federal contract shall file with that agency a disclosure form OMB standard form LLL, Disclosure of Lobbying Activities, (Attachment to the bid package) if such person has made or had agreed to made any payment using non appropriated funds (to include

profits from any covered Federal action), which would be prohibited under subparagraph B.1. of this clause, if paid for with appropriated funds.

- (2) The Contractor shall file a disclosure form at the end of each calendar quarter in which there occurs any event that materially affects the accuracy of the information contained in any disclosure form previously filed by such person under subparagraph II.A. of this clause. An event that materially affects the accuracy of the information reported includes:
 - i. A cumulative increase of \$25,000 or more in the amount paid or expected to be paid for influencing or attempting to influence a covered Federal action; or
 - ii. A change in the person(s) or individual(s) influencing or attempting to influence a covered Federal action; or
 - iii. A change in the officer(s), employee(s), or Member(s) contacted to influence or attempt to influence a covered Federal action.
- (3) The Contractor shall require the submittal of a certification, and if required, a disclosure form by any person who requests or receives any subcontract exceeding \$100,000 under the Federal contract.
- (4) All subcontractor disclosure forms (but not certifications) shall be forwarded from tier to tier until received by the Contractor. The Contractor shall submit all disclosures to the District at the end of the calendar quarter in which the disclosure form is submitted by the subcontractor. Each subcontractor certification shall be retained in the subcontract file of the contractor.

- e. Agreement
 - (1) The Contractor agrees not to make any payment prohibited by this clause.

- f. Penalties
 - (1) Any person who makes an expenditure prohibited under paragraph a) of this clause or who fails to file or amend the disclosure form to be filed or amended by paragraph d) of this clause shall be subject to civil penalties as provided for by 31 U.S.C. 1352. An imposition of a civil penalty does not prevent the Government from seeking any other remedy that may be applicable.
 - (2) Contractor may relay without liability on the representation made by its subcontractors in the certification and disclosure forms.

- g. Cost Allowability:
 - (1) Nothing in this clause is to be interpreted to make allowable or reasonable any costs, which will otherwise be unallowable or unreasonable. Conversely, costs made specifically unallowable by the requirements in this clause will not be made allowable under any other provisions.

**CERTIFICATION OF
RESTRICTIONS ON LOBBYING**

I, _____, hereby certify on behalf (name of offeror) of _____ that:
(Firm name)

- A. No federal appropriated funds have been paid, by or on behalf of the undersigned, to any person for influencing or attempting to influence an officer or employee of any agency, a member of congress, an officer or employee of congress, or an employee of a member of congress in connection with the awarding of any federal contract, the making of any federal grant, the making of any federal loan, the entering into of any cooperative agreement, and the extension, continuation, renewal, amendment, or modification of any federal contract, grant, loan, or cooperative agreement.
 - 1. If any funds, other than Federal appropriated funds, have been paid or will be paid to any person for making lobbying contracts to an officer or employee of any agency, a Member of Congress, an officer or employee of Congress, or an employee of a Member of Congress in connection with this Federal contract, grant, loan, or cooperative agreement, the undersigned shall complete and submit the attached Standard Form-LLL, "Disclosure of Lobbying Activities", in accordance with its instructions.
 - 2. The undersigned shall require that the language of this certification be included in all subcontracts, and that all subcontractors shall certify and disclose accordingly.

This certification is a material representation of fact upon which reliance is placed when this transaction was made or entered into. Submission of this certification is a prerequisite for making or entering into this transaction imposed by Section 1352, title 31, U.S. Code. Any person who fails to file the required certification shall be subject to civil penalty of not less than \$10,000 and not more than \$100,000 for each such failure.

The Bidder, _____, certifies or affirms the truthfulness and accuracy of each statement of its certification and disclosure, if any. In addition, the Bidder understands and agrees that the provisions of 31 U.S.C. 3801, et seq. apply to this certification and disclosure, if any.

Executed this _____ day of _____, 2020

By _____
(Signature of authorized official)

(Title of authorized official)

INSTRUCTIONS FOR COMPLETION OF SF-LLL DISCLOSURE OF LOBBYING ACTIVITIES

This DISCLOSURE FORMS SHALL BE COMPLETED BY the reporting entity, whether Subawardee or prime Federal recipient, at the initiation or receipt of a covered Federal action, or a material change to a previous filing, pursuant to title 31 U.S.C. section 1352. The filing of a form is required for each payment or agreement to make payment to any lobbying entity for influencing or attempting to influence an officer or employee of any agency, a Member of Congress, an officer or employee of Congress, or an employee of a Member of Congress in connection with a covered Federal action. Use the SF-LLL-A Continuation Sheet for additional information if the space on the form is inadequate. Complete all items that apply for both the initial filing and material change report. Refer to the implementing guidance published by the Office of Management and Budget for additional information.

1. Identify the type of covered Federal action for which lobbying activity is and/or has been secured to influence the outcome of a covered Federal action.
2. Identify the status of the covered Federal action.
3. Identify the appropriate classification of this report. If this is a follow-up report caused by a material change to the information previously reported, enter the year and quarter in which the change occurred. Enter the date of the last previously submitted report by this reporting entity for this covered Federal action.
4. Enter the full name, address, city, state and zip code of the reporting entity. Include Congressional District, if known. Check the appropriate classification of the reporting entity that designates if it is, or expects to be a prime or subaward recipient. Identify the tier of the subawardee e.g., the first subawardee of the prime is the first tier. Subawards include but are not limited to subcontracts, subgrants and contract awards under grants.
5. If the organization filing the report in item 4 checks "Subawardee" then enter the full name, address city, state, and zip code of the prime Federal recipient. Include Congressional District.
6. Enter the name of the Federal agency making the award or loan commitment. Include at least one organizational level below agency, name if known. For example, Department of Transportation, United State Coast Guard.
7. Enter the Federal program name for description of the covered Federal action (item 1). If known, enter the full Catalog of Federal Domestic Assistance (CFDA) number for grants, cooperative agreements, loans, and loan commitments.
8. Enter the most appropriate Federal identifying number available for the Federal action identified in item 1 (e.g. Request for Proposal (RFP) number, Invitation for Bid (IFB) number, grant announcement number, the contract, grant, or loan award number, the application/proposal control number assigned by the Federal agency). Include prefixes, e.g., "RFP DE-90-001."
9. For a covered Federal action where there has been an award or loan commitment by the Federal agency, enter the Federal amount of the award/loan commitment for the prime entity identified in item 4 or 5.
10. (a) Enter the full name, address, city, state, and zip code of the lobbying entity engaged by the reporting entity identified in item 4 to influence the covered Federal action.
11. (b) Enter the full names of the individual(s) performing services, and include full address if different from 10 (a.). Enter Last Name, First Name, and Middle Initial (MI).
12. Enter the amount of compensation paid or reasonably expected to be paid by the reporting entity (item 4) to the lobbying entity (item 10). Indicate whether the payment has been made (actual) or will be made (planned). Check all boxes that apply. If this is a material change report, enter the cumulative amount of payment made or planned to be made.
13. Check the appropriate box (es). Check all boxes that apply. If payment is made through an in-kind contribution, specify the nature and value of the in-kind payment.
14. Check the appropriate box (es). Check all boxes that apply. If other, specify nature.
15. Provide a specific and detailed description of the services that the lobbyist has performed, or will be expected to perform, and the date(s) of any services rendered. Include all preparatory and related activity, not just time spent in actual contact with Federal officials. Identify the Federal official(s) or employee(s) contacted or the officer(s), employee(s), or Member(s) of Congress that were contacted.
16. Check whether or not a SF-LLL-A Continuation Sheet(s) is attached.
17. The certifying official shall sign and date the form, print his/her name, title, and telephone number.

Public reporting burden for this collection of information is estimated to average 30 minutes per response, including time for reviewing instructions, searching existing data sources, gathering and maintaining the data needed, and completing and reviewing the collection of information. Send comments regarding the burden estimate or any other aspect of this collection of information, including suggestions for reducing the burden, to the Office of Management and Budget Paperwork Reduction Project (0348-0446), Washington, D.C. 20503.

Approved by
OMB
003480045

DISCLOSURE OF LOBBYING ACTIVITIES CONTINUATION SHEET

Reporting Entity: _____ Page _____ of _____

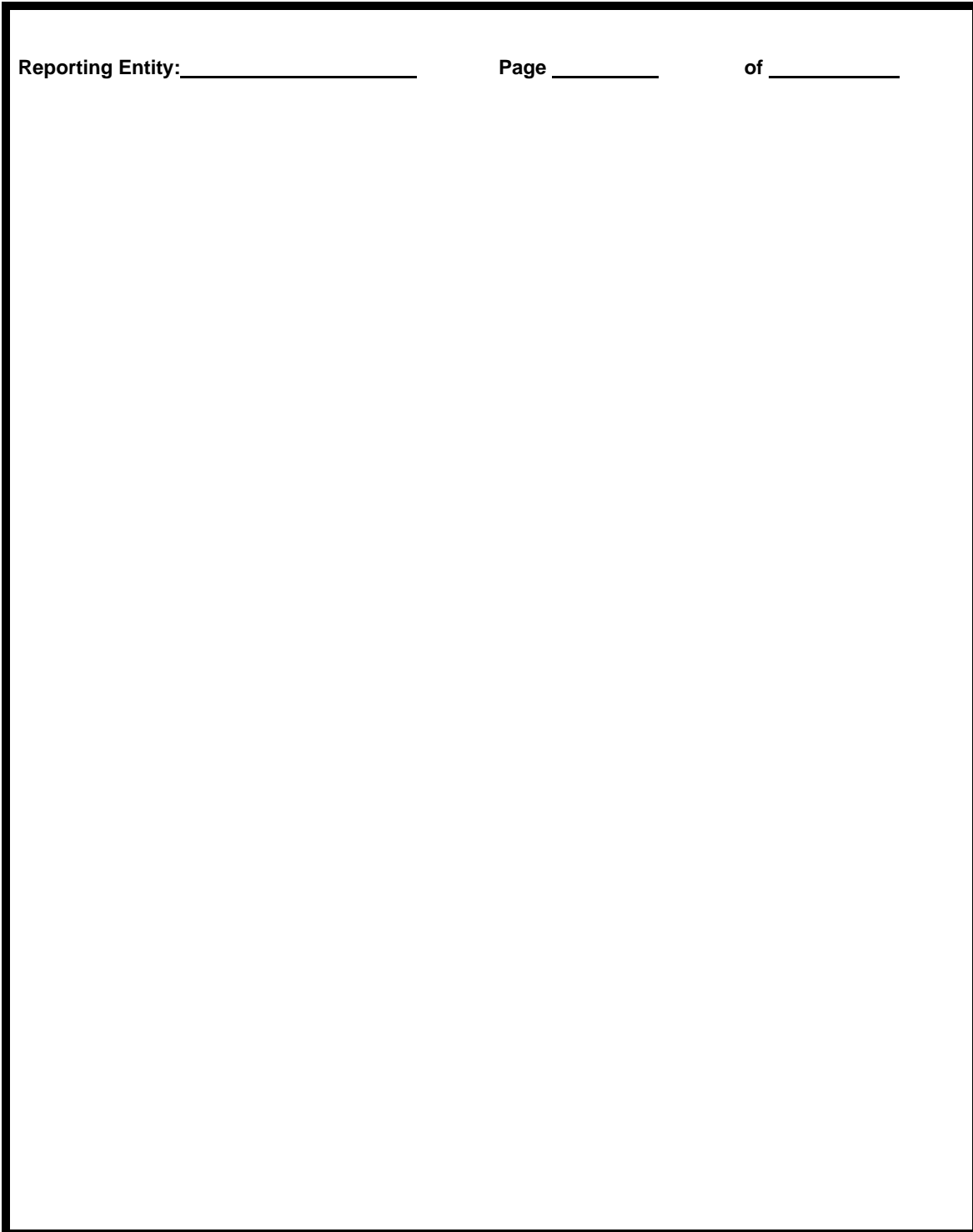

Authorized for Local Reproduction